

**DIRECT SUPPORT AND
GENERAL SUPPORT
MAINTENANCE MANUAL

FOR
HULL SYSTEMS
AND
COMPONENTS**

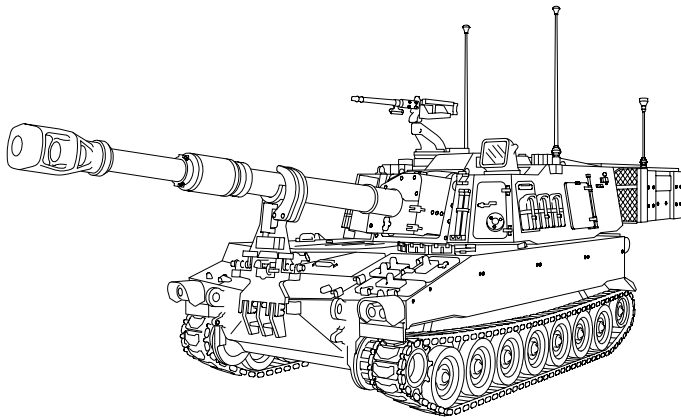

**HOWITZER, MEDIUM, SELF-PROPELLED:
155MM, M109A6
(NSN 2350-01-305-0028)
(EIC:3FC)**

Distribution Statement A: Approved for public release; distribution is unlimited.

© 1997 United Defense, L.P. All rights reserved under the copyright laws.

This material may be reproduced for U.S. Government purposes only, pursuant to the copyright license under the clause at (DFARS 52.227-7013) dated October 1988.

INTRODUCTION	1-1	
GENERAL MAINTENANCE	2-1	
TROUBLESHOOTING	3-1	
POWERPACK	4-1	
FUEL SYSTEM	5-1	
COOLING SYSTEM	6-1	
ELECTRICAL SYSTEMS	7-1	
WHEELS AND TRACKS	8-1	
STEERING	9-1	
BODY, CAB, HOOD, AND HULL	10-1	
BILGE PUMP	11-1	
SPECIAL PURPOSE KITS	12-1	
TOWING ATTACHMENTS	13-1	
ALPHABETICAL INDEX	INDEX-1	
ELECTRICAL SCHEMATICS	FP-1	

CHANGE
NO. 2

TM 9-2350-314-34-1
C2
HEADQUARTERS
DEPARTMENT OF THE ARMY
WASHINGTON, D.C., 1 AUGUST 2003

**TECHNICAL MANUAL
DIRECT SUPPORT AND GENERAL SUPPORT
MAINTENANCE MANUAL
FOR
HULL SYSTEMS AND COMPONENTS
HOWITZER, MEDIUM,
SELF-PROPELLED: 155MM M109A6
(NSN 2350-01-305-0028) (EIC: 3FC)**

TM 9-2350-314-34-1, 8 February 1999, is changed as follows:

1. The purpose of this change is to update TM 9-2350-314-34-1.
2. New or changed material is indicated by a vertical bar in the outside margin of text changes and by a hand symbol beside illustration changes.
3. Remove the old page and insert the new page as indicated below:

Remove Pages

a through d
A/(B blank)
4-15 and 4-16
6-3 through 6-6
7-33 and 7-34
7-40.9 and 7-40.10
7-41 through 7-46
none
10-1 and 10-2
10-11 and 10-12
B-1 through B-3/(B-4 blank)
E-3/(E-4 blank)
F-1 and F-2
Index-1 and Index-2
FP-7/(FP-8 blank)
Cover/Blank

Insert Pages

a through d
A and B
4-15 and 4-16
6-3 through 6-6
7-33 and 7-34
7-40.9 and 7-40.10
7-41 through 7-46
7-46.1/(7-46.2 blank)
10-1 and 10-2
10-11 and 10-12
B-1 through B-3/(B-4 blank)
E-3/(E-4 blank)
F-1 and F-2
Index-1 and Index-2
FP-7/(FP-8 blank)
Cover/Blank

4. File this change in front of the publication.

Distribution Statement A: Approved for public release; distribution is unlimited.

By Order of the Secretary of the Army:

Official:



JOEL B. HUDSON

*Administrative Assistant to the
Secretary of the Army*

0211907

PETER J. SCHOOMAKER
*General, United States Army
Chief of Staff*

DISTRIBUTION: To be distributed in accordance with the initial distribution number (IDN) 371935, requirements for TM 9-2350-314-34-1.

CHANGE
NO.1

TM 9-2350-314-34-1
C1
HEADQUARTERS
DEPARTMENT OF THE ARMY
WASHINGTON, D.C., 1 MAY 2001

**TECHNICAL MANUAL
DIRECT SUPPORT AND GENERAL SUPPORT
MAINTENANCE MANUAL
FOR
HULL SYSTEMS AND COMPONENTS
HOWITZER, MEDIUM,
SELF-PROPELLED: 155MM M109A6
(NSN 2350-01-305-0028) (EIC: 3FC)**

TM 9-2350-314-34-1, 8 February 1999, is changed as follows:

1. The purpose of this change is to update TM 9-2350-314-34-1.
2. New or changed material is indicated by a vertical bar in the outside margin of text changes and by a hand symbol beside illustration changes.
3. Remove the old page and insert the new page as indicated below:

Remove Pages

none
i and ii
1-3 and 1-4
3-3 through 3-22
7-1 and 7-2
7-23 through 7-40

10-3 and 10-4
10-7 and 10-8
F-1 and F-2
Index-1 and Index-2
DA2028-2 form-Sample
DA2028-2 form (4)
FP-1/(FP-2 blank) through
FP-9/(FP-10 blank)
Cover/Blank

Insert Pages

A/(B blank)
i and ii
1-3 and 1-4
3-3 through 3-22.20
7-1 and 7-2
7-23 through 7-40.15/
(7-40.16 blank)

10-3 and 10-4
10-7 and 10-8
F-1 and F-2
Index-1 and Index-2
DA2028-2 form-Sample
DA2028-2 form (4)
FP-1/(FP-2 blank) through
FP-11/(FP-12 blank)
Cover/Blank

4. File this change in front of the publication.

Distribution Statement A: Approved for public release; distribution is unlimited.

By Order of the Secretary of the Army:

Official:



JOEL B. HUDSON

*Administrative Assistant to the
Secretary of the Army*

0105102

ERIC K. SHINSEKI
*General, United States Army
Chief of Staff*

DISTRIBUTION: To be distributed in accordance with the initial distribution requirements for IDN: 371935
TM 9-2350-314-34-1.

WARNING

RADIOACTIVE MATERIAL(S)

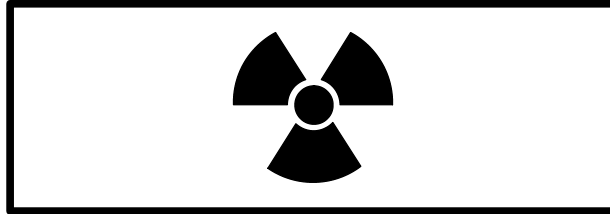

TRITIUM (HYDROGEN-3) GAS

This item contains radioactive material. Control of this radioactive material is mandated by federal law. Immediately report any suspected lost or damaged items to your Radiation Safety Officer (RSO). If your RSO cannot be reached, contact the TACOM-RI safety office.

Handle with care. In the event the radioluminous source is broken, cracked, or there is no illumination, immediately wrap device in plastic bag (item 5, Appendix D) and notify the local RSO. Contact the base safety office for the name and telephone number of your local RSO:

LOCAL RSO: _____ TELEPHONE: _____

SAFETY PROCEDURES FOR NUCLEAR REGULATORY COMMISSION (NRC) TRITIUM FIRE CONTROL DEVICES

1. Purpose: To implement mandatory license requirements for use and maintenance of tritium radioluminous fire control devices used on howitzers, mortars, tanks, and rifles.
2. Scope: This procedure is applicable to all personnel working with tritium devices, including unit, direct support, general support maintenance; and operator's levels.
3. Radiological hazard: The beta radiation emitted by tritium presents no external radiation hazard. However, if taken internally, it can damage soft tissue. If a capsule is broken, the tritium gas will dissipate into the surrounding air and surfaces near the vicinity of the break may become contaminated. Tritium can be taken into the body by inhalation, ingestion, or skin absorption/injection.
4. Safety precautions.
 - a. Check for illumination prior to use or service in low light or darkroom. If not illuminated, do not repair. Wrap the entire device in plastic bag (item 4, Appx B) and notify the local RSO.
 - b. No eating, drinking, or smoking will be allowed in tritium device work areas.
5. Emergency procedures: If a tritium source breaks, inform other personnel to vacate the area or move upwind. If skin contact is made with any area contaminated with tritium, wash immediately with nonabrasive soap and water. Report the incident to the local RSO. Actions below will be taken under supervision or direction of the local RSO.

- a. Personnel handling the device should wear rubber or latex gloves (item 11, Appx B). Device must be immediately double wrapped in plastic bag (item 4, Appx B), sealed (item 31, Appx B), and marked as "Broken Tritium Device — Do Not Open" per RSO direction. Dispose of used gloves as radioactive waste, per instructions from local RSO and wash hands well.
- b. Personnel who may have handled the broken tritium should report to health clinic for tritium bioassay. Optimum bioassay sample is at least 4 hours after exposure.
- c. Broken tritium sources indoors may result in tritium contamination in the area, such as work bench or table. The area must be cordoned off, restricted until wipe tests indicate no contamination.

6. Further information.

- a. Requirements for safe handling and maintenance are located in TM 9-254, General Maintenance Procedures for Fire Control Materiel.
- b. If assistance is needed, contact your local or major command (MACOM) safety office(s) for information on safe handling, shipping, storage, maintenance, or disposal of radioactive devices.
- c. The TACOM-RI RSO/licensee may be contacted by calling: DSN 793-2965/2969/2995, Commercial (309) 782-2965/2969/2995. After duty hours contact the Staff Duty Office through the operator at DSN 793-6001, Commercial (309) 782-6001. The following rules and regulations are available from TACOM-RI, ATTN: AMSTA-LC-SF, 1 Rock Island Arsenal, Rock Island, IL 61299-7630. Copies may be requested, or further information obtained by contacting the TACOM Radiation Safety Office (RSO).
 - (1) Title 10 CFR Part 19 - Notices, Instructions, and Reports to Workers.
 - (2) Title 10 CFR Part 20 - Standards for Protection Against Radiation.
 - (3) Title 10 CFR Part 21 - Reporting of Defects and Noncompliance.
 - (4) NRC License, License Conditions, and License Application.

7. Safety, Care, and Handling

WARNING

Nuclear, Biological, and Chemical (NBC) agents can kill you. If NBC exposure is suspected, all air filter media must be handled by personnel wearing full NBC protective equipment (FM 21-11).

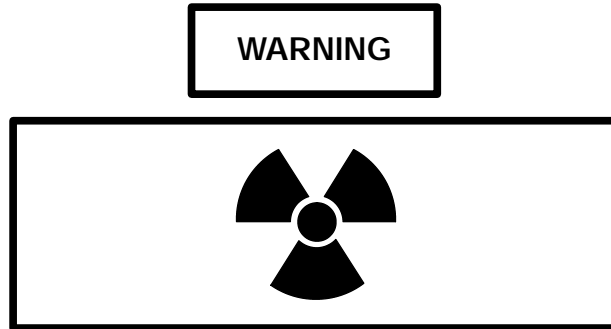

RADIATION HAZARD

Fire control instruments containing Tritium are used as a part of a backup system for manual firing. Loss of illumination may indicate that leakage has occurred. Do not attempt to repair a non-illuminated device.

Pre-Maintenance Check:

- a. Prior to taking any maintenance action on fire control devices (e.g., purging or charging M1A1 Collimator), check for broken/cracked reticle or loss of illumination as follows:
 - (1) Place device in the dark for at least four hours to prevent exterior light from activating the phosphor.
 - (2) Check for cracks/illumination in a low light environment after allowing sufficient time to accustom eyes to the dark.
- b. If illumination is not observed, or illuminated but cracks are observed, take following actions:
 - (1) Personnel handling the device should wear rubber or plastic gloves (item 11, Appx B).
 - (2) Seal entire device in two plastic bags (item 4, Appx B).
 - (3) Mark the outer bag as "Broken tritium device - do not open."
 - (4) Dispose of used gloves as radioactive waste as per instructions from local Radiation Safety Officer (RSO). Wash well with nonabrasive soap and water.
- c. If illumination is observed, maintenance actions may proceed.



WARNING

CARBON MONOXIDE POISONING IS DEADLY

Carbon monoxide is a colorless, odorless, deadly poisonous gas, which, when breathed, deprives the body of oxygen and causes suffocation. Exposure to carbon monoxide produces headache, dizziness, loss of muscular control, drowsiness, and coma. Permanent brain damage or death can result from severe exposure.

Carbon monoxide occurs in the exhaust of fuel-burning heaters and internal-combustion engines and becomes dangerously concentrated under conditions of inadequate ventilation. The following precautions must be observed to ensure the safety of personnel whenever the personnel heater, main, or auxiliary engine of any vehicle is operated for maintenance purposes or tactical use.

**THE BEST DEFENSE AGAINST CARBON MONOXIDE
POISONING IS ADEQUATE VENTILATION**

1. DO NOT operate heater or engine of vehicle in an enclosed area unless it is ADEQUATELY VENTILATED.
2. DO NOT idle engine for long periods without maintaining adequate ventilation in personnel compartments.
3. DO NOT drive any vehicle with inspection plates, cover plates, or engine compartment doors removed unless necessary for maintenance purposes.
4. BE ALERT at all times during vehicle operation for exhaust odors and exposure symptoms. If either are present, IMMEDIATELY VENTILATE personnel compartments. If symptoms persist, remove affected personnel from vehicle and treat as follows: Expose to fresh air; keep warm; do not permit physical exercise; if necessary, administer artificial respiration. For detailed first aid instruction, consult FM 21-11, First Aid for Soldiers.

WARNING**EXHAUST SYSTEM HAZARDS**
EXHAUST GASES CAN KILL

Brain damage or death can result from heavy exposure. Precautions must be followed to ensure crew safety when personnel heater, main, or auxiliary engine of any vehicle is operated for any purpose.

1. Do not operate vehicle engine in enclosed areas.
2. Do not idle vehicle engine with vehicle windows closed.
3. Be alert at all times for exhaust odors.
4. Be alert for exhaust poisoning symptoms. They are:
 - Headache
 - Dizziness
 - Sleepiness
 - Loss of muscular control
5. If you see another person with exhaust poisoning symptoms:
 - Remove person from area
 - Expose to open air
 - Keep person warm
 - Do not permit physical exercise
 - Administer artificial respiration, if necessary*
 - Seek immediate medical attention
6. BE AWARE, the field protective mask for nuclear-biological-chemical (NBC) protection will not protect you from carbon monoxide poisoning.

*For artificial respiration, refer to FM 21-11.

- THE BEST DEFENSE AGAINST EXHAUST POISONING IS ADEQUATE VENTILATION.
- Allow engine to cool before performing maintenance on the muffler, exhaust pipe, exhaust manifold, or turbocharger. If necessary, use insulated pads and gloves.
 - Do not touch hot exhaust system with bare hands; injury to personnel will result.

WARNING

ENGINE OIL HAZARD

Do not drain engine oil while engine is hot. Severe injury to personnel may result.

WARNING

NOISE HAZARDS

- Excessive noise levels are present any time the equipment is operating. Wear hearing protection while operating or working around equipment while it is running. Failure to do so could result in damage to your hearing. Seek medical aid should you suspect a hearing problem (ref. FM 21-11).
- Hearing protection is required for operator and also for personnel working in and around this vehicle while engine is running.
- Personnel hearing can be PERMANENTLY DAMAGED if exposed to constant high noise levels of 85 dB (A) or greater. Wear approved hearing protection devices when working in high noise level areas. Personnel exposed to high noise levels shall participate in a hearing conservation program in accordance with TB MED 501. Hearing loss occurs gradually but becomes permanent over time.

WARNING

FALLING EQUIPMENT HAZARDS

- Never crawl under equipment when performing maintenance unless equipment is securely blocked. Equipment may fall and cause serious injury or death to personnel.
- Keep clear of equipment when it is being raised or lowered. Equipment may fall and cause serious injury or death to personnel.
- Do not work on any item supported only by lift jacks or hoist. Always use blocks or proper stands to support the item prior to any work. Equipment may fall and cause serious injury or death to personnel.
- Do not allow heavy components to swing while suspended by lifting device. Equipment may strike personnel and cause injury.
- Exercise extreme caution when working near a cable under tension. A snapped cable, shifting or swinging load may result in injury or death to personnel.
- All personnel must stand clear during lifting operations. A swinging or shifting load may cause injury or death to personnel.

WARNING**FIRE HAZARD**

Diesel fuel and combustible materials are used in operation and maintenance of this equipment. Do not smoke or allow open flames or sparks in areas where diesel fuel and combustible materials are used or stored. DEATH or severe injury may result if personnel fail to observe this precaution. If you are burned, seek medical aid immediately (ref. FM 21-11).

WARNING**STEAM UNDER PRESSURE**

- Do not remove the radiator cap when the engine is hot; steam and hot coolant can escape and burn personnel.
- Use extreme care when removing the radiator pressure cap. Sudden release of pressure can cause a steam flash which could seriously injure personnel. Slowly loosen cap to the first stop to relieve pressure before removing cap completely. After use, securely tighten cap.
- Use a clean, thick waste cloth or like material to remove the cap. Avoid using gloves. If hot water soaks through gloves, personnel could be burned.
- Extreme care should be taken when removing radiator filler cap if temperature gage reads above 180° F (82° C). Contact by steam or hot coolant may result in injury or death to personnel.

WARNING**DO NOT USE MINERAL SPIRITS OR PAINT
THINNER TO CLEAN THE HOWITZER**

Mineral spirits, paint thinners are highly toxic and combustible. Prolonged breathing can cause dizziness, nausea, and even death (ref. FM 21-11).

DO NOT USE THESE MATERIALS

WARNING

DRY-CLEANING SOLVENT

Dry-cleaning solvent (P-D-680) used to clean parts, is toxic and flammable. Wear protective goggles and gloves and use only in a well-ventilated area. Avoid contact with skin, eyes, and clothes. Do not breathe vapors. Do not use near open flame or excessive heat. Do not smoke when using solvent. Failure to do so could cause SERIOUS INJURY. If you become dizzy while using cleaning solvent, get fresh air immediately, and if necessary, get medical attention. If contact with skin or clothes is made, flush thoroughly with water. If the solvent contacts your eyes, wash with water immediately, and obtain medical aid (ref. FM 21-11).

WARNING

BATTERY HAZARDS

- Batteries contain sulfuric acid which can cause severe burns. Avoid contact with skin, eyes, or clothing, and remove all metal or jewelry. If battery electrolyte is spilled, stop its burning effects immediately (ref. FM 21-11).
- Lead-acid battery gases can explode. Do not smoke, have open flames, or make sparks around a battery, especially if caps are off. If a battery is gassing, it can explode and cause injury to personnel.
 - a. Ventilate when charging or using in an enclosed space.
 - b. Wear safety goggles and acid-proof gloves when battery cover must be removed or when adding electrolyte.
 - c. Avoid electrolyte contact with skin, eyes, or clothing. If battery electrolyte spills, take immediate action to stop burning effects:
 - External: Immediately flush with cold running water to remove all acid.
 - Eyes: Flush with cold water for at least 15 minutes. Seek immediate medical attention.
 - Internal: Drink large amounts of water or milk. Follow with milk of magnesia, beaten egg, or vegetable oil. Seek immediate medical attention.
 - Clothing or Vehicle: Wash at once with cold water. Neutralize with baking soda or household ammonia solution.
- Wear safety glasses or goggles when checking batteries. Always check electrolyte level with engine stopped. Do not smoke or use exposed flame when checking battery; explosive gases are present and severe injury to personnel can result.
- Remove or disconnect batteries and turn vehicle MASTER switch OFF prior to performing maintenance in immediate battery area or working on electrical system. Such disconnections prevent electrical shock to personnel or equipment.

WARNING

BATTERY HAZARDS - CONTINUED

- Battery acid (electrolyte) is extremely harmful. Always wear safety goggles and rubber gloves, and do not smoke when performing maintenance on batteries. Injury will result if acid contacts skin or eyes. Wear rubber apron to prevent clothing being damaged.
- Remove all jewelry such as rings, dog tags, bracelets, etc. If jewelry contacts battery terminal, a direct short may result in instant heating of tools, damage to equipment, and injury or death to personnel.

WARNING

ELECTRICAL HAZARD

Be certain vehicle MASTER switch is OFF when working on hull electrical system to prevent injury due to electrical shock (ref. FM 21-11).

WARNING

NBC EXPOSURE AND VEHICLE AIR FILTER HAZARDS

- If Nuclear Biological Chemical (NBC) exposure is suspected, all air filter media must be handled by personnel wearing full NBC protective equipment (ref. FM 3-3) and proper handling and disposal procedures followed.
- NBC-contaminated air filters must be handled and disposed of only by authorized and trained personnel. The unit commander or senior officer in charge of maintenance personnel must ensure that prescribed protective clothing (FM 3-4) is used, and prescribed safety measures and decontamination procedures (FM 3-5) are followed. The local unit SOP is responsible for final disposal of contaminated air filters. Failure to comply may cause severe injury or death to personnel.
- The NBC protection filters use a type of carbon that contains Chromium VI. This is a known carcinogen if inhaled or swallowed. Damaged or unusable filters are classified as hazardous waste.
 - a. Do not throw away damaged or unusable filters as trash.
 - b. Turn in damaged or unusable filters to your Hazardous Waste Management Office or Defense Reutilization and Marketing Office (DRMO).

Filters are completely safe to handle and use if they are not damaged in such a way that carbon leaks from them. If carbon does leak, use protection such as a dust respirator to cover nose and mouth and put carbon in container such as a self-sealing plastic bag; turn in to Hazardous Waste Management Office or DRMO.

Disposal of hazardous waste is restricted by law. Violation is subject to criminal penalties.

WARNING

FIRE EXTINGUISHING SYSTEM HAZARDS

- Fire bottles can discharge and injure personnel. Insert antirecoil plugs, lock pins, and cotter pins before working on or near bottles.
- CO² can cause frostbite or eye injury. Wear protective clothing and goggles to avoid contact. If CO² contacts hands, hold hands under armpits or in warm water until warmed. If CO² contacts eyes, flush with large amounts of water and get medical attention immediately.

WARNING

FAN SCREEN HAZARD

Protective fan screens must be installed prior to performing maintenance in the engine compartment when engine is running or when running engine in the ground hop mode. High air flow can suck hands into fan impellers.

WARNING

ROTATION HAZARD

When working on a running engine, provide shielding for exposed rotating parts. Tools, clothing, or hands can get caught and cause serious injury to personnel.

WARNING

FALLING EQUIPMENT/ROLLING VEHICLE HAZARD

Unless otherwise specified, perform all maintenance procedures with all equipment lowered to the ground, transmission in neutral, parking/emergency brake applied, and the engine stopped to prevent possible injury to personnel due to falling equipment or rolling vehicle (ref. FM 21-11).

WARNING**PARKING HAZARD**

Do not park vehicles head to head. Personnel injury or damage to the vehicles could occur if one vehicle jumps (ref. FM 21-11).

WARNING**EXPLOSION HAZARD**

Cylinders containing compressed gases must not be dropped, struck, or subjected to any temperature above +140°F (+60°C). This could result in an explosion and injury to personnel (ref. FM 21-11).

WARNING**COMPRESSED AIR HAZARD**

Compressed air used for cleaning purposes will not exceed 30 psi (207 kPa). Use only with effective chip guarding and personal protective equipment (goggles/shield, gloves, etc.)

WARNING**SNAP AND RETAINING RING HAZARD**

Use care when removing snap and retaining rings. Snap and retaining rings are under spring tension and can act as projectiles when released and could cause severe eye injury.

WARNING**TURRET HAZARD**

The turret can kill or injure personnel as it turns. Do not enter or exit turret unless turret traverse lock is locked and turret power is off.

WARNING

FASTENERS AND ATTACHING HARDWARE HAZARD

Always use the same fastener part number (or equivalent) when replacing fasteners. Do not risk using a fastener of less quality; do not mix metric and inch (customary) fasteners. Mismatched or incorrect fasteners can result in damage, malfunction, or injury.

WARNING

ADHESIVE HAZARDS

- Adhesive causes immediate bonding on contact with eyes, skin, or clothing and also gives off harmful vapors. Wear protective goggles and use it in a well-ventilated area. If adhesive gets in eyes, try to keep eyes open; flush eyes with water for 15 minutes and get immediate medical attention.
- Sealing compound MIL-S-46163 can damage your eyes. Wear safety goggles/glasses when using; avoid contact with eyes. If sealant contacts eyes, flush eyes with water and get immediate medical attention.

WARNING

WASTE HAZARDS

When servicing this vehicle, performing maintenance, or disposing of materials such as engine coolant, transmission fluid, lubricants, battery acids or batteries, and CARC paint, consult your unit/local regulatory guidance. If further information is needed, please contact the U.S. Army Environmental Hotline at 1-800-872-3845.

INSERT LATEST CHANGED PAGES.
DESTROY SUPERSEDED PAGES

LIST OF EFFECTIVE PAGES

Note: The portion of the text affected by the changes is indicated by a vertical line in the outer margin of the page. Changes to illustrations are indicated by miniature pointing hands. Changes to wiring diagrams are indicated by shaded areas.

Date of issue for original and changed pages are:

Original 0 8 February, 1999
 Change 1 1 May 2001
 Change 2 1 August, 2003

TOTAL NUMBER OF PAGES IN THIS PUBLICATION IS 383, CONSISTING OF THE FOLLOWING:

Page No.	*Change No.	Page No.	*Change No.	Page No.	*Change No.
Cover	2	7-1	1	10-11 – 10-12	2
Blank	0	7-2	0	11-1 – 11-10	0
Change 2 Errata Added (2)	2	7-3 – 7-22	0	11-11	0
Change 1 Errata (2)	1	7-23	0	11-12 Blank	0
a – b	2	7-24	1	12-1 – 12-42	0
c	2	7-25 – 7-32	1	13-1 – 13-2	0
d	0	7-33	1	13-3	0
e – l	0	7-34	2	13-4 Blank	0
A	1	7-35 – 7-40	1	A-1 – A-2	0
B	1	7-40.1 – 7-40.8 Added	1	A-3	0
i – ii	1	7-40.9 Added	1	A-4 Blank	0
iii	0	7-40.10	2	B-1	0
iv Blank	0	7-40.11 – 7-40.14 Added	1	B-2	2
1-1 – 1-2	0	7-40.15 Added	1	B-3	2
1-3	1	7-40.16 Blank	1	B-4 Blank	0
1-4	0	7-41	2	C-1 – C-4	0
2-1 – 2-6	0	7-42	0	D-1 – D-4	0
3-1 – 3-2	0	7-43	2	D-5	0
3-3 – 3-21	1	7-44	0	D-6 Blank	0
3-22 Blank	1	7-45 – 7-46	2	E-1 – E-2	0
3-22.1 – 3-22.18 Added	1	7-46.1 Added	2	E-3	2
3-23 – 3-42	0	7-46.2 Blank Added	2	E-4 Blank	0
4-1 – 4-14	0	7-47 – 7-66	0	F-1 – F-2	2
4-15	2	8-1 – 8-6	0	F-3	0
4-16	0	8-7	0	F-4 Blank	0
4-17 – 4-34	0	8-8 Blank	0	G-1 – G-2	0
4-35	0	9-1 – 9-2	0	Index-1	1
4-36 Blank	0	9-3	0	Index-2	2
5-1 – 5-30	0	9-4 Blank	0	Index-3	0
6-1 – 6-2	0	10-1	2	Index-4 Blank	0
6-3	0	10-2	0	FP-1	1
6-4	2	10-3	0	FP-2 Blank	0
6-5	2	10-4	1	FP-3	1
6-6	0	10-5 – 10-6	0	FP-4 Blank	0
6-7 – 6-24	0	10-7	0	FP-5	1
6-25	0	10-8	1	FP-6 Blank	0
6-26 Blank	0	10-9 – 10-10	0	FP-7	2

*Zero in this column indicates an original page

TM 9-2350-314-34-1

Page No.	*Change No.	Page No.	*Change No.	Page No.	*Change No.
FP-8 Blank	0	Blank	0	DA Form 2028-2 Address ...	1
FP-9	1	DA Form 2028-2	1	DA Form 2028-2	1
FP-10 Blank	0	DA Form 2028-2 Address ...	1	DA Form 2028-2 Address ...	1
FP-11 Added	1	DA Form 2028-2	1	Measurement Page	0
FP-12 Blank	1	DA Form 2028-2 Address ...	1	Blank	0
DA Form 2028-2 Sample	1	DA Form 2028-2	1		

*Zero in this column indicates an original page

TECHNICAL MANUAL
No. 9-2350-314-34-1

HEADQUARTERS
DEPARTMENT OF THE ARMY
WASHINGTON, D.C. 8 FEBRUARY 1999

**DIRECT SUPPORT AND GENERAL SUPPORT
MAINTENANCE MANUAL FOR
HULL SYSTEMS AND COMPONENTS
HOWITZER, MEDIUM, SELF-PROPELLED:
155MM, M109A6
(NSN 2350-01-305-0028) (EIC: 3FC)**

REPORTING ERRORS AND RECOMMENDING IMPROVEMENTS

You can help improve this publication. If you find any mistakes or if you know of a way to improve the procedures, please let us know. Submit your DA Form 2028-2 (Recommended Changes to Equipment Technical Publications), through the Internet, on the Army Electronic Product Support (AEPS) website. The Internet address is <http://aeeps.ria.army.mil>. If you need a password, scroll down and click on "ACCESS REQUEST FORM". The DA Form 2028 is located in the ONLINE FORMS PROCESSING section of the AEPS. Fill out the form and click on SUBMIT. Using this form on the AEPS will enable us to respond quicker to your comments and better manage the DA Form 2028 program. You may also mail, fax or email your letter, DA Form 2028, or DA Form 2028-2 direct to: Technical Publication Information Office, TACOM-RI, 1 Rock Island Arsenal, Rock Island, IL 61299-7630. The email address is TACOM-TECH-PUBS@ria.army.mil. The fax number is DSN 793-0726 or Commercial (309) 782-0726.

Distribution Statement A: Approved for public release; distribution is unlimited.

TABLE OF CONTENTS

<u>CONTENTS</u>	<u>PAGE</u>
HOW TO USE THIS MANUAL.	iii
CHAPTER 1 - INTRODUCTION	1-1
Section I. General Information	1-2
Section II. Equipment Description and Data	1-4
Section III. Principles of Operation	1-4
CHAPTER 2 - GENERAL MAINTENANCE	2-1
Section I. Repair Parts, Special Tools, TMDE, and Support Equipment	2-2
Section II. General Hull Maintenance Instructions	2-2
Section III. Cleaning, Painting, and Lubrication	2-6
CHAPTER 3 - TROUBLESHOOTING	3-1
CHAPTER 4 - POWERPACK	4-1
Section I. Powerpack	4-2
Section II. Engine Assembly	4-13
Section III. Preparation for Storage or Shipment	4-17
Section IV. Transmission Trunnion Caps	4-21
Section V. Final Drive Assembly	4-25

*This manual supersedes TM 9-2350-314-34-1 dated 25 October 1993, including all changes.

TABLE OF CONTENTS - CONTINUED

<u>CONTENTS</u>	<u>PAGE</u>
CHAPTER 5 - FUEL SYSTEM	5-1
Section I. Air Cleaner	5-2
Section II. Tanks, Lines, Fittings, and Headers	5-9
CHAPTER 6 - COOLING SYSTEM	6-1
CHAPTER 7 - ELECTRICAL SYSTEMS	7-1
Section I. Generator	7-2
Section II. Instrument or Engine Control Panels	7-6
Section III. Hull Wiring Harness	7-41
Section IV. Ventilating Equipment	7-56
CHAPTER 8 - WHEELS AND TRACKS	8-1
Section I. Suspension Assembly	8-2
Section II. Track Idlers and Brackets	8-4
CHAPTER 9 - STEERING	9-1
CHAPTER 10 - BODY, CAB, HOOD, AND HULL	10-1
Section I. Body, Cab, Hood, and Hull Assemblies	10-2
Section II. Driver's Hatch and Periscopes	10-11
CHAPTER 11 - BILGE PUMP	11-1
CHAPTER 12 - SPECIAL PURPOSE KITS	12-1
Section I. Winterization Kit Installation	12-2
Section II. Winterization Kit Components	12-19
Section III. Ventilation Kit Installation	12-41
CHAPTER 13 - TOWING ATTACHMENTS	13-1
APPENDIX A - REFERENCES	A-1
APPENDIX B - EXPENDABLE AND DURABLE ITEMS LIST	B-1
APPENDIX C - ILLUSTRATED LIST OF MANUFACTURED ITEMS	C-1
APPENDIX D - TORQUE LIMITS	D-1
APPENDIX E - MANDATORY REPLACEMENT PARTS LIST	E-1
APPENDIX F - TOOL IDENTIFICATION LIST	F-1
APPENDIX G - CORROSION PREVENTION AND CONTROL	G-1
ALPHABETICAL INDEX	INDEX-1
HULL ELECTRICAL SCHEMATICS	FP-1

HOW TO USE THIS MANUAL

Indexing

Five major indexing procedures are used in this manual to help the technician locate information rapidly.

1. Cover index: Lists sections of text and page number. Includes Index Mark which lines up with Index Marks on the actual page of reference.
2. Table of Contents: pages i through ii.
3. Chapter indexes: Listing information covered within the chapter and section.
4. Troubleshooting symptoms: Identifies system malfunction and provides page reference for specific troubleshooting procedures.
5. Index, page INDEX-1 through INDEX-3: Alphabetical listing of information.

Maintenance Text and Illustrations (Chapter 4 through 13)

1. Maintenance procedures are to be performed in the sequence shown in the text and illustrations. Step 1 must be performed before Step 2. Procedure a must be performed before Procedure b, and so on.
2. Equipment illustrations use numbers to identify parts of the system/components.

Example:

1. Remove both wiring harnesses (1) and (2).
2. Remove four screws (3), four flat washers (4), four lockwashers (5), and four nuts (6).

CHAPTER 1

INTRODUCTION

GENERAL

This chapter provides a general introduction to the M109A6 Howitzer. Section I describes procedures for destroying equipment to prevent enemy use, references to other technical manuals, and forms to recommend improvements. Sections II and III reference the mechanic to equipment description and data and operating principles of the M109A6 Howitzer's systems.

<u>CONTENTS</u>	<u>Page</u>
Section I. GENERAL INFORMATION	
1-1 SCOPE	1-2
1-2 MAINTENANCE FORMS, RECORDS, AND REPORTS	1-2
1-3 DESTRUCTION OF ARMY MATERIEL TO PREVENT ENEMY USE	1-2
1-4 PREPARATION FOR STORAGE OR SHIPMENT	1-3
1-5 QUALITY ASSURANCE (QA)	1-3
1-6 NOMENCLATURE CROSS-REFERENCE LIST	1-3
1-7 REPORTING EQUIPMENT IMPROVEMENT RECOMMENDATIONS	1-3
1-8 WARRANTY INFORMATION	1-3
1-9 CORROSION PREVENTION AND CONTROL	1-3
Section II. EQUIPMENT DESCRIPTION AND DATA	
1-10 EQUIPMENT CHARACTERISTICS, CAPABILITIES, AND FEATURES	1-4
1-11 LOCATION AND DESCRIPTION OF MAJOR COMPONENTS	1-4
1-12 DIFFERENCES BETWEEN MODELS	1-4
1-13 EQUIPMENT DATA	1-4
Section III. PRINCIPLES OF OPERATION	
1-14 EQUIPMENT OPERATION AND DESCRIPTION	1-4

Section I. GENERAL INFORMATION

1-1 SCOPE.

Type of manual: Direct Support and General Support Maintenance. This manual deals with maintenance for the hull and associated components. Chapters 4 through 13 contain Direct Support Maintenance. TM 9-2350-314-34-2 deals with maintenance of the cab and associated components.

Model number and equipment name: M109A6, Howitzer, Medium, Self-Propelled, 155MM.

Purpose of Equipment: Provides artillery fire in support of ground-gaining troops.

1-2 MAINTENANCE FORMS, RECORDS, AND REPORTS.

Department of the Army forms and procedures used for equipment maintenance will be those prescribed by DA PAM 738-750, The Army Maintenance Management System (TAMMS) as contained in Maintenance Management Update.

Accidents involving injury to personnel or damage to materiel will be reported on DA Form 285 (Accident Reporting) in accordance with AR 385-40.

1-3 DESTRUCTION OF ARMY MATERIEL TO PREVENT ENEMY USE.

Refer to TM 750-244-6 for procedures on how to destroy the M109A6 Howitzer. You will find procedures for destruction of munitions in TM 750-244-5-1 (conventional ammo) or TM 43-0002-33 (improved conventional munitions). Procedures for destruction of chemical munitions are outlined in TM 3-250.

Below are some general guidelines to follow in destruction of equipment to prevent enemy use.

Destruction of the vehicle, armament, and equipment, when subject to capture or abandonment in a combat zone, will be undertaken only when the unit commander decides such action is necessary in accordance with orders of, or policy established by, the Army commander.

In general, destruction of essential parts, followed by burning, will usually be sufficient to render the vehicle, armament, and equipment useless. Time is usually critical.

Materiel must be damaged so that it cannot be restored to usable condition by either repair or cannibalization. If lack of time or personnel prevents destruction of all parts, give priority to destruction of parts hardest to replace. It is important that the same parts be destroyed on all units to prevent construction of one complete unit from several damaged ones.

All items of sighting and fire control instruments and equipment, especially telescopes, gunner's quadrants, and binoculars, are costly and difficult to replace. They should be conserved whenever possible. If you cannot carry them with you, destroy them by smashing with your sledgehammer, pick or mattock. Throw the pieces in all directions.

When time is short, a method of destroying the equipment with materials at hand is as follows:

Retrieve or smash sighting and fire control equipment.

Load cannon with projectile and full powder charge. Attach a 50-foot (15.2 m) or longer lanyard to firing mechanism. Disconnect recoil cylinder lines and fire the weapon.

Take a sledgehammer and bend the end of the counterrecoil buffer rod.

A second method is to close the breechblock and toss several thermite grenades down the tube. Elevate the tube so that the grenades will fall against the breechblock. This will melt the breech and the powder chamber, causing them to fuse together.

1-4 PREPARATION FOR STORAGE OR SHIPMENT.

Refer to TM 9-2350-314-20-1 for the requirements for Administrative Storage. Refer to TM 9-2350-314-20-2 for the requirements for vehicle shipment.

1-5 QUALITY ASSURANCE (QA).

No particular quality assurance manual pertains specifically to the M109A6 Howitzer.

Defective material received through the supply system should be reported on Quality Deficiency Report (QDR) SF368. Instructions for preparing QDRs are provided in AR 702-7, Reporting of Quality Deficiency Data. QDRs should be mailed directly to:

Commander
U.S. Army Tank-automotive & Armaments Command
ATTN: AMSTA-TR-E/PQDR
Warren, MI 48397-5000

A reply will be furnished directly to you.

1-6 NOMENCLATURE CROSS-REFERENCE LIST.

Nomenclature in this manual was chosen in accordance with the terms used for provisioning as they appear in the Repair Parts and Special Tools List (RPSTL) and Maintenance Allocation Chart (MAC).

A few tools and hull components are, however, referred to by names more common than those in the RPSTL. In many cases the more common name is a shorter name for the same component.

OFFICIAL PROVISIONING NOMENCLATURE

155MM Medium Self-Propelled Howitzer M109A6

Cable

Cable assembly

Centrifugal Fan

Gasket (Gear Box)

Nonelectrical wire

Radio Filter

MORE COMMON NAME

Howitzer

Wire

Wiring harness

Blower Motor Wheel (Winterization Kit, Heater Blower)

Retainer Plate

Lockwire

Noise Filter

1-7 REPORTING EQUIPMENT IMPROVEMENT RECOMMENDATIONS.

If your M109A6 Howitzer needs improvement, let us know. Send us an Equipment Improvement Recommendation (EIR). You, the user, are the only one who can tell us what you don't like about our equipment. Let us know why you don't like the design or performance. Put it on a SF368 (Product Quality Deficiency Report). EIR's should be mailed to:

Department of the Army
U.S. Army Tank-automotive and Armaments Command
ATTN: AMSTA-LC-CIP-W
Rock Island, IL 61299-7630

1-8 WARRANTY INFORMATION.

There is no special warranty provision for M109A6 vehicles.

1-9 CORROSION PREVENTION AND CONTROL.

Corrosion Prevention Control (CPC) of Army materiel is a continuing concern. It is important that any corrosion problem with the self-propelled howitzer be reported so that improvements can be made to prevent the problem in the future. While corrosion is typically associated with rusting of metals, it can also include deterioration of other materials such as rubber and plastic. Unusual cracking, softening, swelling, or breaking of these materials may be a corrosion problem. Additional information concerning corrosion, prevention and control is found in Appendix G of this manual. If a corrosion problem is identified, report the specific problem to the address specified in Appendix G.

Section II. EQUIPMENT DESCRIPTION AND DATA

1-10 EQUIPMENT CHARACTERISTICS, CAPABILITIES, AND FEATURES.

1-10.1 Characteristics.

Refer to TM 9-2350-314-10 for Characteristics of the M109A6 Howitzer.

1-10.2 Capabilities and Features.

Refer to TM 9-2350-314-10 for Capabilities and Features of the M109A6 Howitzer.

1-11 LOCATION AND DESCRIPTION OF MAJOR COMPONENTS.

Refer to TM 9-2350-314-10 for Location and Description of Major Components of the M109A6 Howitzer.

1-12 DIFFERENCES BETWEEN MODELS.

There is currently only one model of the M109A6 Howitzer.

1-13 EQUIPMENT DATA.

Refer to TM 9-2350-314-10, TM 9-2350-314-20-1 and TM 9-2350-314-20-2 for equipment relative to the M109A6 Howitzer.

Section III. PRINCIPLES OF OPERATION

1-14 EQUIPMENT OPERATION AND DESCRIPTION.

Refer to TM 9-2350-314-10 and TM 9-2350-314-20-1 for hull-related systems and components. Cab-related systems and components are found in TM 9-2350-314-20-2 and TM 9-2350-314-34-2.

CHAPTER 2 GENERAL MAINTENANCE

GENERAL

This chapter provides general maintenance instructions and basic guidance for performing required maintenance functions. References are also provided for maintenance-related procedures not within the scope of this manual (e.g., welding).

<u>CONTENTS</u>	<u>Page</u>
Section I. REPAIR PARTS, SPECIAL TOOLS, TMDE, AND SUPPORT EQUIPMENT	
2-1 GENERAL	2-2
2-2 COMMON TOOLS AND EQUIPMENT	2-2
2-3 SPECIAL TOOLS AND SUPPORT EQUIPMENT	2-2
2-4 REPAIR PARTS	2-2
Section II. GENERAL HULL MAINTENANCE INSTRUCTIONS	
2-5 DISASSEMBLY AND ASSEMBLY PROCEDURES	2-2
2-6 REPLACEMENT OF PARTS	2-3
2-7 BALL AND ROLLER BEARINGS	2-3
2-8 REMOVING BURRS, SCRATCHES, AND RAISED METAL	2-4
2-9 SCREW THREAD INSERTS (ONE PIECE TYPE)	2-4
2-10 WELDING	2-6
2-11 ELECTRICAL TEST EQUIPMENT AND ELECTRICAL TESTING	2-6
2-12 SHAFTS, GEARS, AND BEARINGS	2-6
Section III. CLEANING, PAINTING, AND LUBRICATION	
2-13 CLEANING	2-6
2-14 PAINTING	2-6
2-15 LUBRICATION	2-6

Section I. REPAIR PARTS, SPECIAL TOOLS, TMDE, AND SUPPORT EQUIPMENT

2-1 GENERAL.

Repair parts, special tools, test measurement and diagnostic equipment (TMDE) and support equipment are issued for maintaining the vehicle. Tools and equipment should not be used for purposes other than those prescribed. When not in use, they should be properly stowed.

2-2 COMMON TOOLS AND EQUIPMENT.

For authorized common tools and equipment, refer to the Modified Table of Organization and Equipment (MTOE), CTA 50-970, or CTA 8-100, as applicable to your unit.

The tool kit (box) assigned to the mechanic (on a 1-per-mechanic-by-MOS basis) shall be identified in the individual maintenance paragraphs by nomenclature and supply catalog (SC) number. No tool in the kit shall be further identified. Other tools required for performance of all tasks for the maintenance levels covered in the manual shall be identified in the setup and shall be referenced to the Tool Identification List, Appendix F "Other tools" includes tools which are part of components of shop sets authorized to sections/teams; special tools authorized by RPSTL; fabricated tools; and items of TMDE.

2-3 SPECIAL TOOLS AND SUPPORT EQUIPMENT.

The special tools and support equipment listed and illustrated in TM 9-2350-314-24P-1 are the only special tools and equipment necessary to perform maintenance operations described in this manual. TM 9-2350-314-24P-1 is the authority for requisitioning special tools and equipment for supporting maintenance use. All special tools required in this technical manual are listed in Appendix F of this manual. Fabricated tools are listed in Appendix C of this manual.

2-4 REPAIR PARTS.

Repair parts are listed and illustrated in the repair parts and special tools list covering direct support and general support maintenance for this equipment (TM 9-2350-314-24P-1). All mandatory replacement parts identified in the initial setup are listed in Appendix E of this manual.

Section II. GENERAL HULL MAINTENANCE INSTRUCTIONS

2-5 DISASSEMBLY AND ASSEMBLY PROCEDURES.

Complete disassembly of a component is not always necessary to make a required repair or replacement. Good judgement should be used to keep disassembly operations to a minimum.

In disassembling a unit, first follow basic inspection procedures, then remove only necessary components and subassemblies. These components may then be reduced, as necessary, into individual parts.

During disassembly, tag critical parts such as shims, bearings, and electrical harnesses and leads, to facilitate reassembly. This is especially important for electrical equipment if circuit number tags are illegible or missing.

2-5 DISASSEMBLY AND ASSEMBLY PROCEDURES - CONTINUED



Never scribe-mark bearing surfaces.

Mark gears on mating teeth by scribe marks, or with dye, indelible ink, or paint, to be certain of correct positioning at assembly. The use of chalk or crayon for marking should be avoided because of lack of permanence.

During assembly, subassemblies should be assembled first, combined into major components where possible, and then installed to form a complete component.

Records to provide repair and replacement data and statistics should be carefully prepared and maintained according to DA PAM 738-750.

2-6 REPLACEMENT OF PARTS.

Unserviceable and unrepairable assemblies will be broken down into items of issue, and serviceable parts will be returned to stock. Parts or assemblies which cannot be repaired or reconditioned will be salvaged, and new parts will be used to replace them.

When assembling components and assemblies, replace damaged keys with new ones. If screws, washers, or nuts are damaged, they must be replaced.

Gaskets, packings, preformed packings, seals, lockwashers, locknuts, self-locking nuts, self-locking screws, cotter pins, and spring pins must be replaced. Bushings must be replaced only if removed.

Springs must be replaced if broken, kinked, stressed or cracked.

If a required part is not available, reconditioning of the old part is necessary. Such parts should be inspected carefully after reconditioning to determine their suitability and probable service life. Replacement parts should be requisitioned immediately.

2-7 BALL AND ROLLER BEARINGS.

Refer to TM 9-214, "Inspection and Care of Bearings", for cleaning, inspection, and lubrication of bearings, and instructions for evaluation of bearing life.

2-8 REMOVING BURRS, SCRATCHES, AND RAISED METAL.

WARNING

Dry-cleaning solvent (P-D-680), used to clean parts, is toxic and flammable. Wear protective goggles and gloves and use only in a well-ventilated area. Avoid contact with skin, eyes, and clothes. Do not breathe vapors. Do not use near open flame or excessive heat. Do not smoke when using solvent. Failure to do so could cause **SERIOUS INJURY**. If you become dizzy while using dry-cleaning solvent, get fresh air immediately, and if necessary, get medical attention. If contact with skin or clothes is made, flush thoroughly with water. If the solvent contacts your eyes, wash them with water immediately and obtain medical aid (ref. FM 21-11).

Use a fine mill file, soft stone, or abrasive cloth (item 7, Appx B) dipped in dry-cleaning solvent (item 29, Appx B) to remove burrs, scratches, or raised metal.

When filing aluminum, clean file often to avoid lodging file with aluminum particles which will gouge work surface.

2-9 SCREW THREAD INSERTS (ONE PIECE TYPE).

When determined feasible by inspection, damaged threads should be repaired by rethreading, use of thread restorer, tap die, or by "chasing" on lathe.

Tapping holes for screw thread inserts that have mutilated threads may be repaired by drilling and tapping hole oversize and installing larger inserts or by filling tapped hole by welding, redrilling, and tapping hole to original size.

Refer to Table 2-1 for drill size and depth.

Table 2-1 Thread Inserts: Drill Size and Depth

THREAD INSERT		TAP DRILL Diameter	COUNTERSINK Diameter	REMOVAL DRILL	
Internal Thread	External Thread			Diameter	Drilling Depth
10-24 10-32	3/8-16	Q (0.332)	25/64	9/32	1/4
1/4-20 1/4-28	7/16-14	X (0.397)	29/64	11/32	1/4
5/16-18 5/16-24	1/2-13	29/64	33/64	13/32	1/4
3/8-16 3/8-24	9/16-12	33/64	37/64	15/32	1/4
7/16-14 7/16-20	5/8-11	37/64	41/64	17/32	1/4
1/2-13 1/2-20	11/16-11	41/64	45/64	19/32	1/4

2-9 SCREW THREAD INSERTS (ONE PIECE TYPE) - CONTINUED

Use the following procedure to remove and install screw thread inserts:

- 1 Drill thread insert. Refer to Table 2-1 for drill size and depth.
- 2 Deflect keys inward and break off.
- 3 Remove remainder of thread insert with a screw extractor.

NOTE

Step 4 applies to subfloor drain inserts only.

- 4 Apply zinc chromate primer coating (item 8, Appx B) to threads of subfloor drain inserts.
- 5 Install screw thread insert until 0.010 to 0.030 in. (0.25 to 0.76 mm) below surface of plate.
- 6 Drive keys in flush with plate.

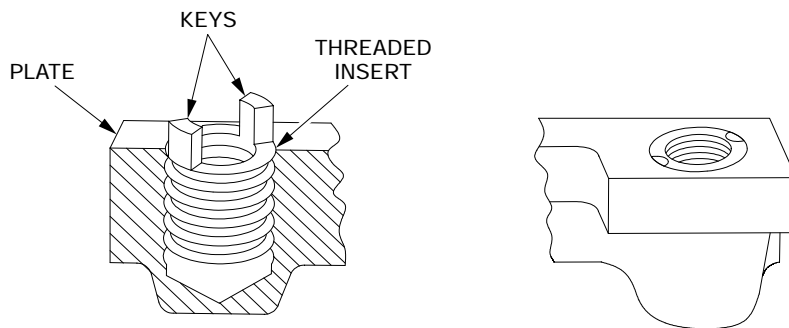
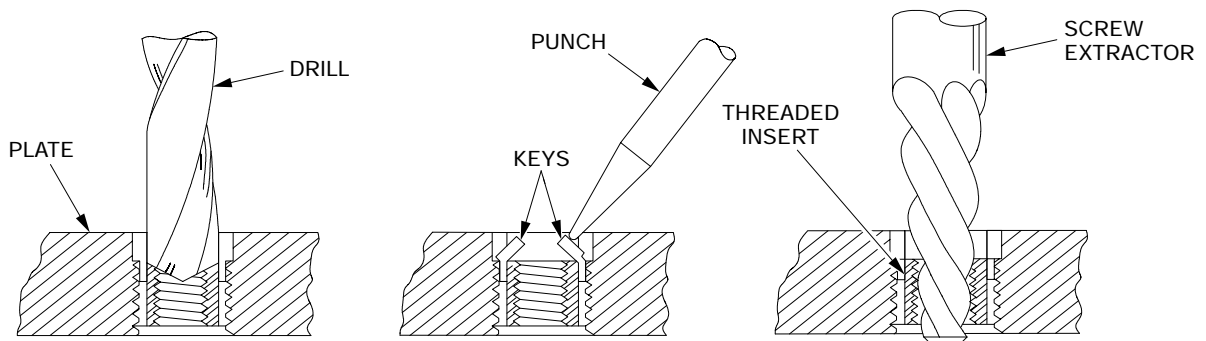

18ph082m

TM 9-2350-314-34-1

2-10 WELDING.

For welding instructions and welding materials, refer to TM 9-237.

2-11 ELECTRICAL TEST EQUIPMENT AND ELECTRICAL TESTING.

To use electrical test equipment, refer to TM 9-2350-314-20-1.

2-12 SHAFTS, GEARS, AND BEARINGS.

Gears, bearings, sleeves, and other components may be installed on the shafts as tight fits. The use of arbor press, gear pullers, or other appropriate tools for removal and installation may be required.

Section III. CLEANING, PAINTING, AND LUBRICATION

2-13 CLEANING.

Procedures for cleaning are the same for a great percentage of parts and components. Refer to TM 9-247 for instructions on cleaning and necessary cleaning materials. Refer to this TM and TM 9-2350-314-10 for specific areas to be cleaned.

Clean all parts before inspection, after repair, and before assembly.

Hands should be kept free of grease which can collect dust and dirt.

After cleaning, all parts should be covered to protect them from dust and dirt.

2-14 PAINTING.

Refer to TM 43-0139 and TB 43-0147 for information on painting.

2-15 LUBRICATION.

Refer to TM 9-2350-314-10 for lubrication instructions.

CHAPTER 3 TROUBLESHOOTING

GENERAL

This chapter provides information to help you quickly and accurately determine the cause of equipment malfunctions. It also guides you through the proper corrective actions.

Operating a malfunctioning vehicle can result in further damage to a faulty component and possible injury to personnel. By carefully inspecting and troubleshooting, you can avoid unnecessary damage and possible injury, and you can determine the causes of vehicle or component malfunctions without complete component disassembly.

The Quick Guide to Troubleshooting, paragraph 3-1, lists common malfunctions and their possible causes, then sends you to the correct troubleshooting procedure in paragraph 3-2. The troubleshooting procedures in paragraph 3-2 give step-by-step instructions for solving each problem and, when necessary, refer you to additional procedures for more detailed information.

When using a multimeter (item 31, Appx F) to troubleshoot, use probe kit (item 27, Appx F) if required.

<u>CONTENTS</u>	<u>Page</u>
3-1 QUICK GUIDE TO TROUBLESHOOTING	3-2
3-2 TROUBLESHOOTING PROCEDURES	3-5

GENERAL TROUBLESHOOTING INSTRUCTIONS

This section includes troubleshooting test and repair information for the M109A6 Howitzer hull systems and components. Electrical wiring harnesses are included in the troubleshooting procedures as reference guides only. Go to the proper chapter for detailed information on specific electrical systems.

3-1 QUICK GUIDE TO TROUBLESHOOTING.

To effectively troubleshoot the M109A6 Howitzer, follow these steps:

- 1 Determine the symptom.
- 2 Locate the symptom in the Quick Guide to Troubleshooting.
- 3 Locate the troubleshooting reference for your symptom.
- 4 Turn to the procedure identified in the Quick Guide to Troubleshooting.
- 5 Study the function description, pictorial view, and/or schematic located at the beginning of each troubleshooting section.
- 6 Perform the corrective action as required by troubleshooting procedure.
- 7 Verify that the corrective action eliminated the symptom.

3-1 QUICK GUIDE TO TROUBLESHOOTING - CONTINUED

<u>ITEM</u>	<u>SYMPTOM</u>	<u>PAGE</u>	<u>SOLUTION OR REFERENCES</u>
ACCESSORY CONTROL BOX	LEAD FILTER FAN DOES NOT OPERATE. PERSONNEL VENTILATION FAN OPERATES PROPERLY	3-5	para 3-2.a, 3-2.a.1
	PERSONNEL VENTILATION FAN DOES NOT OPERATE. LEAD FILTER FAN OPERATES PROPERLY	3-5	para 3-2.a, 3-2.a.1
AIR CLEANER BLOWER MOTORS	DO NOT OPERATE	3-22.21	para 3-2.b
CREW COMPARTMENT WARNING LIGHT AND ENCLOSURE	CREW COMPARTMENT WARNING LIGHT DOES NOT ILLUMINATE	3-23	para 3-2.c
ENGINE	ENGINE ROTATES BUT FAILS TO START		TM 9-2350-314-20-1 and TM 9-2815-202-34
	BLACK EXHAUST SMOKE IS PRESENT		TM 9-2350-314-20-1 and TM 9-2815-202-34
	DOES NOT ACCELERATE PROPERLY		TM 9-2350-314-20-1 and TM 9-2815-202-34
	ENGINE WILL NOT DELIVER RATED POWER		TM 9-2350-314-20-1 and TM 9-2815-202-34
	UNEVEN RUNNING OR STALLING		TM 9-2350-314-20-1 and TM 9-2815-202-34
	LOW OIL PRESSURE		TM 9-2350-314-20-1 and TM 9-2815-202-34
	USES EXCESSIVE FUEL		TM 9-2350-314-20-1 and TM 9-2815-202-34
	EXCESSIVE ENGINE OIL CONSUMPTION		TM 9-2350-314-20-1 and TM 9-2815-202-34
	EXCESSIVE TURBOCHARGER NOISE OR VIBRATION		TM 9-2350-314-20-1 and TM 9-2815-202-34
WHITE EXHAUST SMOKE		TM 9-2350-314-20-1 and TM 9-2815-202-34	

3-1 QUICK GUIDE TO TROUBLESHOOTING - CONTINUED

<u>ITEM</u>	<u>SYMPTOM</u>	<u>PAGE</u>	<u>SOLUTION OR REFERENCES</u>
GUN TUBE TRAVEL LOCK CONTROL BOX	DOES NOT OPERATE PROPERLY	3-26	para 3-2.d
PERSONNEL HEATER	ALL PROBLEMS		TM 9-2540-205-24&P
TRANSMISSION	EXCESSIVE OIL TEMPERATURE (ABOVE 285° F (140° C))		TM 9-2815-202-34
	BRAKES DO NOT STOP OR HOLD VEHICLE PROPERLY		TM 9-2350-314-20-1 and TM 9-2520-234-35
	POWER TRAIN WILL NOT OPERATE IN ANY RANGE		TM 9-2350-314-20-1 and TM 9-2520-234-35
	VEHICLE WILL NOT STEER IN EITHER DIRECTION		TM 9-2350-314-20-1 and TM 9-2520-234-35
	VEHICLE PULLS TO ONE SIDE WHEN NO STEER IS APPLIED		TM 9-2350-314-20-1 and TM 9-2520-234-35
	VEHICLE STEERS WELL IN ONE DIRECTION ONLY		TM 9-2350-314-20-1 and TM 9-2520-234-35
	VIBRATES EXCESSIVELY		TM 9-2815-202-34
VOLTAGE REGULATOR CONTROL BOX	DOES NOT OPERATE PROPERLY	3-34	para 3-2.e
WINTERIZATION COOLANT HEATER CONTROL BOX	DOES NOT OPERATE PROPERLY	3-38	para 3-2.f

3-2 TROUBLESHOOTING PROCEDURES

a. ACCESSORY CONTROL BOX (For vehicles with Accessory Control Box P/N 12268582).

The accessory control box consists of three circuit breakers (20, 20, and 60 amp), lead filter fan relay, fan switch and heat selector switch, personnel ventilation fan indicator light, heater indicator light, lead filter indicator light, lead filter pressure switch, two panel lights and associated wiring. The relationship of these components is shown in the diagram below.

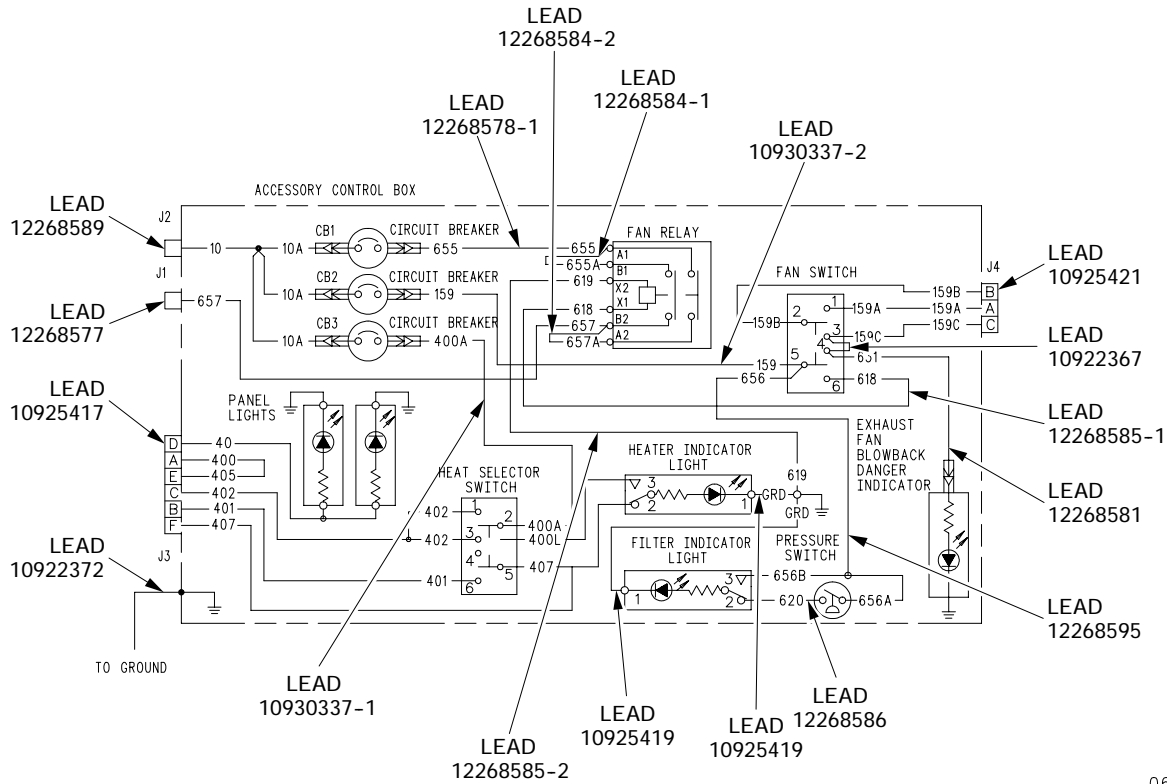

06ph001t

WARNING

Be careful when working with live circuits. Jewelry should be removed prior to working with live circuits. Failure to do this may result in personnel injury - electrical shock.

3-2 TROUBLESHOOTING PROCEDURES - CONTINUED

a. ACCESSORY CONTROL BOX (For vehicles with Accessory Control Box P/N 12268582) - CONTINUED

INITIAL SETUP

Tools

Fuel and electrical tool kit
(SC 5180-95-B08)
Multimeter (item 31, Appx F)
Probe kit (item 27, Appx F)
Vacuum hand pump (item 29, Appx F)

Equipment Conditions

Accessory control box cover
removed (TM 9-2350-314-20-1-2)

CAUTION

24 V dc is used to troubleshoot the accessory control box. Turn power supply off when disassembling components for troubleshooting to prevent arcing and possible damage to components.

NOTE

- Disassemble to extent necessary to perform circuit system checks.
- Refer to paragraph 7-5 for all repair procedures.

3-2 TROUBLESHOOTING PROCEDURES - CONTINUED

a. ACCESSORY CONTROL BOX (For vehicles with Accessory Control Box P/N 12268582) - CONTINUED

A Connect multimeter red lead to free end of ground strap lead and black lead to accessory control box.

Is continuity present?

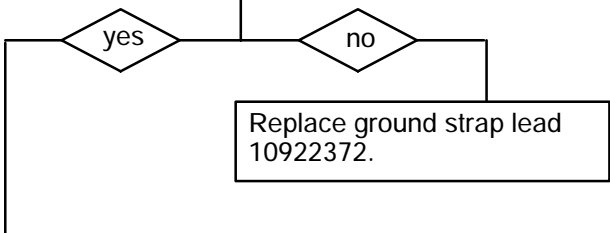

B

1. Connect power supply ground lead to ground strap and positive lead to connector J2.
2. Set power supply for 24 V dc.
3. Move fan switch to LEAD FILTER position.
4. Move multimeter red lead to connector J1.
5. Verify 24 V dc at connector J1.

Is voltage present?

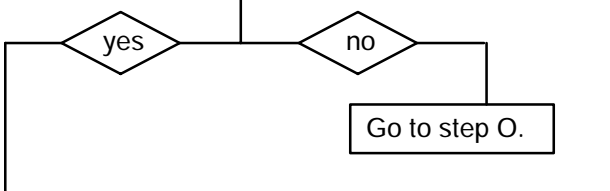

C Press CHANGE LEAD FILTER indicator.

Does indicator light illuminate?

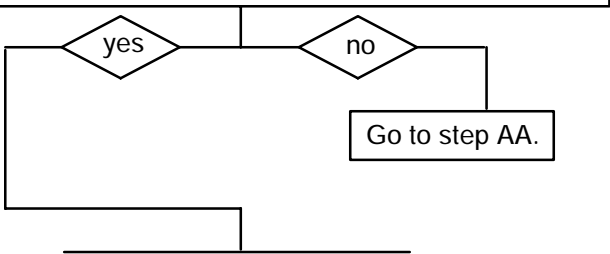

CONTINUED ON NEXT PAGE

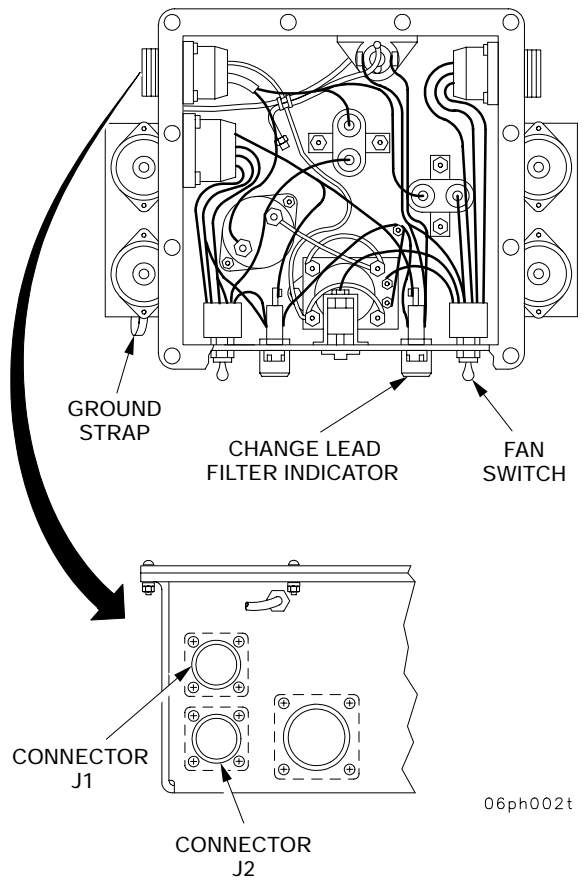

06ph002t

3-2 TROUBLESHOOTING PROCEDURES - CONTINUED

a. ACCESSORY CONTROL BOX (For vehicles with Accessory Control Box P/N 12268582) - CONTINUED

CONTINUED FROM STEP C

D 1. Connect vacuum hand pump to pressure switch input.
2. Slowly increase air pressure to 5-7 psi.

Did CHANGE LEAD FILTER indicator illuminate within tolerance?

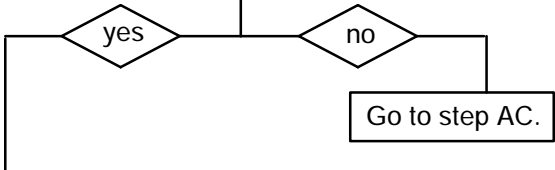

E 1. Remove vacuum hand pump from pressure switch input.
2. Move fan switch to PERSONNEL FAN position.

Does EXHAUST FAN indicator illuminate?

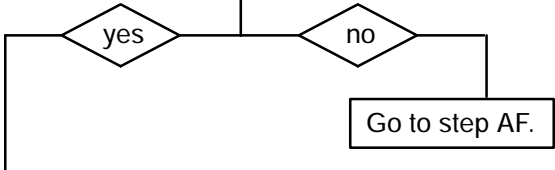

F Move multimeter red lead to connector J4, socket C.

Is 24 V dc present?

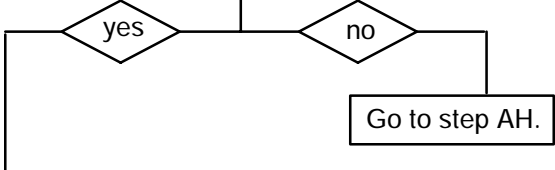

G Move multimeter red lead to connector J4, socket A and black lead to connector J4, socket B.

Is continuity present?

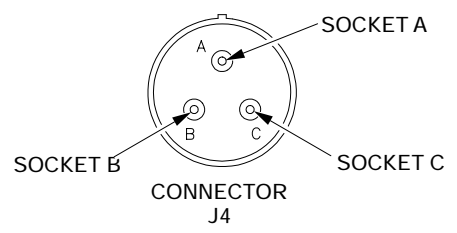
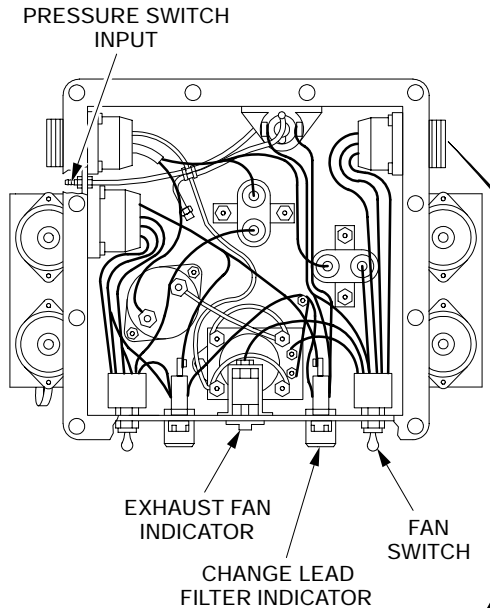
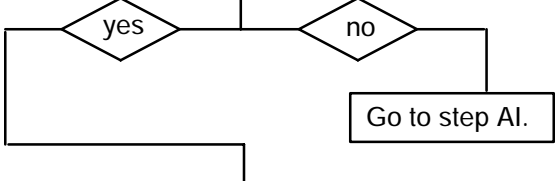

06ph003t

CONTINUED ON NEXT PAGE
Change 1

3-2 TROUBLESHOOTING PROCEDURES - CONTINUED

a. ACCESSORY CONTROL BOX (For vehicles with Accessory Control Box P/N 12268582) - CONTINUED

CONTINUED FROM STEP G

H Press heater indicator.
Does HEATER indicator light illuminate?

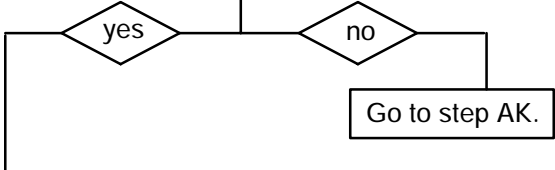

I 1. Move multimeter black lead to ground strap and red lead to connector J3, socket C.
2. Move HEAT SELECTOR switch to HIGH, then to LOW position while monitoring the voltage.
Is 24 V dc present?

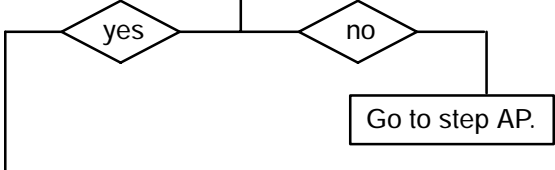

J 1. Move HEAT SELECTOR switch to HIGH position.
2. Apply 24 V dc to connector J3, socket F.
3. Move multimeter red lead to connector J3, socket B.
Is voltage present?

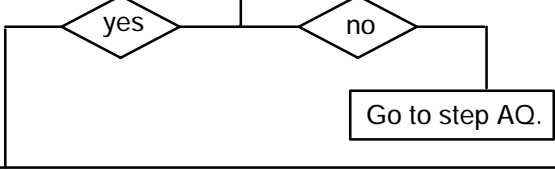

K Is HEATER indicator light illuminated?

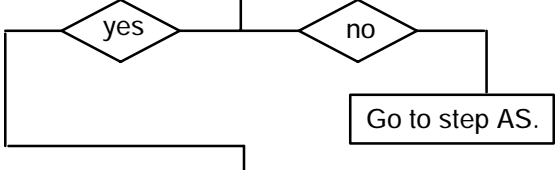

CONTINUED ON NEXT PAGE

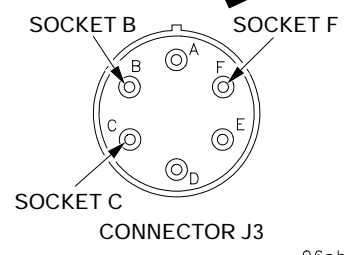
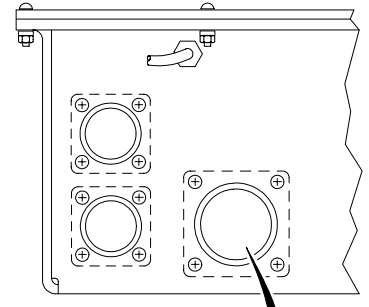
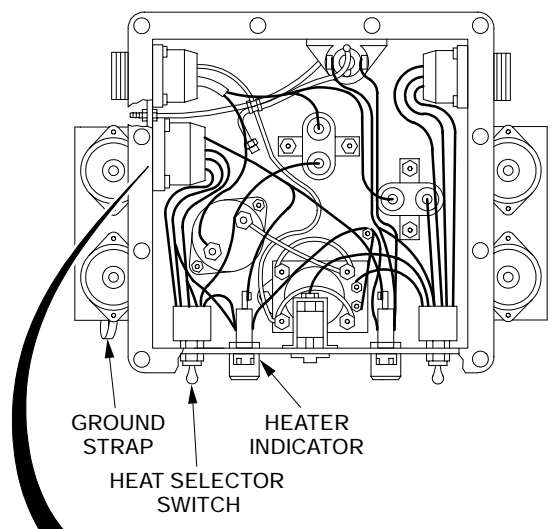

06ph004t

3-2 TROUBLESHOOTING PROCEDURES - CONTINUED

a. ACCESSORY CONTROL BOX (For vehicles with Accessory Control Box P/N 12268582) - CONTINUED

CONTINUED FROM STEP K

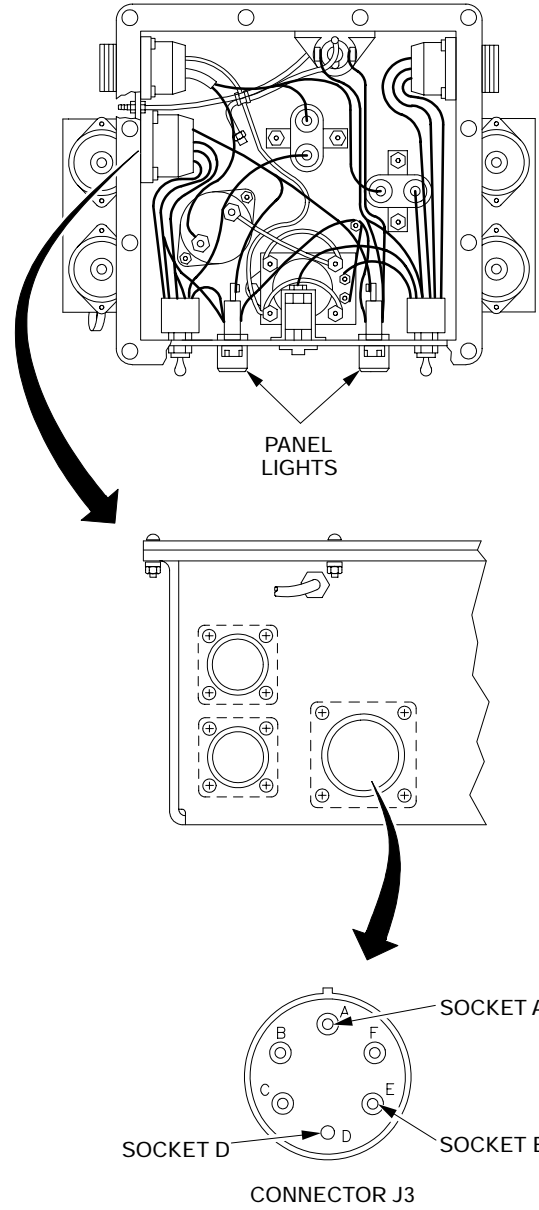
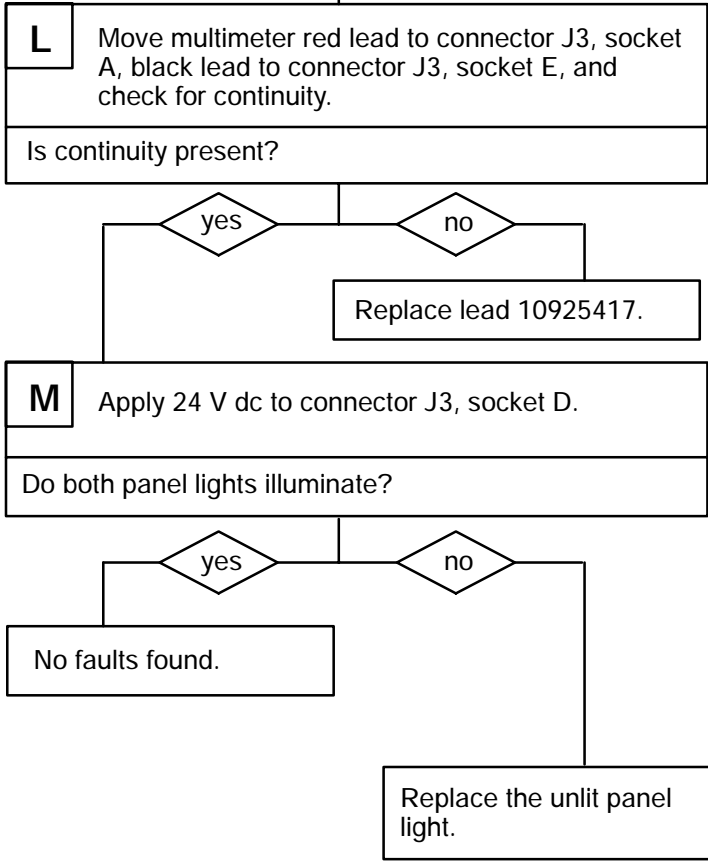

06ph005t

3-2 TROUBLESHOOTING PROCEDURES - CONTINUED

a. ACCESSORY CONTROL BOX (For vehicles with Accessory Control Box P/N 12268582) - CONTINUED

CONTINUED FROM STEP B

- O**
1. Disconnect leads 657 and 657A from fan relay pins A2 and B2.
 2. Move multimeter red lead to fan relay pin A2, then B2.

Is 24 V dc present?

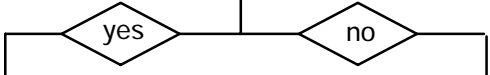

Go to step S.

- P**
1. Remove leads 655 and 655A from fan relay pins A1 and B1.
 2. Move multimeter red lead to lead 655 connector.

Is 24 V dc present?

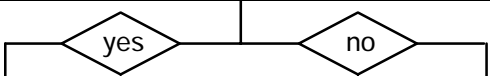

Go to step T.

- Q**
1. Reconnect leads 657 and 657A to fan relay pins A2 and B2.
 2. Remove lead 655 from circuit breaker CB1, pin 2.
 3. Move multimeter red lead to circuit breaker CB1, pin 2.

Is 24 V dc present?

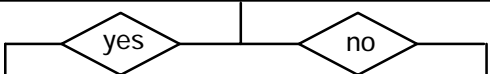

Replace lead 12268578-1.

CONTINUED ON NEXT PAGE

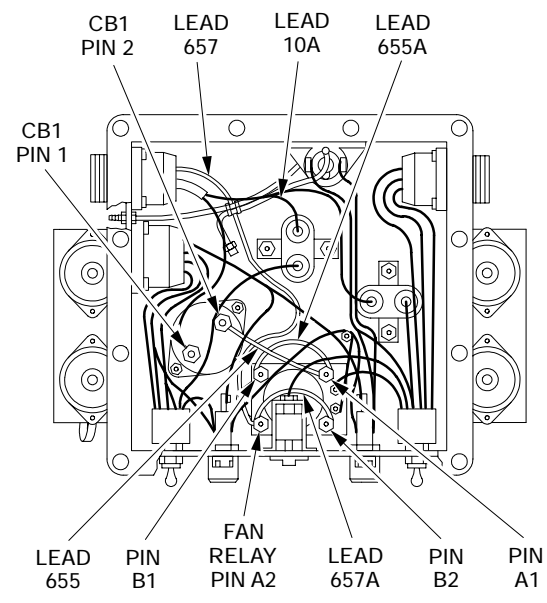

3-2 TROUBLESHOOTING PROCEDURES - CONTINUED

a. ACCESSORY CONTROL BOX (For vehicles with Accessory Control Box P/N 12268582) - CONTINUED

CONTINUED FROM STEP Q

- R**
1. Reconnect leads 655 and 655A to fan relay A1 and B1.
 2. Remove lead 10A from CB1, pin 1.
 3. Place multimeter red lead in 10A connector.

Is 24 V dc present?



Replace circuit breaker CB1.

Replace lead 12268589.

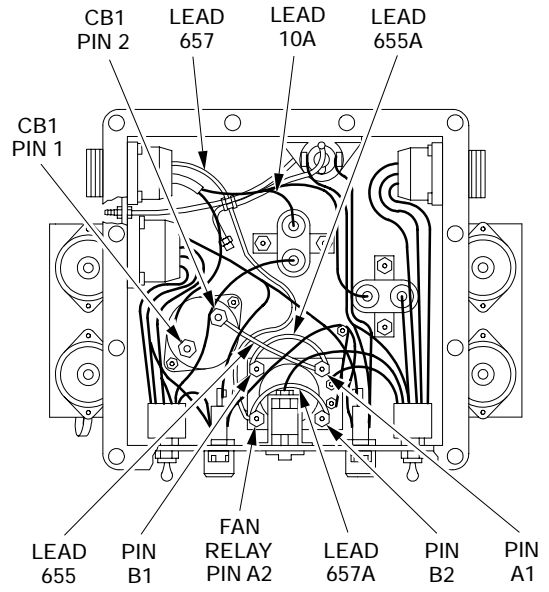

06ph006t

CONTINUED FROM STEP Q

- S** Check continuity of lead 657A.

Is continuity present?

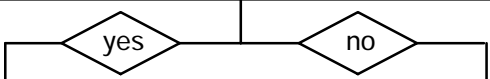

Replace lead 12268577.

Replace lead 12268584-2.

CONTINUED FROM STEP P

- T** Check continuity of lead 655A.

Is continuity present?

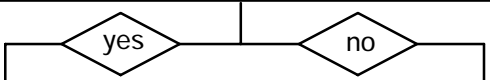

Replace lead 12268584-1.

CONTINUED ON NEXT PAGE

3-2 TROUBLESHOOTING PROCEDURES - CONTINUED

a. ACCESSORY CONTROL BOX (For vehicles with Accessory Control Box P/N 12268582) - CONTINUED

CONTINUED FROM STEP T

U

1. Disconnect lead 618 from fan relay, pin X1.
2. Move multimeter red lead to lead 618 connector and black lead to ground strap.

Is 24 V dc present?

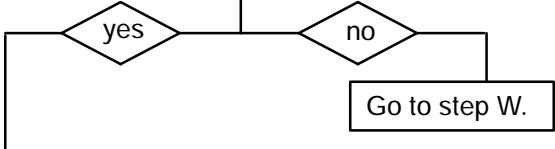

V

1. Disconnect lead 619 from fan relay, pin X2.
2. Move multimeter red lead to lead 619 connector and check for continuity.

Is continuity present?

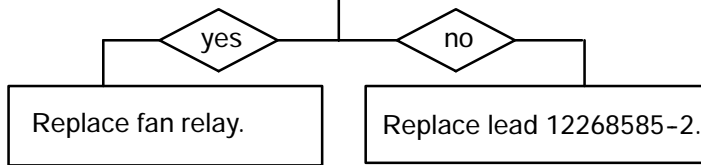

W

1. Disconnect lead 618 from fan switch, pin 6.
2. Move multimeter red lead to fan switch pin 6.

Is 24 V dc present?

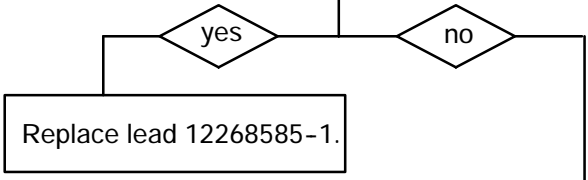

X

1. Disconnect lead 159 from fan switch, pin 5.
2. Move multimeter red lead to lead 159 connector.

Is 24 V dc present?

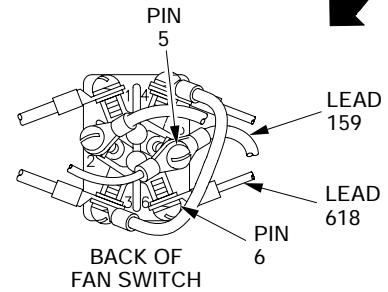
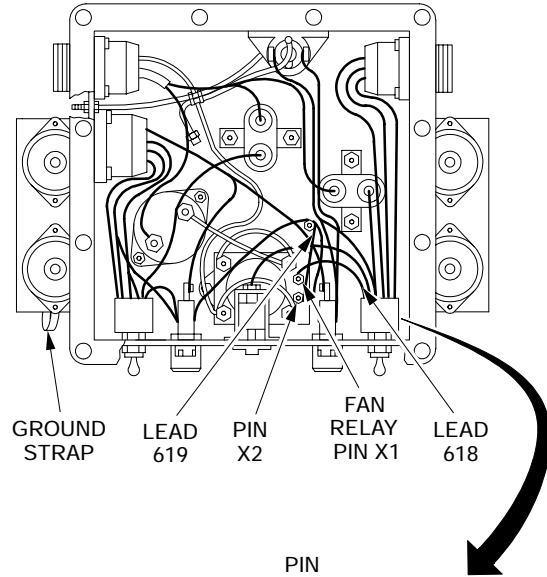
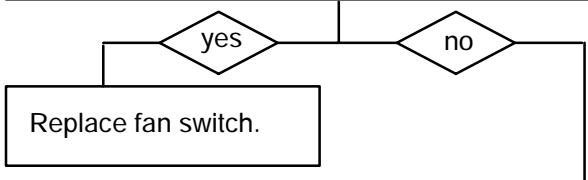

06ph007t

CONTINUED ON NEXT PAGE

3-2 TROUBLESHOOTING PROCEDURES - CONTINUED

a. ACCESSORY CONTROL BOX (For vehicles with Accessory Control Box P/N 12268582) - CONTINUED

CONTINUED FROM STEP X

Y

1. Reconnect lead 618 to fan switch pin 6.
2. Disconnect lead 159 from circuit breaker CB2, pin 2.
3. Move multimeter red lead to CB2, pin 2.

Is 24 V dc present?



Replace lead 10930337-2.

Z

1. Reconnect lead 159 to fan switch pin 5.
2. Disconnect lead 10A from circuit breaker CB2, pin 1.
3. Move multimeter red lead to lead 10A connector.

Is 24 V dc present?



Replace circuit breaker CB2.

Replace lead 12268589.

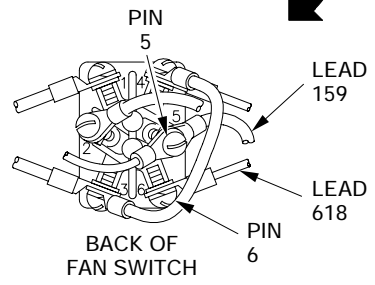
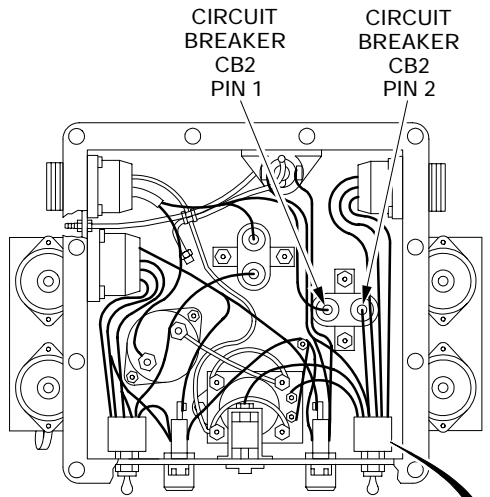

06ph008t

3-2 TROUBLESHOOTING PROCEDURES - CONTINUED

a. ACCESSORY CONTROL BOX (For vehicles with Accessory Control Box P/N 12268582) - CONTINUED

CONTINUED FROM STEP C

AA 1. Disconnect lead 656B from CHANGE LEAD FILTER indicator light, pin 3.
2. Move multimeter red lead to lead 656B connector.

Is 24 V dc present?

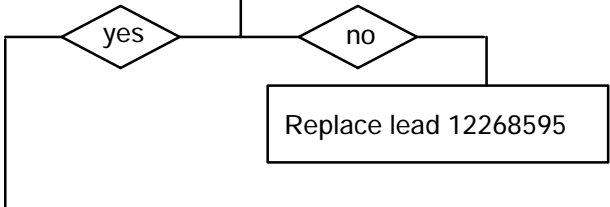

AB 1. Disconnect ground lead from CHANGE LEAD FILTER indicator light, pin 1.
2. Move multimeter red lead to ground lead connector and check for continuity.

Is continuity present?

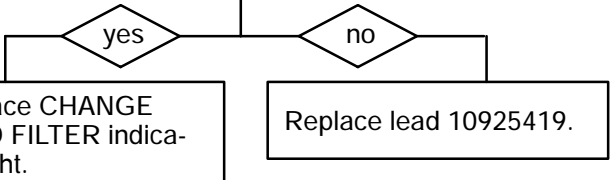

CONTINUED FROM STEP D

AC Adjust pressure switch (Refer to para 7-5).

Does CHANGE LEAD FILTER indicator light illuminate?

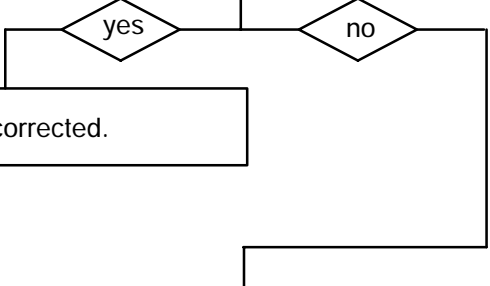

CONTINUED ON NEXT PAGE

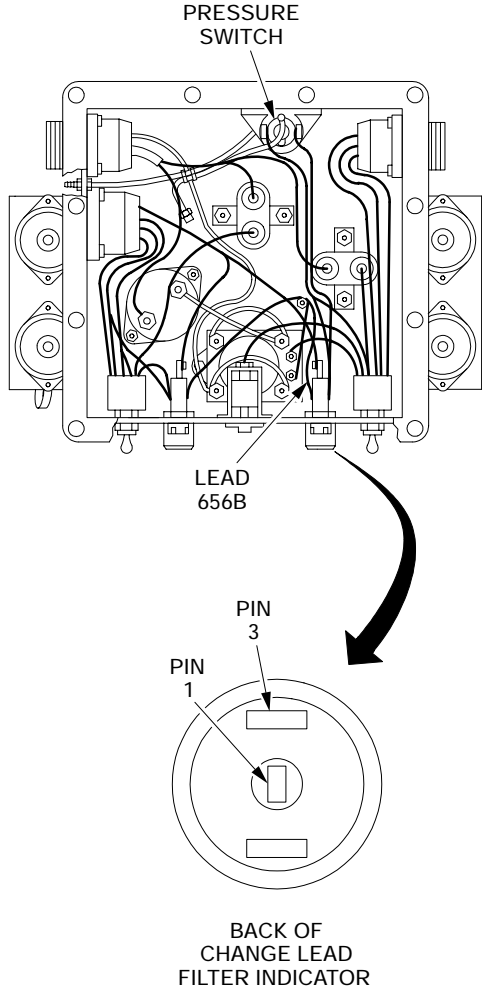

06ph009t

3-2 TROUBLESHOOTING PROCEDURES - CONTINUED

a. ACCESSORY CONTROL BOX (For vehicles with Accessory Control Box P/N 12268582) - CONTINUED

CONTINUED FROM STEP AC

AD 1. Disconnect lead 656A from pressure switch.
2. Move multimeter red lead to lead 656A connector.

Is 24 V dc present?

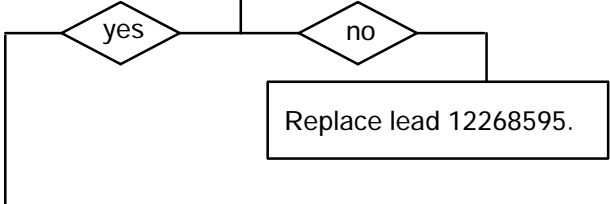

AE 1. Disconnect lead 620 from CHANGE LEAD FILTER indicator, pin 2 and pressure switch.
2. Check for continuity.

Is continuity present?

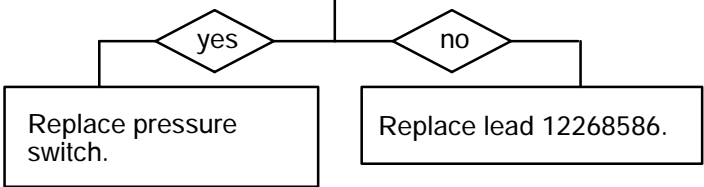

CONTINUED FROM STEP E

AF 1. Disconnect lead 631 from fan switch, pin 4 and EXHAUST FAN indicator light.
2. Move multimeter red lead to fan switch, pin 4.

Is 24 V dc present?

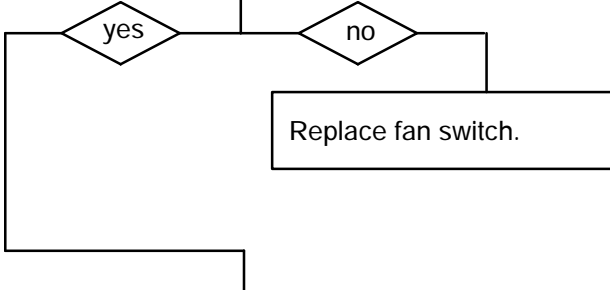

CONTINUED ON NEXT PAGE

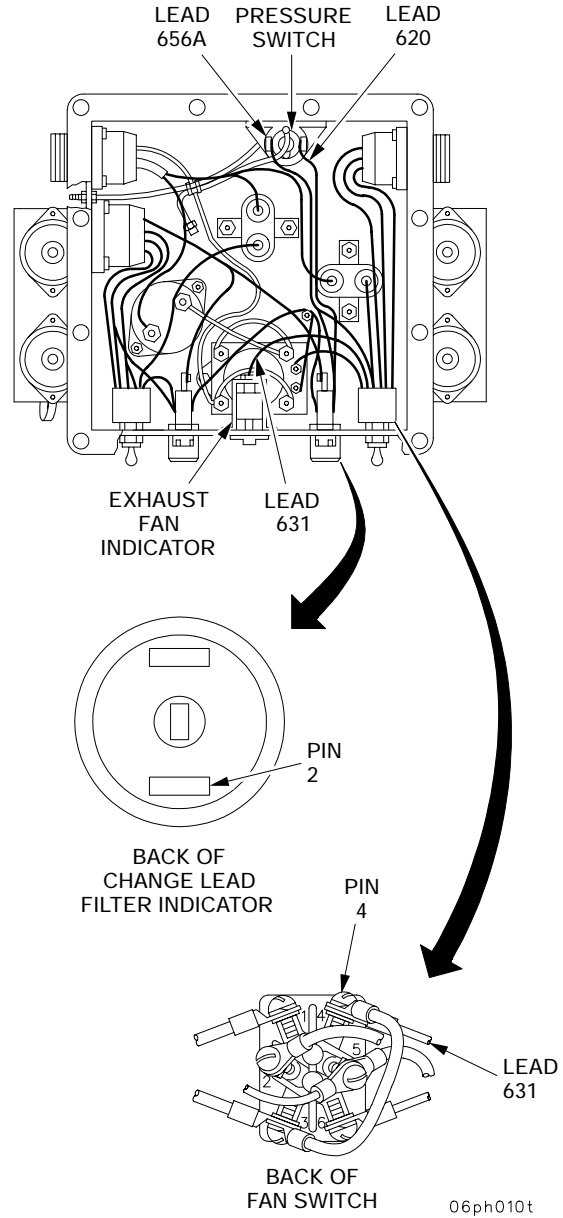

3-2 TROUBLESHOOTING PROCEDURES - CONTINUED

a. ACCESSORY CONTROL BOX (For vehicles with Accessory Control Box P/N 12268582) - CONTINUED

CONTINUED FROM STEP AF

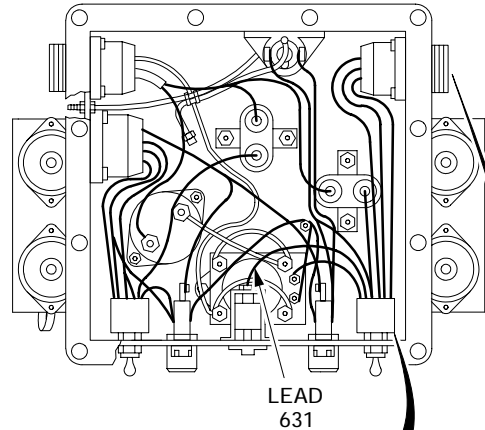
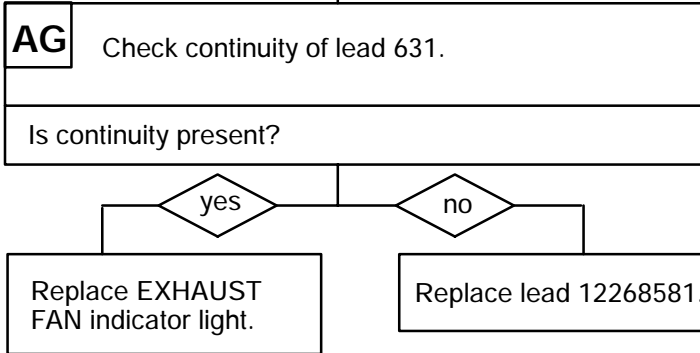

CONTINUED FROM STEP F

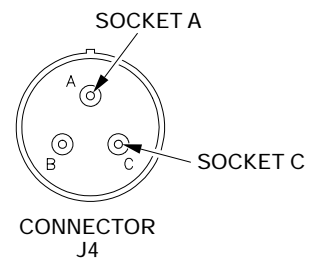
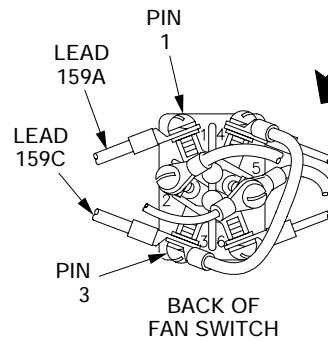
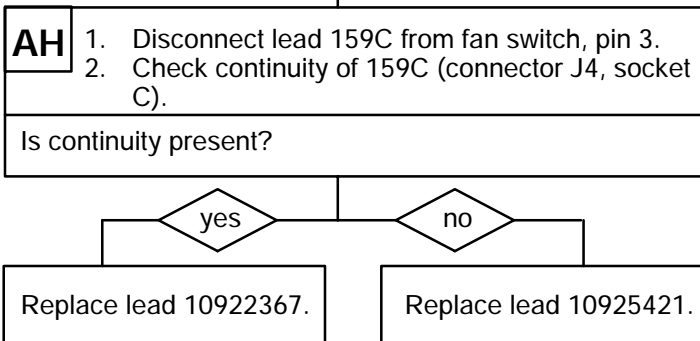

CONTINUED FROM STEP G

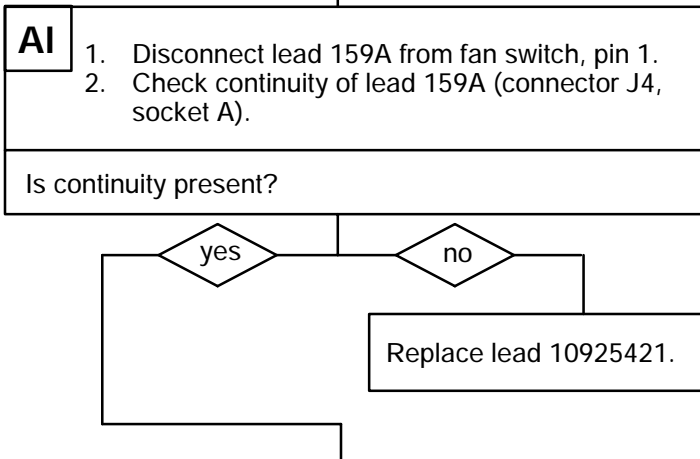

CONTINUED ON NEXT PAGE

06ph011t

3-2 TROUBLESHOOTING PROCEDURES - CONTINUED

a. ACCESSORY CONTROL BOX (For vehicles with Accessory Control Box P/N 12268582) - CONTINUED

CONTINUED FROM STEP AI

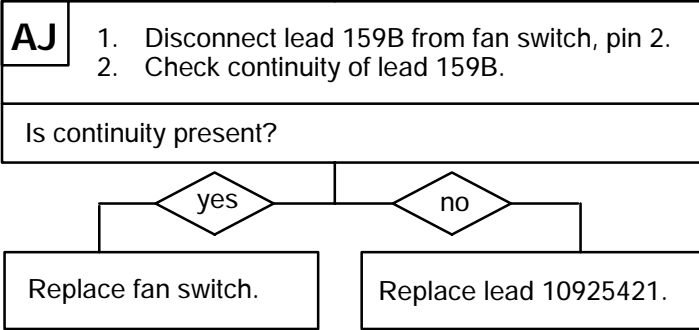

CONTINUED FROM STEP H

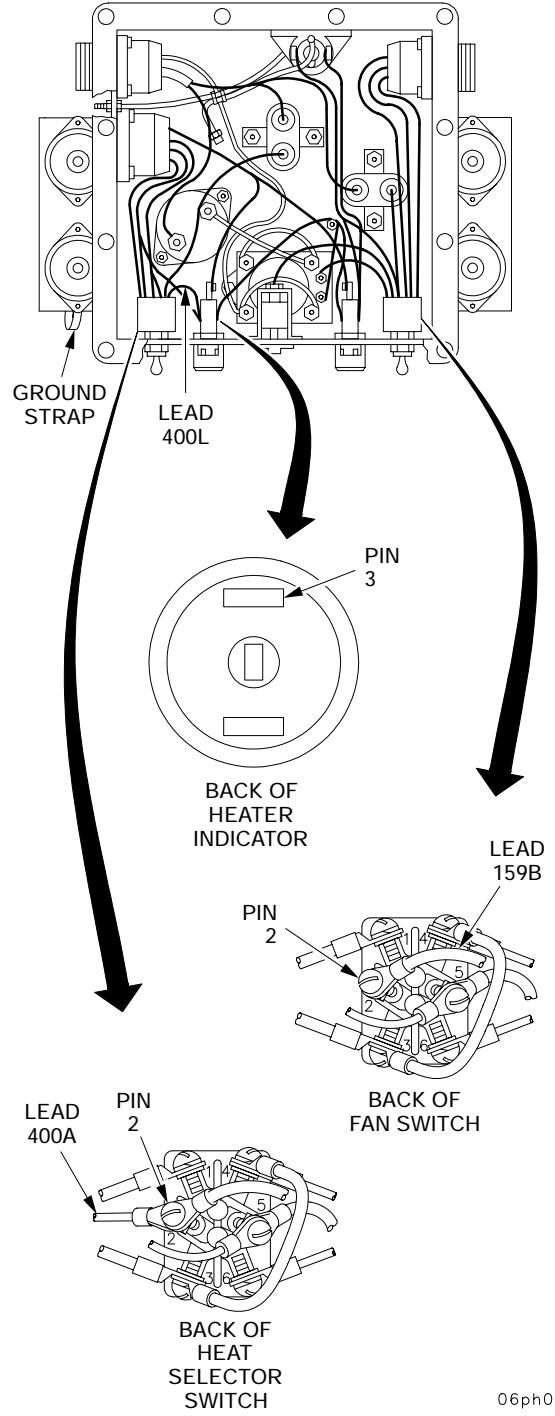
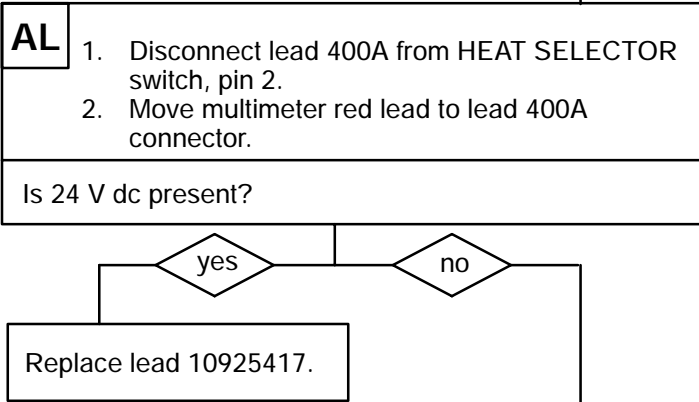
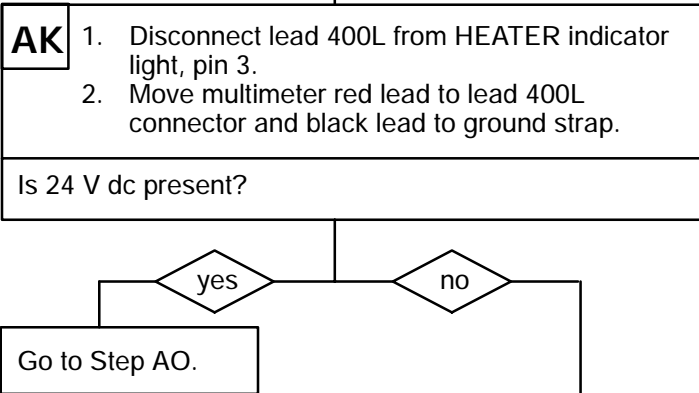

06ph012t

CONTINUED ON NEXT PAGE

3-2 TROUBLESHOOTING PROCEDURES - CONTINUED

a. ACCESSORY CONTROL BOX (For vehicles with Accessory Control Box P/N 12268582) - CONTINUED

CONTINUED FROM STEP AL

AM

1. Reconnect lead 400L to HEATER indicator light, pin 3.
2. Disconnect lead 400A from circuit breaker CB3.
3. Move multimeter red lead to CB3, pin 2.

Is 24 V dc present?

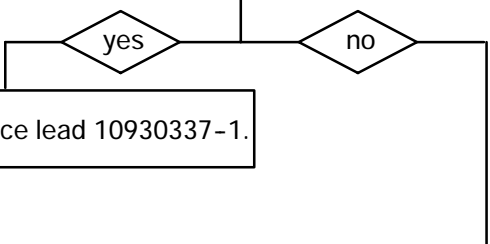

AN

1. Reconnect lead 400A to HEAT SELECTOR switch, pin 2.
2. Disconnect lead 10A from circuit breaker CB3, pin 1.
3. Move multimeter red lead to 10A connector.

Is 24 V dc present?

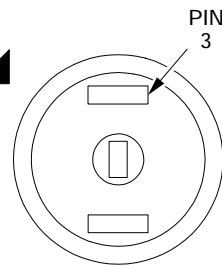
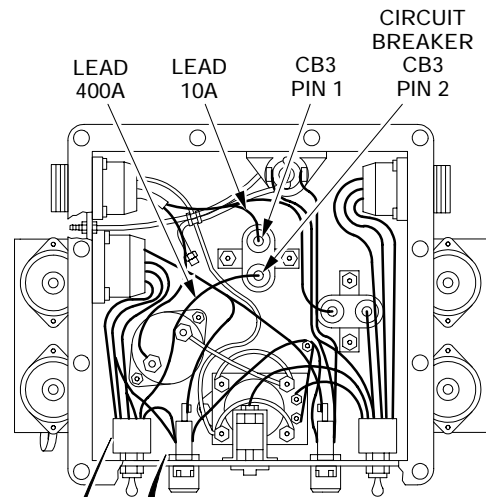
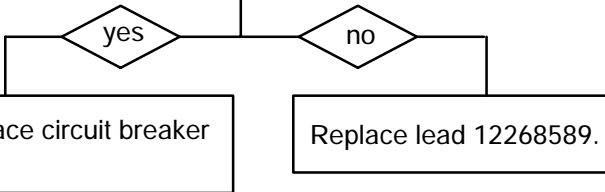

BACK OF HEATER INDICATOR

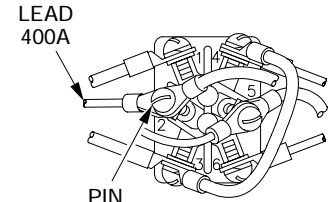

BACK OF HEAT SELECTOR SWITCH

06ph013t

3-2 TROUBLESHOOTING PROCEDURES - CONTINUED

a. ACCESSORY CONTROL BOX (For vehicles with Accessory Control Box P/N 12268582) - CONTINUED

CONTINUED FROM STEP AK

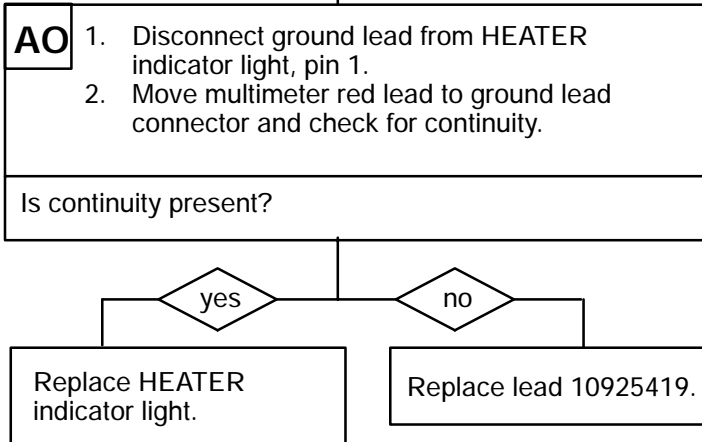

CONTINUED FROM STEP I

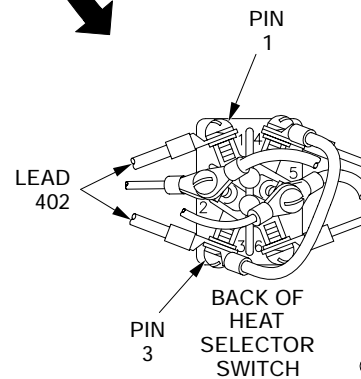
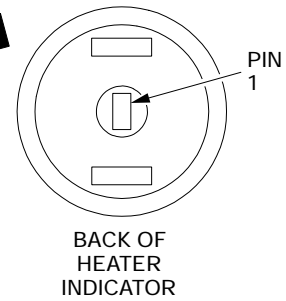
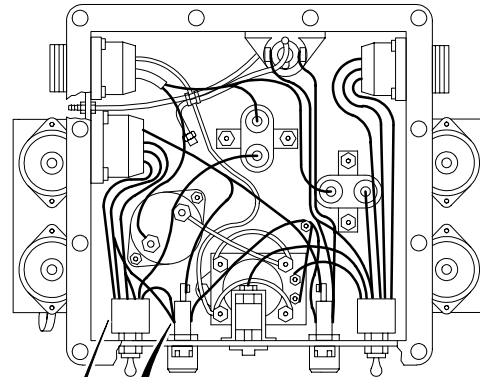
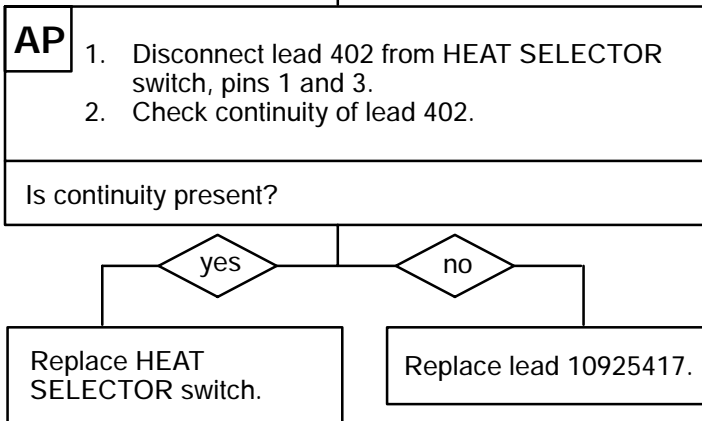

06ph014t

3-2 TROUBLESHOOTING PROCEDURES - CONTINUED

a. ACCESSORY CONTROL BOX (For vehicles with Accessory Control Box P/N 12268582) - CONTINUED

CONTINUED FROM STEP J

- AQ**
1. Disconnect lead 407 from HEAT SELECTOR switch, pin 5.
 2. Move multimeter red lead to lead 407 connector.

Is 24 V dc present?

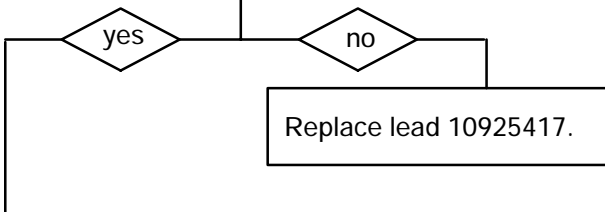

- AR**
1. Disconnect lead 401 from HEAT SELECTOR switch, pin 6.
 2. Check continuity of lead 401.

Is continuity present?

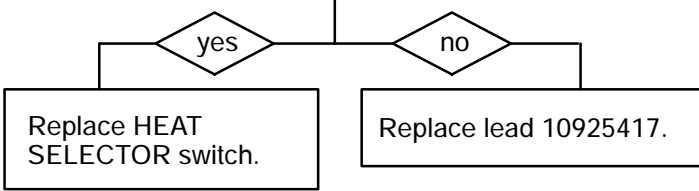

CONTINUED FROM STEP K

- AS**
1. Disconnect lead 407 from HEATER indicator light, pin 2.
 2. Move multimeter red lead to lead 407 connector.

Is 24 V dc present?

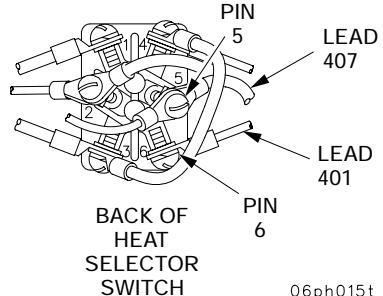
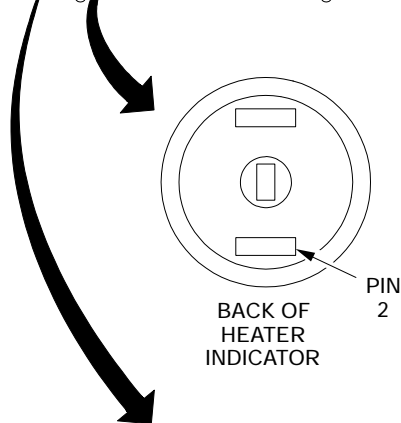
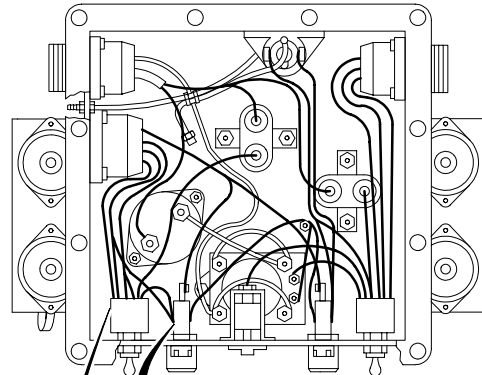
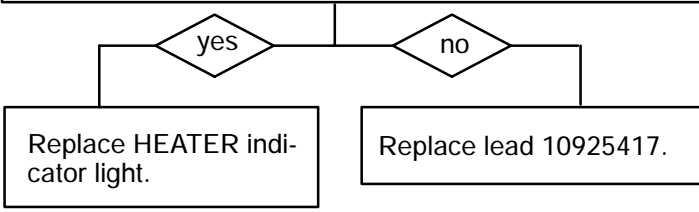

06ph015t

END OF TASK

3-2 TROUBLESHOOTING PROCEDURES - CONTINUED

a.1 ACCESSORY CONTROL BOX (For vehicles with Accessory Control Box P/N 12268547).

The accessory control box consists of three circuit breakers (20, 20, and 60 amp), lead filter fan relay, fan switch, heater control switch, heater control relay, heat selector switch, personnel ventilation fan indicator light, heater indicator light, lead filter indicator light, lead filter pressure switch, two panel lights and associated wiring. The relationship of these components is shown in the diagram below.

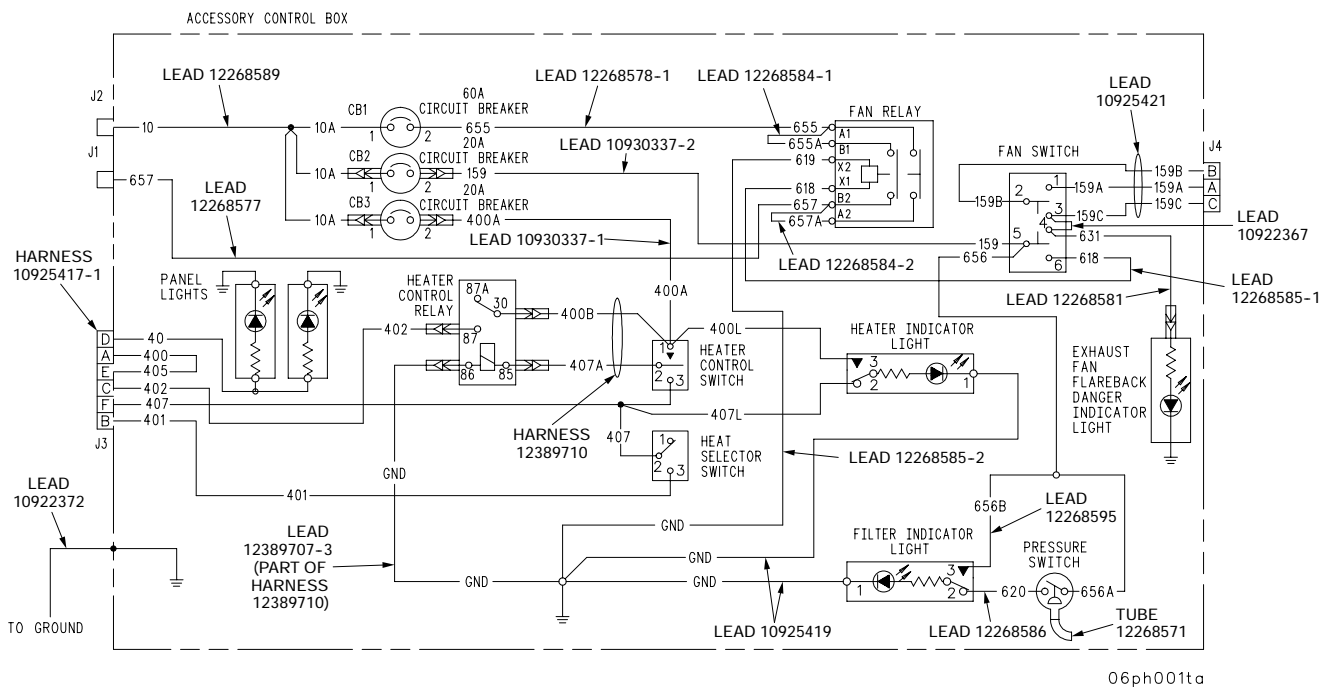

06ph001t

WARNING

Be careful when working with live circuits. Jewelry should be removed prior to working with live circuits. Failure to do this may result in personnel injury - electrical shock.

3-2 TROUBLESHOOTING PROCEDURES - CONTINUED

a.1 ACCESSORY CONTROL BOX (For vehicles with Accessory Control Box P/N 12268547) - CONTINUED

INITIAL SETUP

Tools

Fuel and electrical tool kit
(SC 5180-95-B08)
Multimeter (item 31, Appx F)
Probe kit (item 27, Appx F)
Vacuum hand pump (item 29, Appx F)

Equipment Conditions

Accessory control box cover
removed (para 7-5A)

CAUTION

24 V dc is used to troubleshoot the accessory control box. Turn power supply off when disassembling components for troubleshooting to prevent arcing and possible damage to components.

NOTE

- Disassemble to extent necessary to perform circuit system checks.
- Refer to paragraph 7-5A for all repair procedures.

3-2 TROUBLESHOOTING PROCEDURES - CONTINUED

a.1 ACCESSORY CONTROL BOX (For vehicles with Accessory Control Box P/N 12268547) - CONTINUED

A Connect multimeter red lead to free end of ground strap lead and black lead to accessory control box.

Is continuity present?

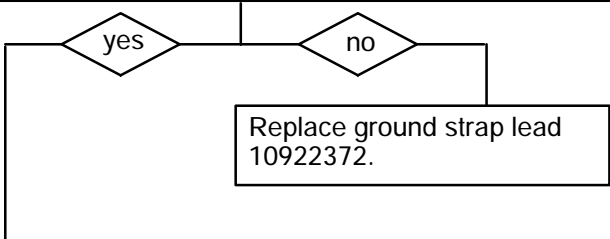

B

1. Connect power supply ground lead to ground strap and positive lead to connector J2.
2. Set power supply for 24 V dc.
3. Move fan switch to LEAD FILTER position.
4. Move multimeter red lead to connector J1.
5. Verify 24 V dc at connector J1.

Is voltage present?

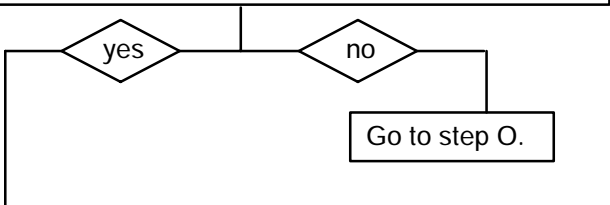

C Press CHANGE LEAD FILTER indicator.

Does indicator light illuminate?

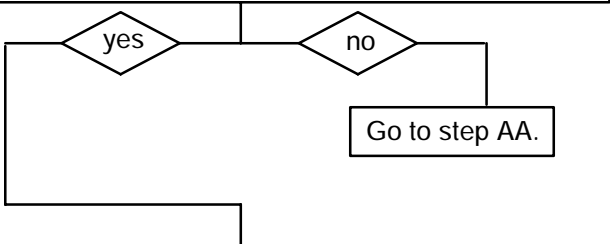

CONTINUED ON NEXT PAGE

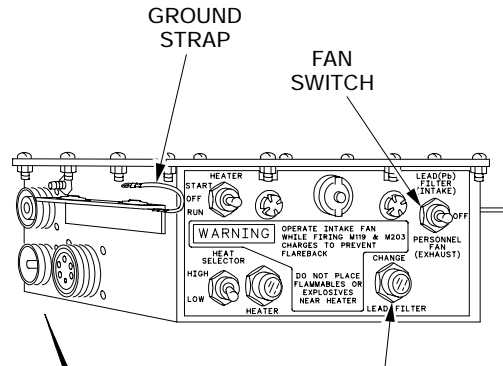

CHANGE LEAD FILTER INDICATOR

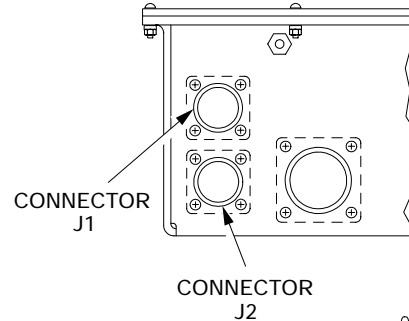

06ph002ta

3-2 TROUBLESHOOTING PROCEDURES - CONTINUED

a.1 ACCESSORY CONTROL BOX (For vehicles with Accessory Control Box P/N 12268547) - CONTINUED

CONTINUED FROM STEP C

D 1. Connect vacuum hand pump to pressure switch input.
2. Slowly increase air pressure to 5-7 psi.

Did CHANGE LEAD FILTER indicator illuminate within tolerance?

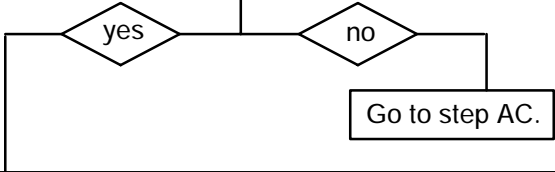

E 1. Remove vacuum hand pump from pressure switch input.
2. Move fan switch to PERSONNEL FAN position.

Does EXHAUST FAN indicator illuminate?

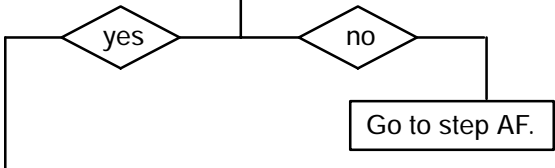

F Move multimeter red lead to connector J4, socket C.

Is 24 V dc present?

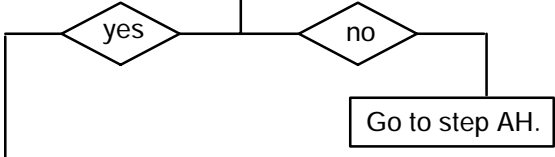

G 1. Disconnect lead from ground lead.
2. Move multimeter red lead to connector J4, socket A and black lead to connector J4, socket B.

Is continuity present?

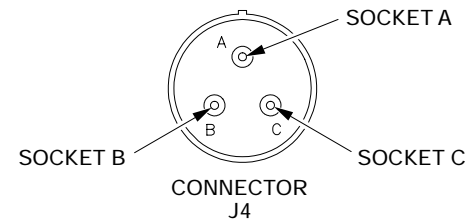
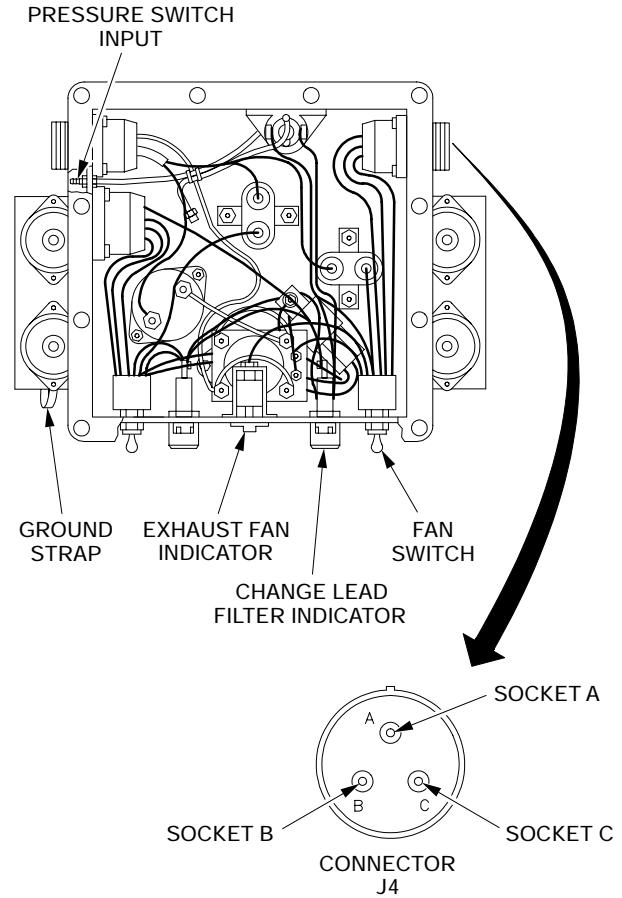
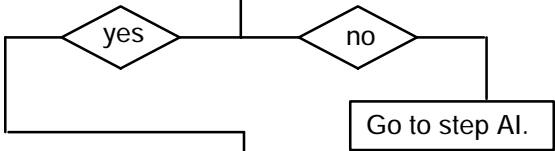

06ph003ta

CONTINUED ON NEXT PAGE

3-2 TROUBLESHOOTING PROCEDURES - CONTINUED

a.1 ACCESSORY CONTROL BOX (For vehicles with Accessory Control Box P/N 12268547) - CONTINUED

CONTINUED FROM STEP G

H 1. Connect lead to ground strap.
2. Press heater indicator.

Does HEATER indicator light illuminate?

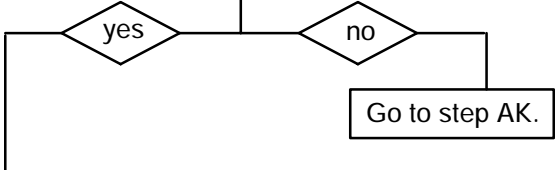

I 1. Move multimeter black lead to ground strap and red lead to connector J3, socket C.
2. Hold HEATER control switch in START position.

Is 24 V dc present?

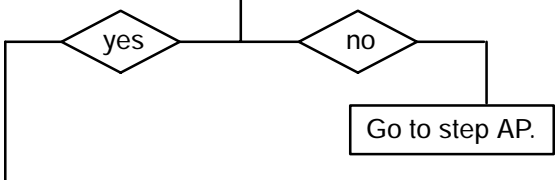

J 1. Connect a second lead from the 24 V dc power supply positive output to connector J3, socket F.
2. Set HEATER control switch to RUN position.
3. Set HEAT SELECTOR switch to HIGH position.
4. Make sure multimeter black lead is connected to ground strap and red lead to connector J3, socket C.

Is 24 V dc present?

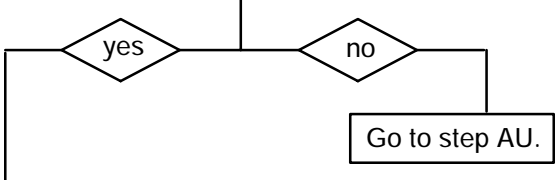

K Is HEATER indicator light illuminated?

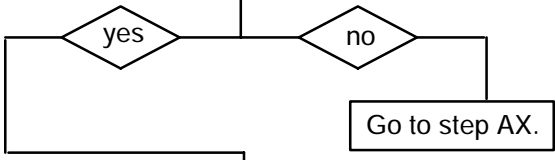

CONTINUED ON NEXT PAGE

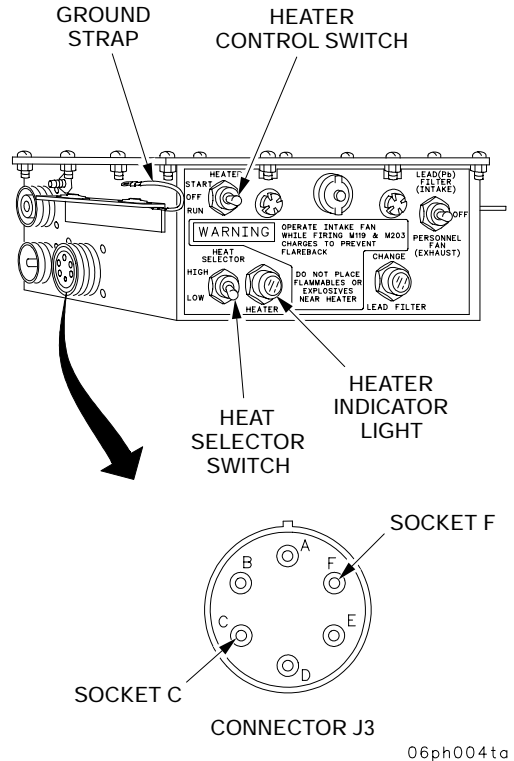

06ph004ta

3-2 TROUBLESHOOTING PROCEDURES - CONTINUED

a.1 ACCESSORY CONTROL BOX (For vehicles with Accessory Control Box P/N 12268547) - CONTINUED

CONTINUED FROM STEP K

L 1. Disconnect lead from ground strap.
2. Move multimeter red lead to connector J3, socket A, black lead to connector J3, socket E, and check for continuity.

Is continuity present?

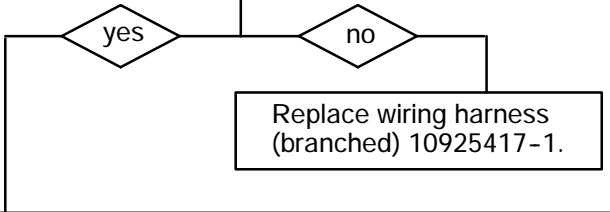

M 1. Connect lead to ground strap.
2. Move multimeter red lead to connector J3, socket B and black lead to ground strap.

Is 24 V dc present?

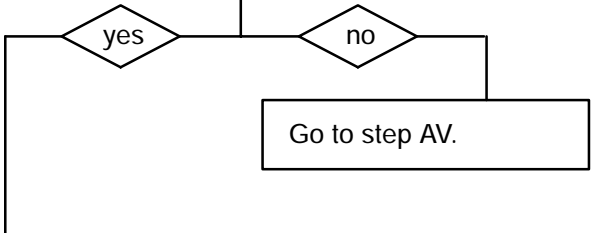

N 1. Set HEAT SELECTOR switch to LOW position.
2. Make sure red lead is connected to J3, socket B and black lead to ground strap.

Is 24 V dc present?

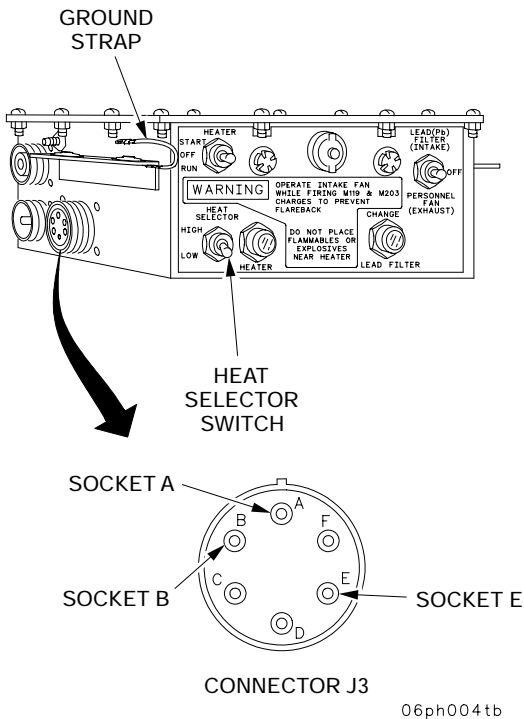
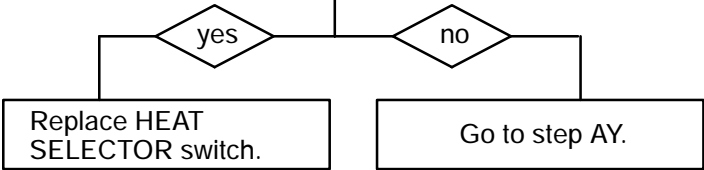

06ph004tb

3-2 TROUBLESHOOTING PROCEDURES - CONTINUED

a.1 ACCESSORY CONTROL BOX (For vehicles with Accessory Control Box P/N 12268547) - CONTINUED

CONTINUED FROM STEP B

- O**
1. Disconnect leads 657 and 657A from fan relay pins A2 and B2.
 2. Move multimeter red lead to fan relay pin A2, then B2.

Is 24 V dc present?



Go to step S.

- P**
1. Remove leads 655 and 655A from fan relay pins A1 and B1.
 2. Move multimeter red lead to lead 655 connector.

Is 24 V dc present?

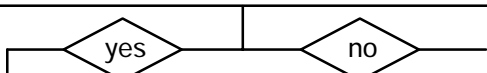

Go to step T.

- Q**
1. Reconnect leads 657 and 657A to fan relay pins A2 and B2.
 2. Remove lead 655 from circuit breaker CB1, pin 2.
 3. Move multimeter red lead to circuit breaker CB1, pin 2.

Is 24 V dc present?

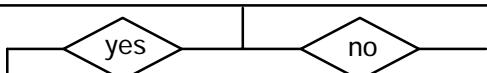

Replace lead 12268578-1.

CONTINUED ON NEXT PAGE

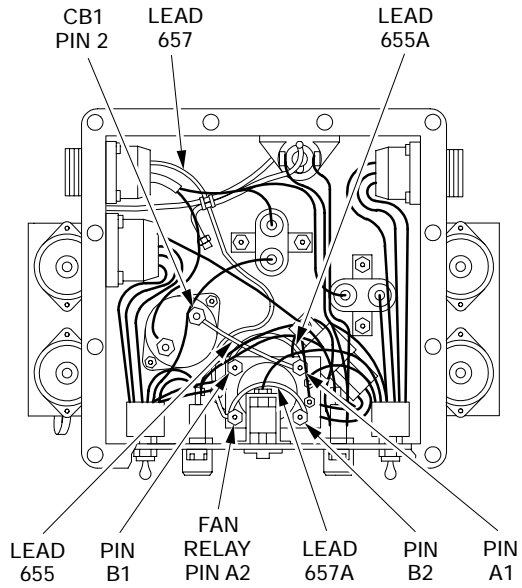

06ph006ta

3-2 TROUBLESHOOTING PROCEDURES - CONTINUED

a.1 ACCESSORY CONTROL BOX (For vehicles with Accessory Control Box P/N 12268547) - CONTINUED

CONTINUED FROM STEP Q

- | | |
|----------|--|
| R | <ol style="list-style-type: none"> 1. Reconnect lead 655 to fan relay A1 and lead 655A to fan relay A1 and B1. 2. Remove lead 10A from CB1, pin 1. 3. Place multimeter red lead in 10A connector. |
|----------|--|

Is 24 V dc present?

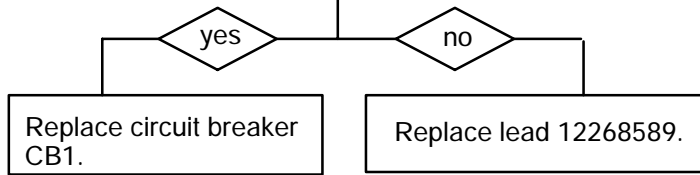

CONTINUED FROM STEP Q

- | | |
|----------|--|
| S | <ol style="list-style-type: none"> 1. Disconnect lead from ground strap. 2. Check continuity of lead 657A. |
|----------|--|

Is continuity present?

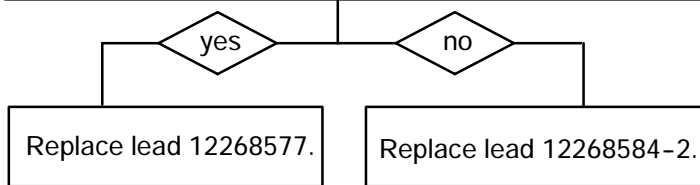

CONTINUED FROM STEP P

- | | |
|----------|--|
| T | <ol style="list-style-type: none"> 1. Disconnect lead from ground strap. 2. Check continuity of lead 655A. |
|----------|--|

Is continuity present?

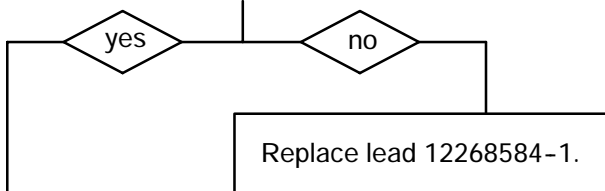

CONTINUED ON NEXT PAGE

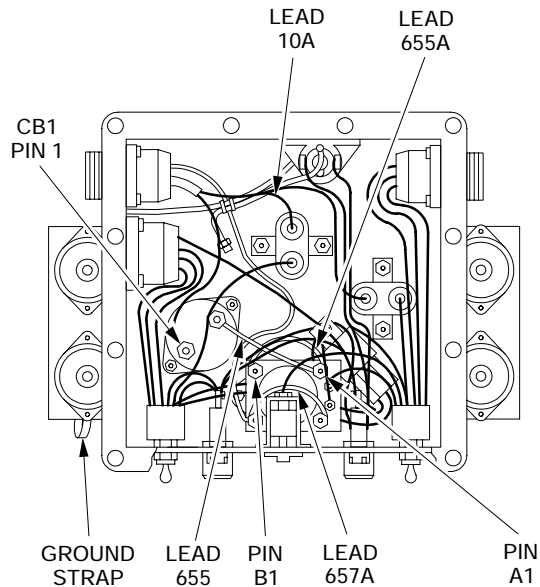

06ph006tb

3-2 TROUBLESHOOTING PROCEDURES - CONTINUED

a.1 ACCESSORY CONTROL BOX (For vehicles with Accessory Control Box P/N 12268547) - CONTINUED

CONTINUED FROM STEP T

U

1. Disconnect lead 618 from fan relay, pin X1.
2. Connect lead to ground strap.
3. Move multimeter red lead to lead 618 connector and black lead to ground strap.

Is 24 V dc present?

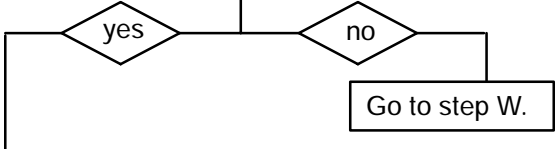

V

1. Disconnect lead from ground strap.
2. Disconnect lead 619 from fan relay, pin X2.
3. Move multimeter red lead to lead 619 connector and black lead to ground strap. Check for continuity.

Is continuity present?

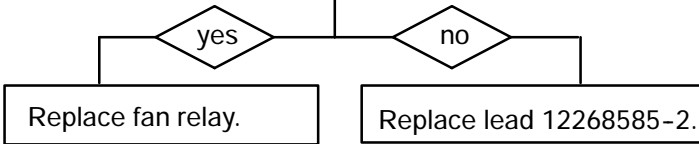

CONTINUED FROM STEP U

W

1. Disconnect lead 618 from fan switch, pin 6.
2. Move multimeter red lead to fan switch pin 6 and black lead to ground strap.

Is 24 V dc present?

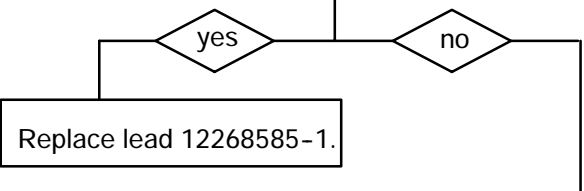

X

1. Disconnect lead 159 from fan switch, pin 5.
2. Move multimeter red lead to lead 159 connector and black lead to ground strap.

Is 24 V dc present?

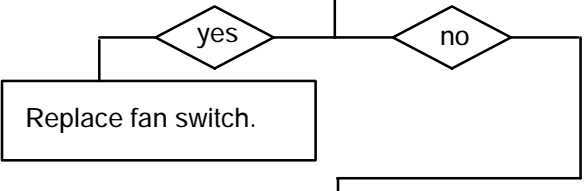

CONTINUED ON NEXT PAGE

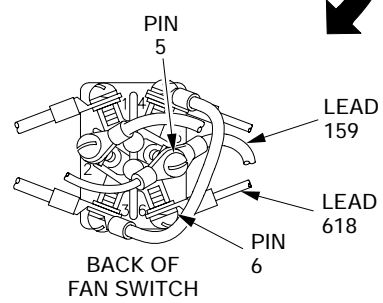
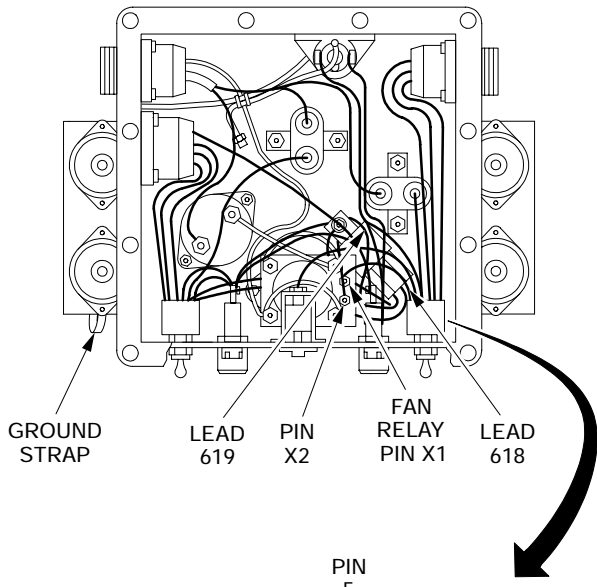

06ph007ta

3-2 TROUBLESHOOTING PROCEDURES - CONTINUED

a.1 ACCESSORY CONTROL BOX (For vehicles with Accessory Control Box P/N 12268547) - CONTINUED

CONTINUED FROM STEP X

Y	<ol style="list-style-type: none"> 1. Reconnect lead 618 to fan switch pin 6. 2. Disconnect lead 159 from circuit breaker CB2, pin 2. 3. Move multimeter red lead to CB2, pin 2 and black lead to ground strap.
Is 24 V dc present?	

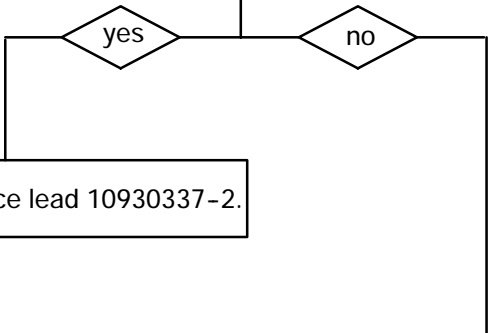

Z	<ol style="list-style-type: none"> 1. Reconnect lead 159 to fan switch pin 5. 2. Disconnect lead 10A from circuit breaker CB2, pin 1. 3. Move multimeter red lead to lead 10A connector and black lead to ground strap.
Is 24 V dc present?	

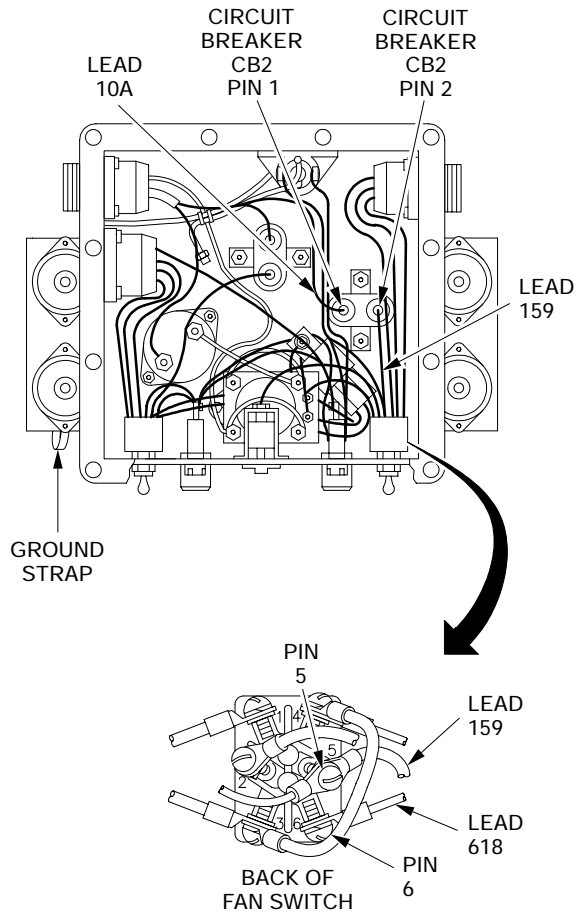
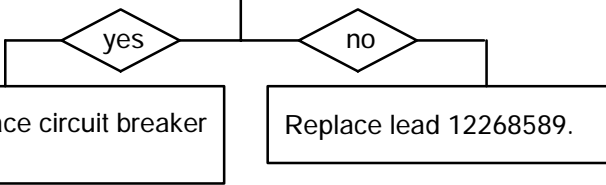

06ph008ta

3-2 TROUBLESHOOTING PROCEDURES - CONTINUED

a.1 ACCESSORY CONTROL BOX (For vehicles with Accessory Control Box P/N 12268547) - CONTINUED

CONTINUED FROM STEP C

- AA**
1. Disconnect lead 656B from CHANGE LEAD FILTER indicator light, pin 3.
 2. Move multimeter red lead to lead 656B connector.

Is 24 V dc present?

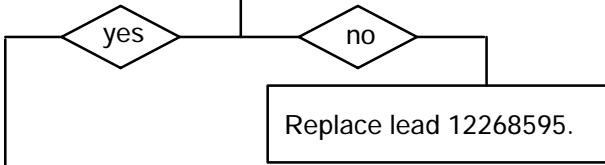

- AB**
1. Disconnect lead from ground strap.
 2. Disconnect ground lead from CHANGE LEAD FILTER indicator light, pin 1.
 3. Move multimeter red lead to ground lead connector and check for continuity.

Is continuity present?

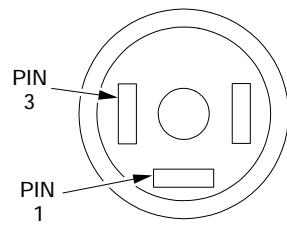
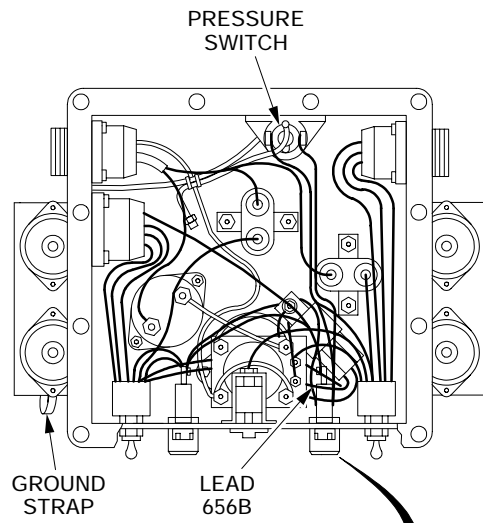
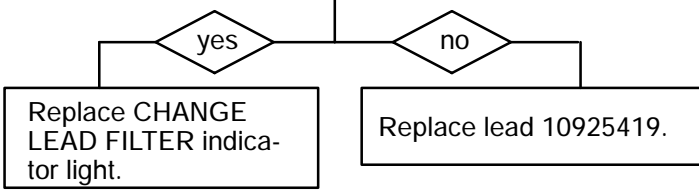

BACK OF CHANGE LEAD FILTER INDICATOR

06ph009ta

CONTINUED FROM STEP D

- AC** Adjust pressure switch (Refer to para 7-5A).

Does CHANGE LEAD FILTER indicator light illuminate?

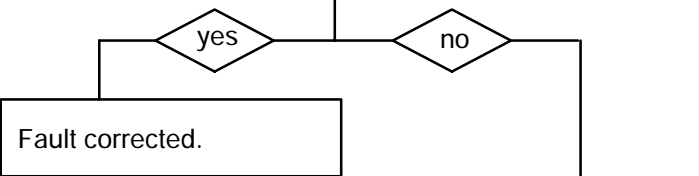

CONTINUED ON NEXT PAGE

3-2 TROUBLESHOOTING PROCEDURES - CONTINUED

a.1 ACCESSORY CONTROL BOX (For vehicles with Accessory Control Box P/N 12268547) - CONTINUED

CONTINUED FROM STEP AC

AD 1. Disconnect lead 656A from pressure switch.
2. Move multimeter red lead to lead 656A connector.

Is 24 V dc present?

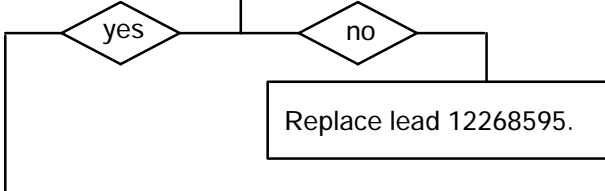

AE 1. Disconnect lead from ground strap.
2. Disconnect lead 620 from CHANGE LEAD FILTER indicator, pin 2 and pressure switch.
3. Check for continuity.

Is continuity present?

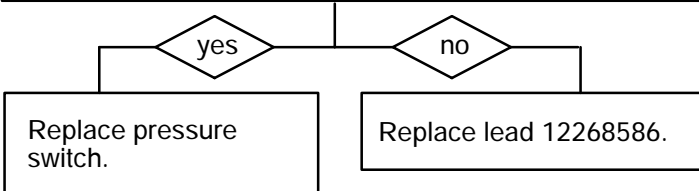

CONTINUED FROM STEP E

AF 1. Disconnect lead 631 from fan switch, pin 4 and EXHAUST FAN indicator light.
2. Move multimeter red lead to fan switch, pin 4.

Is 24 V dc present?

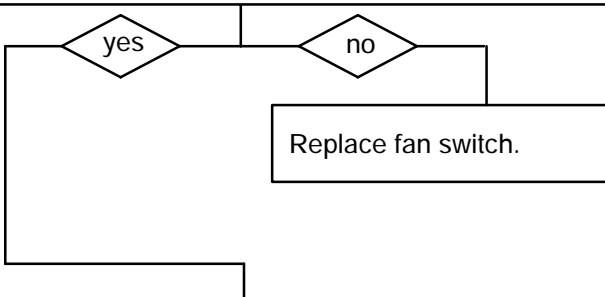

CONTINUED ON NEXT PAGE

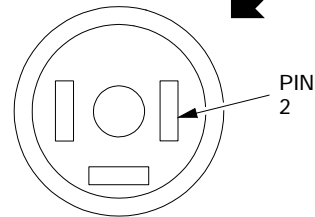
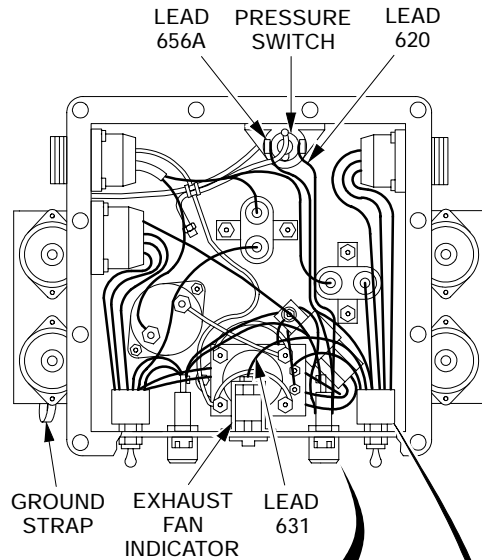

BACK OF CHANGE LEAD FILTER INDICATOR

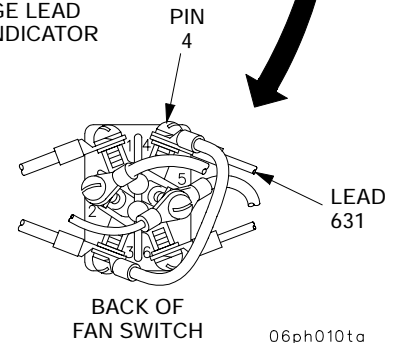

06ph010ta

3-2 TROUBLESHOOTING PROCEDURES - CONTINUED

a.1 ACCESSORY CONTROL BOX (For vehicles with Accessory Control Box P/N 12268547) - CONTINUED

CONTINUED FROM STEP AF

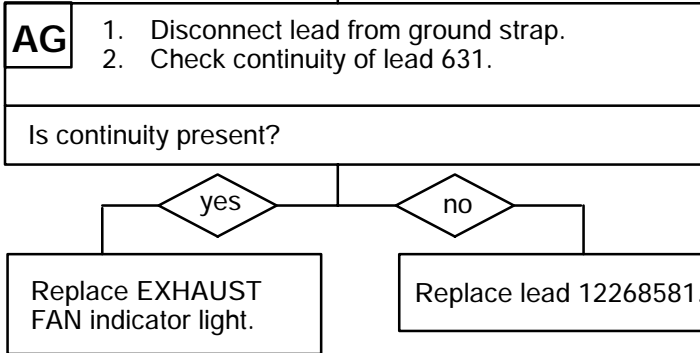

CONTINUED FROM STEP F

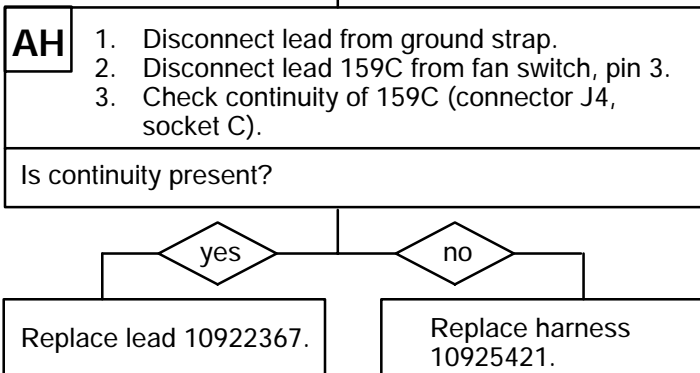

CONTINUED FROM STEP G

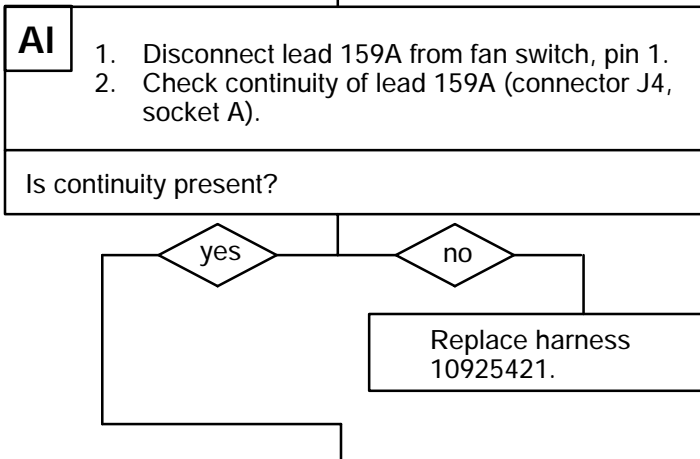

CONTINUED ON NEXT PAGE

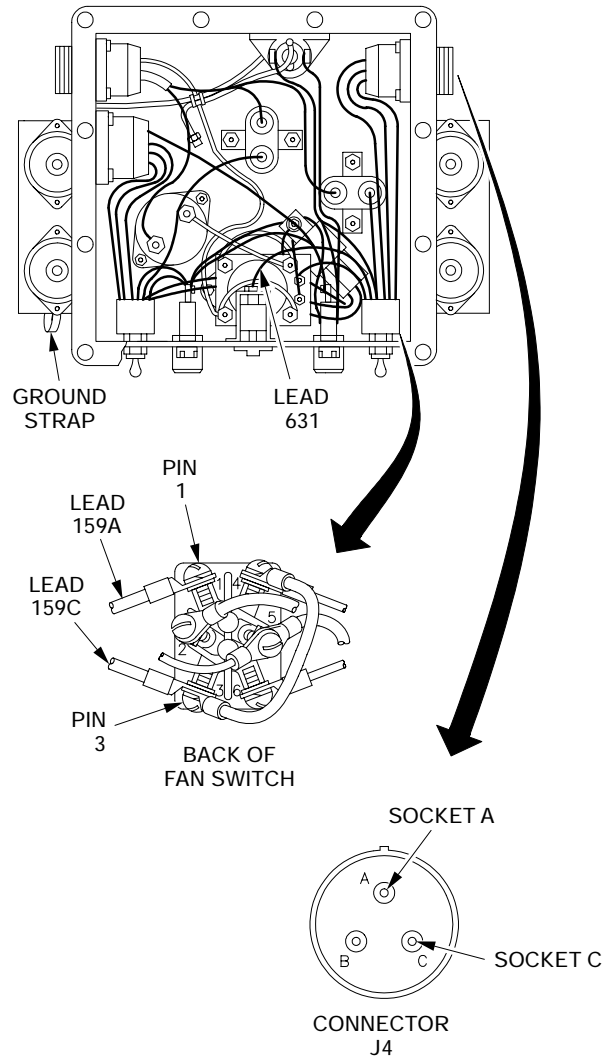

06ph011ta

3-2 TROUBLESHOOTING PROCEDURES - CONTINUED

a.1 ACCESSORY CONTROL BOX (For vehicles with Accessory Control Box P/N 12268547) - CONTINUED

CONTINUED FROM STEP AI

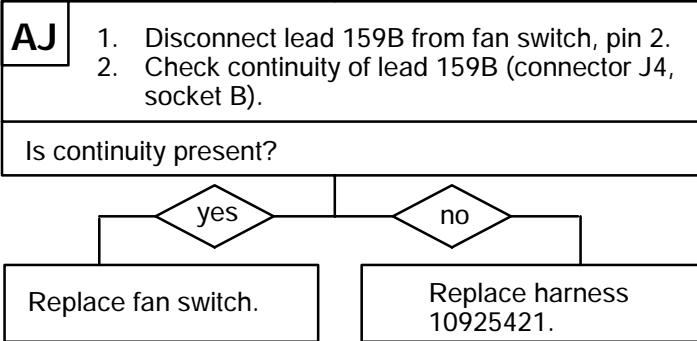

CONTINUED FROM STEP H

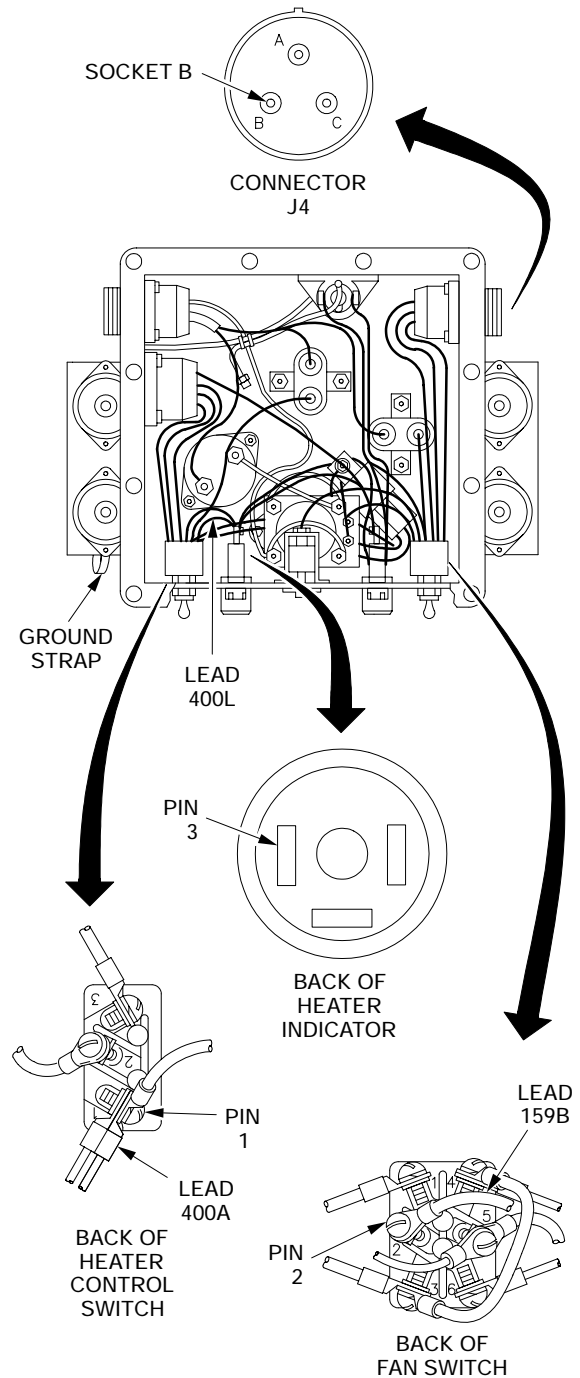
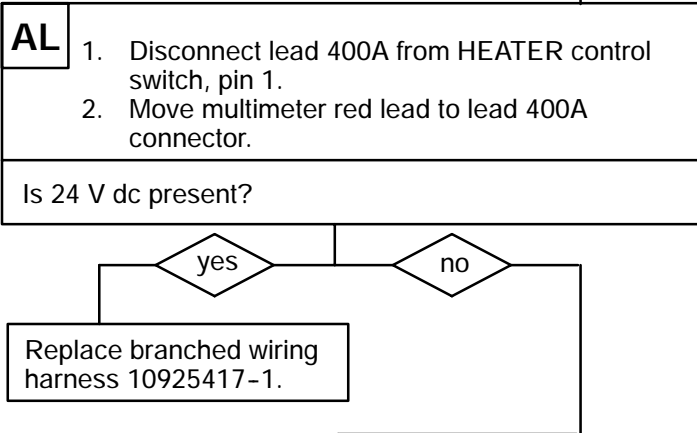
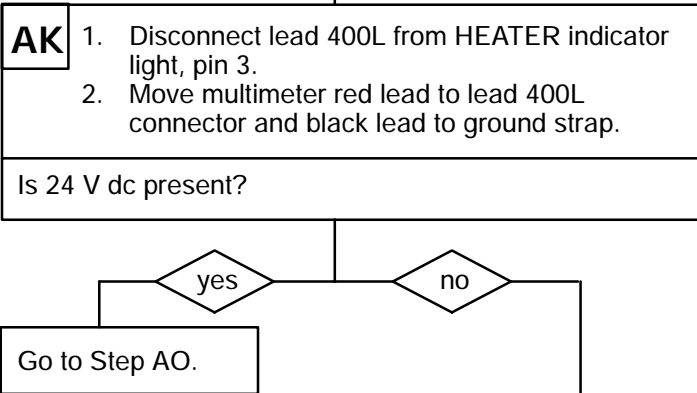

06ph012ta

CONTINUED ON NEXT PAGE

3-2 TROUBLESHOOTING PROCEDURES - CONTINUED

a.1 ACCESSORY CONTROL BOX (For vehicles with Accessory Control Box P/N 12268547) - CONTINUED

CONTINUED FROM STEP AL

AM

1. Reconnect lead 400L to HEATER indicator light, pin 3.
2. Disconnect lead 400A from circuit breaker CB3, pin 2.
3. Move multimeter red lead to CB3, pin 2.

Is 24 V dc present?

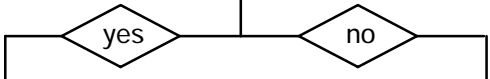

Replace lead 10930337-1.

AN

1. Reconnect lead 400A to HEATER control switch, pin 1.
2. Disconnect lead 10A from circuit breaker CB3, pin 1.
3. Move multimeter red lead to 10A connector.

Is 24 V dc present?

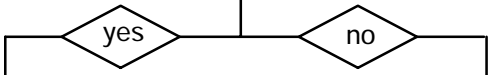

Replace circuit breaker CB3.

Replace harness 12268589.

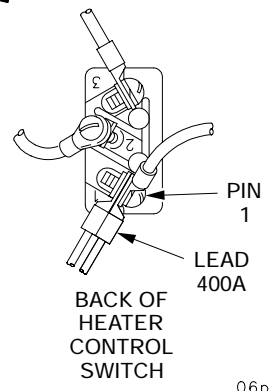
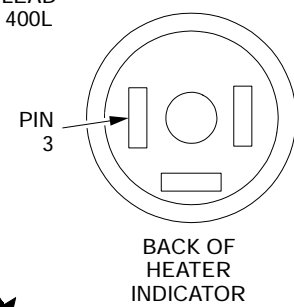
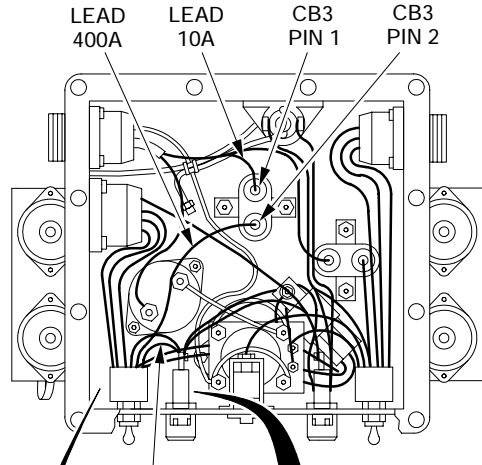

06ph013ta

3-2 TROUBLESHOOTING PROCEDURES - CONTINUED

a.1 ACCESSORY CONTROL BOX (For vehicles with Accessory Control Box P/N 12268547) - CONTINUED

CONTINUED FROM STEP AK

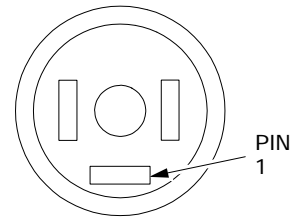
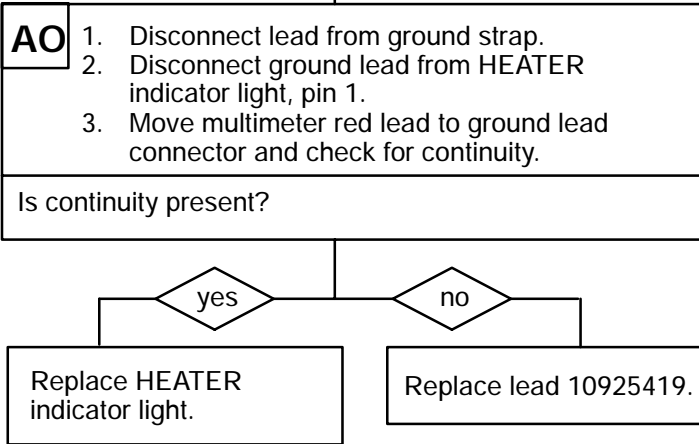

BACK OF HEATER INDICATOR LIGHT

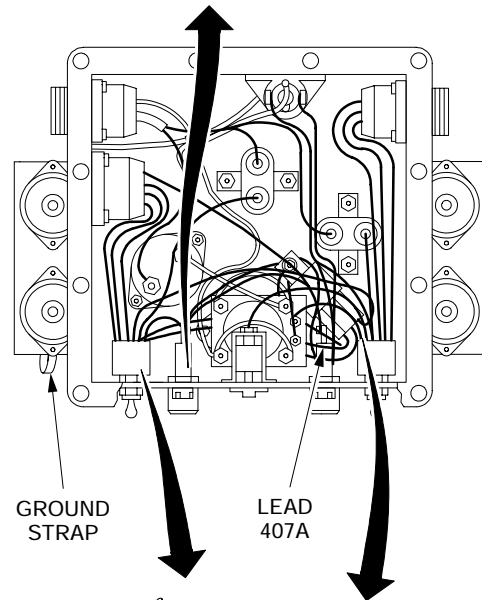

CONTINUED FROM STEP I

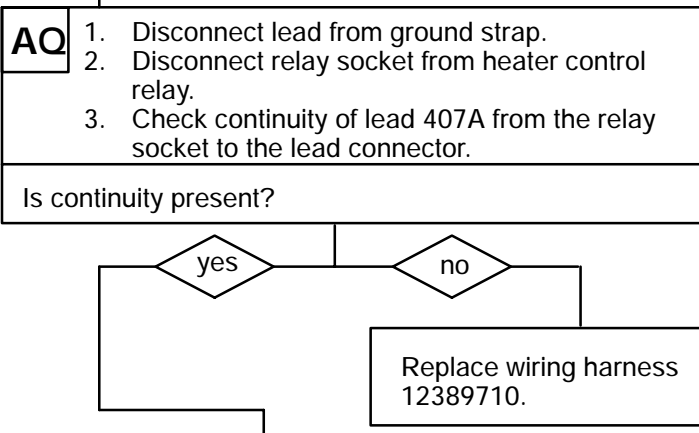
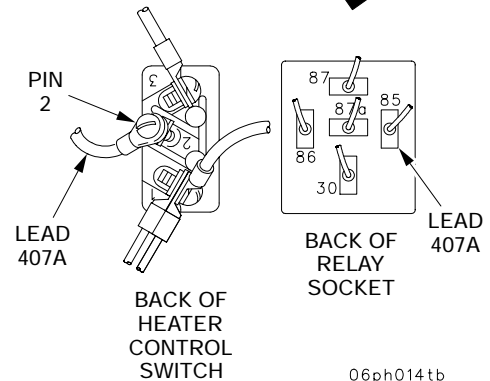
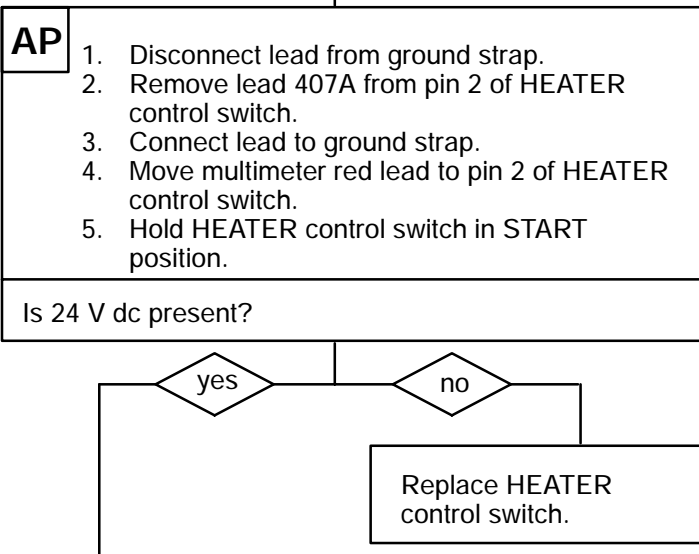

CONTINUED ON NEXT PAGE

3-2 TROUBLESHOOTING PROCEDURES - CONTINUED

a.1 ACCESSORY CONTROL BOX (For vehicles with Accessory Control Box P/N 12268547) - CONTINUED

CONTINUED FROM STEP AO

AR

1. Reconnect lead 407A to pin 2 of HEATER control switch.
2. Disconnect lead 400B at pin 1 of HEATER control switch.
3. Check continuity of lead 400B from the relay socket to the lead connector.

Is continuity present?

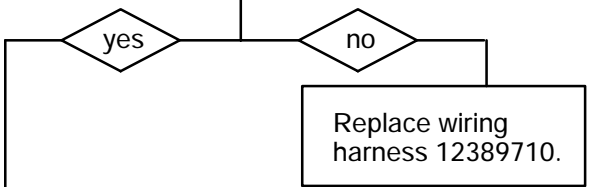

AS

1. Reconnect lead 400B to pin 1 of HEATER control switch.
2. Check continuity of GND lead from the relay socket to the ground strap.

Is continuity present?

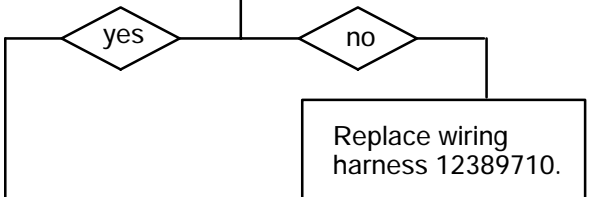

CONTINUED ON NEXT PAGE

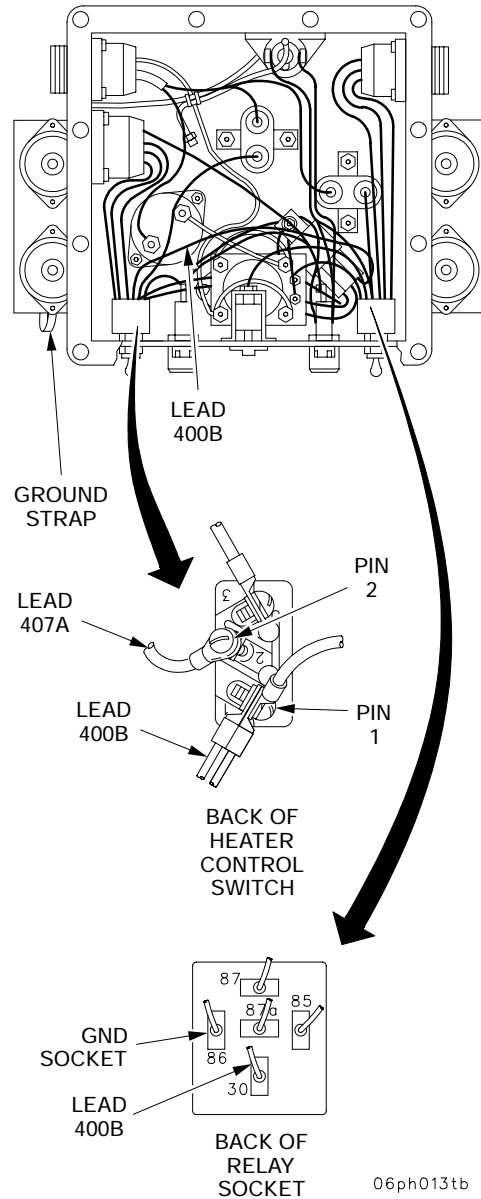

3-2 TROUBLESHOOTING PROCEDURES - CONTINUED

a.1 ACCESSORY CONTROL BOX (For vehicles with Accessory Control Box P/N 12268547) - CONTINUED

CONTINUED FROM STEP AS

AT Check continuity of lead 402 from the relay socket to connector J3, socket C.

Is continuity present?

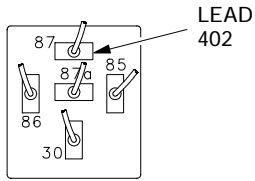
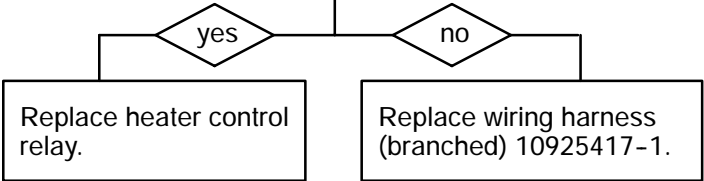

BACK OF RELAY SOCKET
HEATER CONTROL SWITCH

CONTINUED FROM STEP J

AU Move multimeter red lead to pin 3 of the HEATER control switch.

Is 24 V dc present?

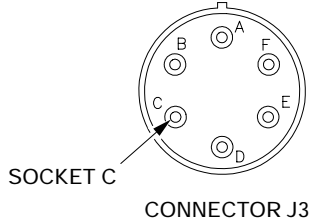
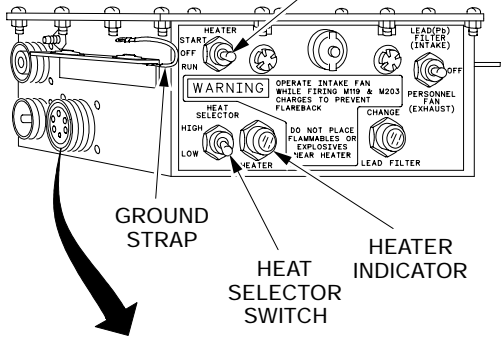
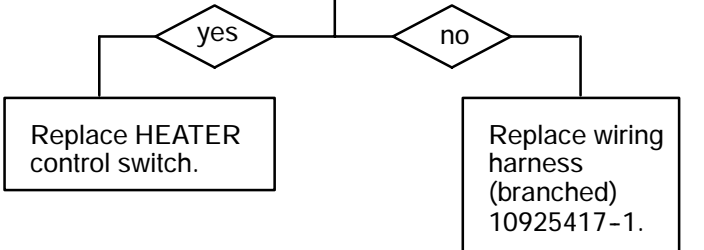

CONTINUED FROM STEP M

AV Move multimeter red lead to pin 2 of the HEAT SELECTOR switch.

Is 24 V dc present?

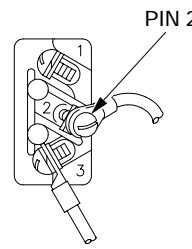
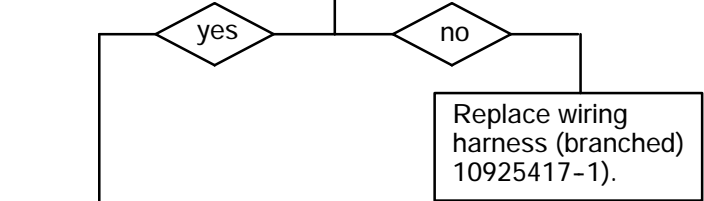

BACK OF HEAT SELECTOR SWITCH

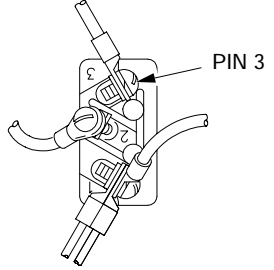

BACK OF HEATER CONTROL SWITCH

06ph013tc

CONTINUED ON NEXT PAGE

3-2 TROUBLESHOOTING PROCEDURES - CONTINUED

a.1 ACCESSORY CONTROL BOX (For vehicles with Accessory Control Box P/N 12268547) - CONTINUED

CONTINUED FROM STEP AV

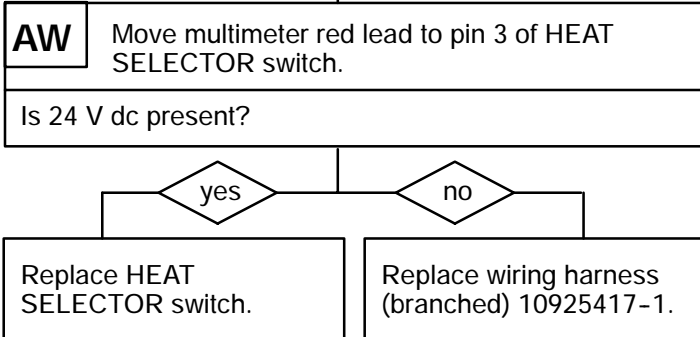

CONTINUED FROM STEP K

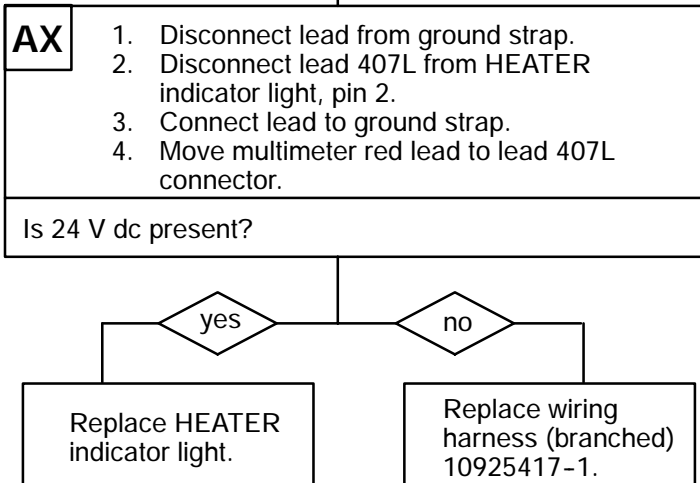

CONTINUED FROM STEP N

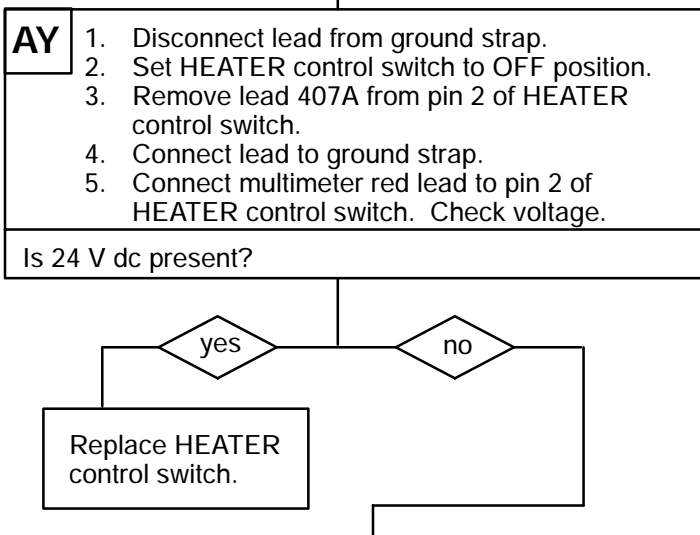

CONTINUED ON NEXT PAGE

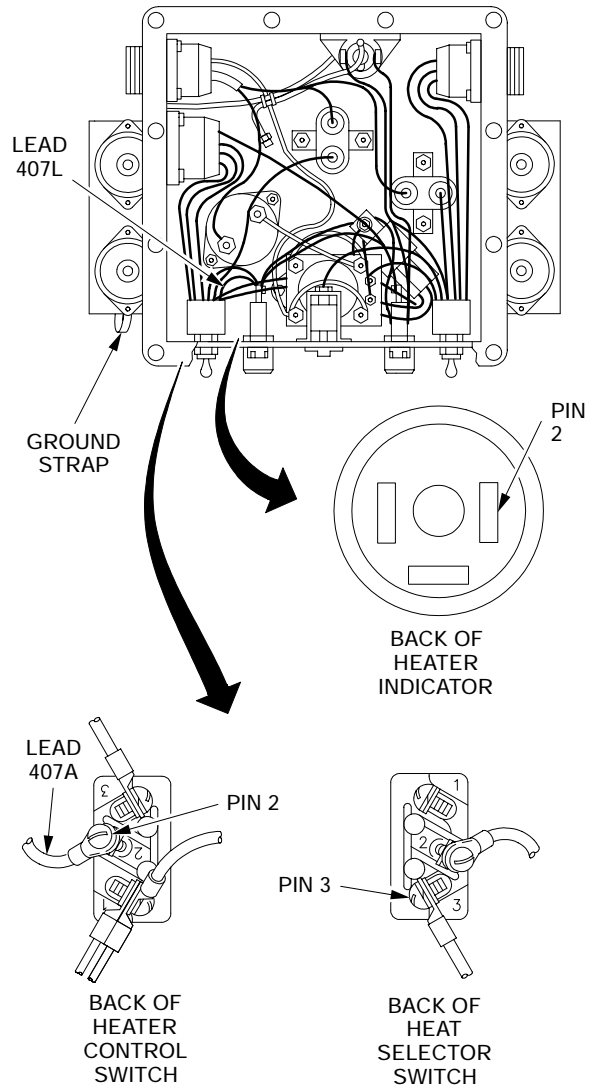

06ph013td

3-2 TROUBLESHOOTING PROCEDURES - CONTINUED

a.1 ACCESSORY CONTROL BOX (For vehicles with Accessory Control Box P/N 12268547) - CONTINUED

CONTINUED FROM STEP AY

- AZ**
1. Disconnect lead from ground strap.
 2. Reconnect lead 407A to pin 2 of HEATER control switch.
 3. Connect lead to ground strap.
 4. Move multimeter red lead to connector J3 socket C. Check voltage.

Is 24 V dc present?



Replace HEATER control relay.

- BA**
1. Move second positive power supply lead from connector J3, socket F to socket D.

Do both panel lights illuminate?



No faults found.

- BB**
1. Disconnect lead from ground strap.
 2. Check continuity of lead 40 between J3, socket D and each of the panel lights.

Is continuity present?

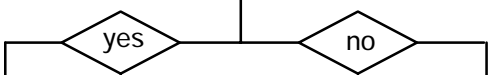

Replace unlit panel light.

Replace wiring harness (branched) 10925417-1.

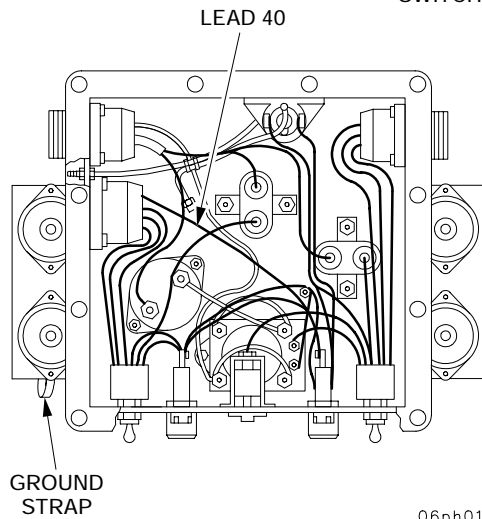
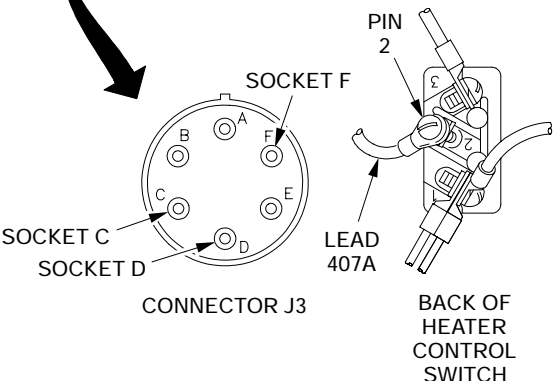
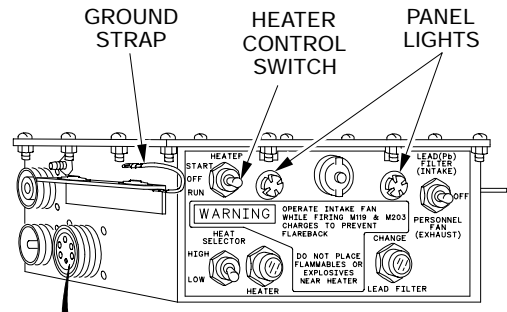

06ph013te

END OF TASK

3-2 TROUBLESHOOTING PROCEDURES - CONTINUED

b. AIR CLEANER BLOWER MOTORS

The air cleaner blower motor consists of a capacitor and motor assembly. 24 V dc is applied through the capacitor to the motor's stator windings causing the armature to rotate, thus spinning the impeller to push air.

INITIAL SETUP	
<u>Tools</u> Fuel and electrical tool kit (SC 5180-95-B08) Multimeter (item 31, Appx F) Probe kit (item 27, Appx F)	<u>Equipment Conditions</u> Motor cover removed (para 5-1)

WARNING

Be careful when working with live circuits. Jewelry should be removed prior to working with live circuits. Failure to do this may result in personnel injury - electrical shock.

NOTE

Refer to paragraph 5-1 for all repair procedures.

1. Connect power source negative lead to air cleaner blower motor ground lead and positive lead to air cleaner blower motor positive lead.
2. Disconnect capacitor electrical lead from motor lead connector.
3. Connect multimeter red lead to capacitor electrical lead and black lead on ground.
4. Monitor voltage.

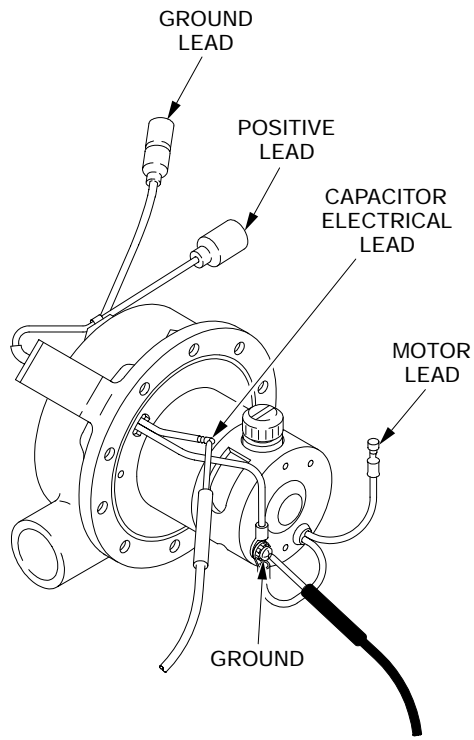
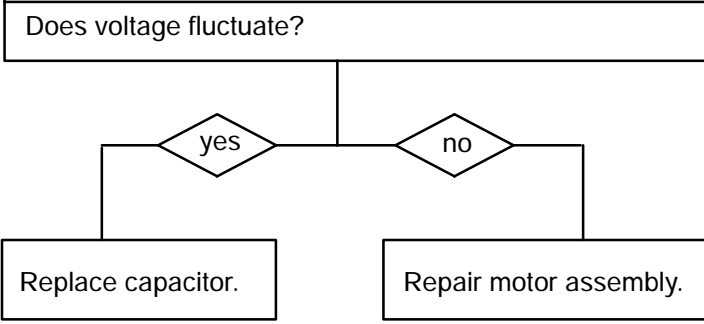

03ph001t

END OF TASK

3-2 TROUBLESHOOTING PROCEDURES - CONTINUED

c. CREW COMPARTMENT WARNING LIGHT AND ENCLOSURE

The crew compartment warning light and enclosure consists of an indicator light, two diodes, connector, and associated wiring. The relationship of these components is shown below. In the vehicle, the crew compartment warning light is connected in parallel with the master warning light and provides the cab crew with master warning indications.

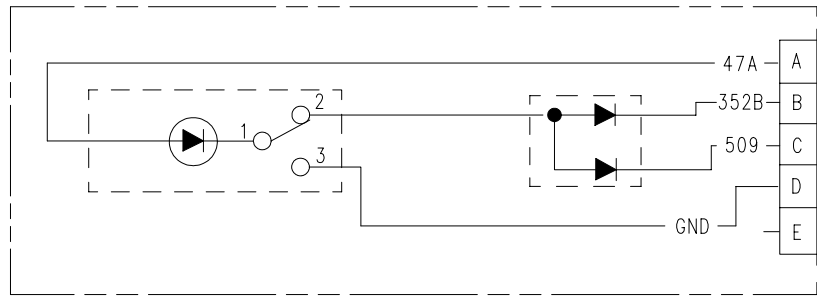

06ph016t

<u>INITIAL SETUP</u>	
<p><u>Tools</u></p> <ul style="list-style-type: none"> Fuel and electrical tool kit (SC 5180-95-B08) Multimeter (item 31, Appx F) Probe kit (item 27, Appx F) 	<p><u>Equipment Conditions</u></p> <ul style="list-style-type: none"> Enclosure cover removed (para 7-4)

WARNING

Be careful when working with live circuits. Jewelry should be removed prior to working with live circuits. Failure to do this may result in personnel injury - electrical shock.

3-2 TROUBLESHOOTING PROCEDURES - CONTINUED

c. CREW COMPARTMENT WARNING LIGHT AND ENCLOSURE - CONTINUED

NOTE
Refer to paragraph 7-4 for all repair procedures.

A Place multimeter red lead on point 1, black lead on point 2, and verify continuity.

<u>Point 1</u>	<u>Point 2</u>
<u>Front connector</u>	<u>Back connector</u>
Pin A	Pin A
Pin B	Pin B
Pin C	Pin C
Pin D	Pin D

Is continuity present?

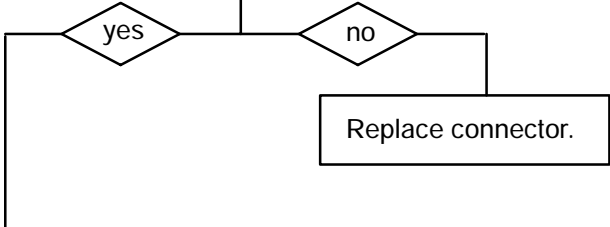

B Place multimeter red lead on connector pin A and black lead on indicator light pin 1.

Is continuity present?

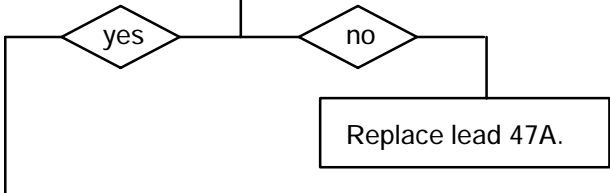

C Place multimeter red lead on connector pin D and black lead on indicator light pin 3.

Is continuity present?

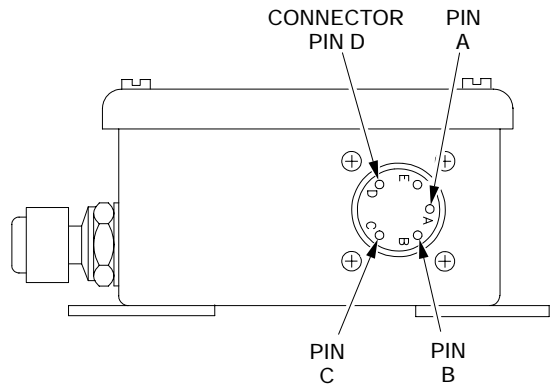
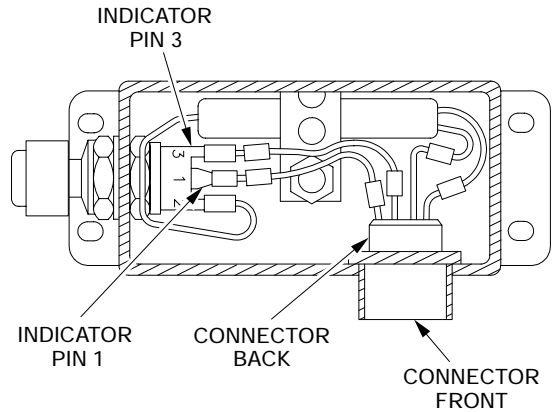
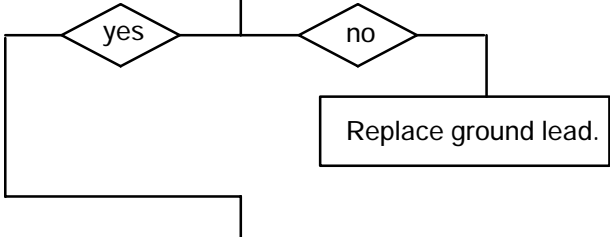

06ph017t

CONTINUED ON NEXT PAGE

3-2 TROUBLESHOOTING PROCEDURES - CONTINUED

c. CREW COMPARTMENT WARNING LIGHT AND ENCLOSURE - CONTINUED

CONTINUED FROM STEP C

D	<ol style="list-style-type: none"> 1. Connect power supply ground lead to connector pin D. 2. Connect power supply positive lead to connector pin A. 3. Press PRESS-TO-TEST indicator.
Does indicator light illuminate?	

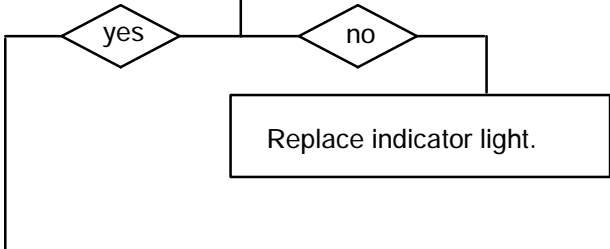

E	Remove power supply ground lead from connector pin D and connect it to connector pin C, then pin B.
Does indicator light illuminate both times?	

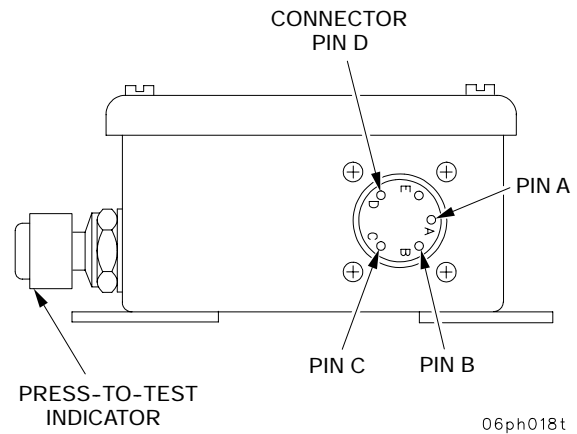
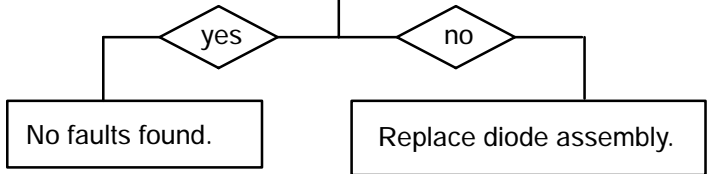

06ph018t

END OF TASK

3-2 TROUBLESHOOTING PROCEDURES - CONTINUED

d. GUN TUBE TRAVEL LOCK CONTROL BOX

The gun tube travel lock control box consists of three indicator lights, two toggle switches, a relay, a cable assembly with two diodes, and associated wiring. The relationship of these components is shown below. In the vehicle, the gun tube travel lock control box controls the raising/lowering and locking/unlocking of the gun tube travel lock.

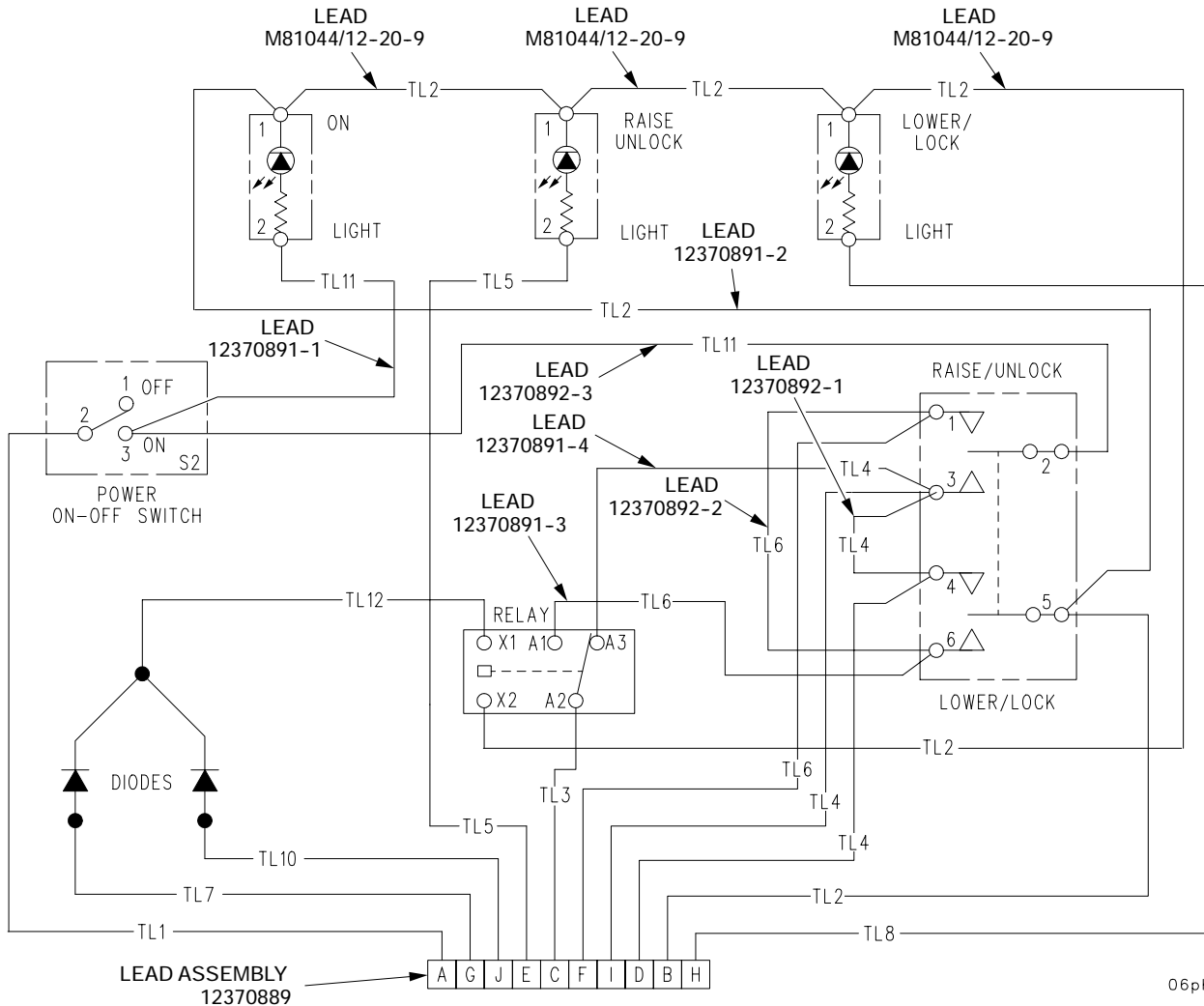

06ph019t

3-2 TROUBLESHOOTING PROCEDURES - CONTINUED

d. GUN TUBE TRAVEL LOCK CONTROL BOX - CONTINUED

INITIAL SETUP

Tools

Fuel and electrical tool kit
(SC 5180-95-B08)
Multimeter (item 31, Appx F)
Probe kit (item 27, Appx F)

Equipment Conditions

Gun tube travel lock control box cover removed (para 7-2)

WARNING

Be careful when working with live circuits. Jewelry should be removed prior to working with live circuits. Failure to do this may result in personnel injury - electrical shock.

NOTE

Refer to paragraph 7-2 for all repair procedures.

A Connect multimeter red lead to relay pin X1 and black lead to connector pin G, then to connector pin J.

Is continuity present?

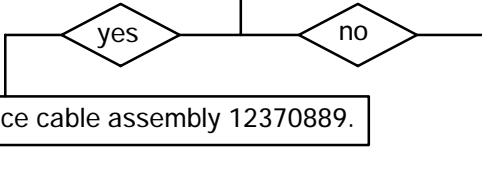

B Connect multimeter red lead to point 1, black lead to point 2, verify continuity.

<u>Point 1</u>	<u>Point 2</u>
Connector pin A	POWER switch pin 2
pin B	RAISE/LOWER switch pin 5
pin C	Relay pin A2
pin D	RAISE/LOWER switch pin 4
pin E	RAISE/UNLOCK indicator pin 2
pin F	RAISE/LOWER switch pin 1
pin H	LOWER/LOCK indicator pin 2
pin I	RAISE/LOWER switch pin 3

Is continuity present?

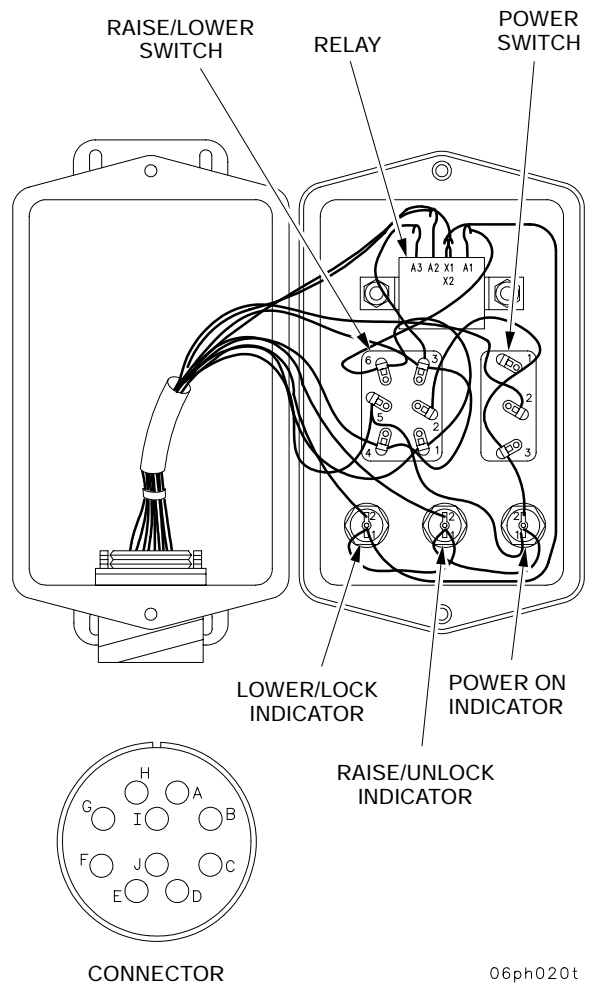
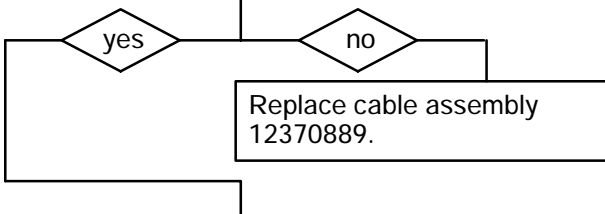

CONTINUED ON NEXT PAGE

06ph020t

3-2 TROUBLESHOOTING PROCEDURES - CONTINUED

d. GUN TUBE TRAVEL LOCK CONTROL BOX - CONTINUED

CONTINUED FROM STEP B

C Connect multimeter red lead to point 1, black lead to point 2, verify continuity.

<u>Point 1</u>	<u>Point 2</u>
Connector pin G	Relay pin X1
Connector pin J	Relay pin X1

Is continuity present?

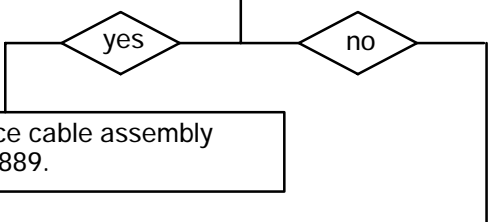

D Place multimeter red lead on POWER switch pin 3 and black lead on ON indicator light pin 2.

Is continuity present?

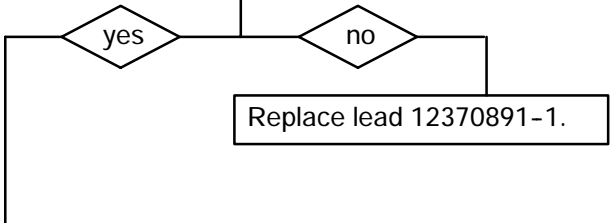

E Move multimeter black lead to RAISE/LOWER switch pin 2.

Is continuity present?

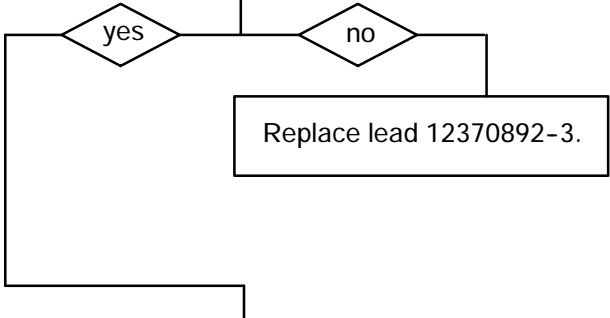

CONTINUED ON NEXT PAGE

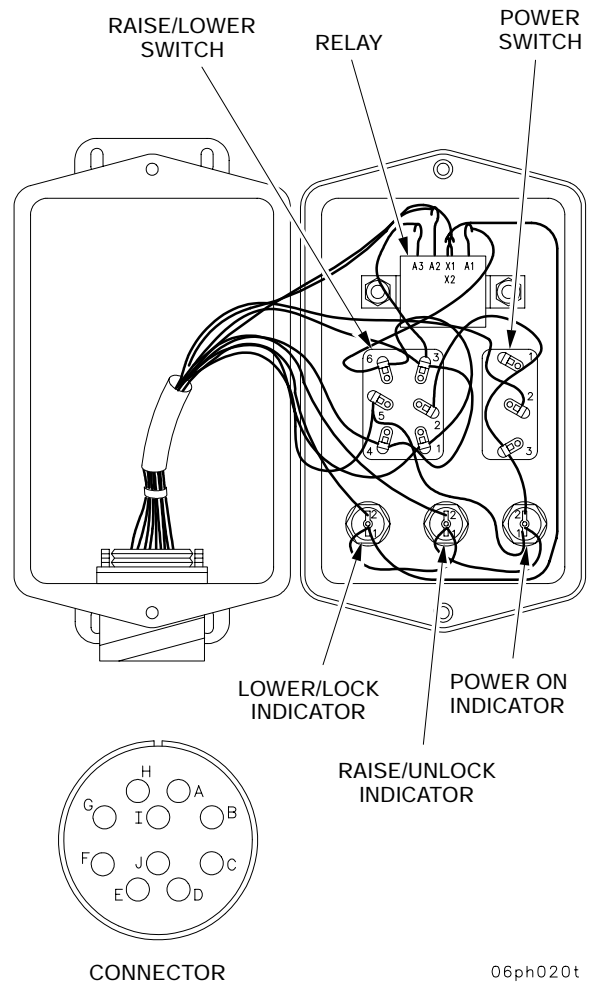

06ph020t

3-2 TROUBLESHOOTING PROCEDURES - CONTINUED

d. GUN TUBE TRAVEL LOCK CONTROL BOX - CONTINUED

CONTINUED FROM STEP E

F Place multimeter red lead on RAISE/LOWER switch pin 5 and black lead on ON indicator light pin 1.
Is continuity present?

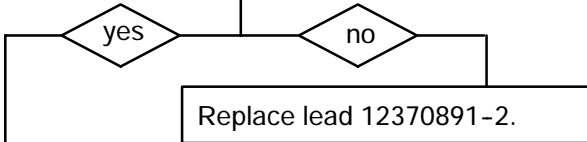

G Move multimeter red lead to RAISE/UNLOCK indicator light pin 1.
Is continuity present?

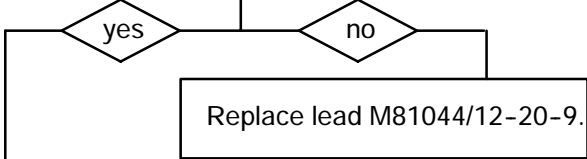

H Move multimeter black lead to LOWER/LOCK indicator light pin 1.
Is continuity present?

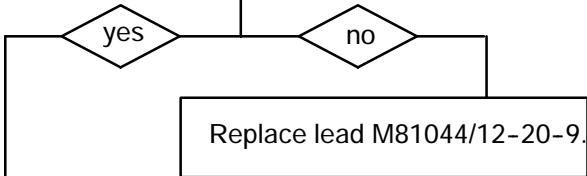

I Move multimeter red lead to relay pin X2.
Is continuity present?

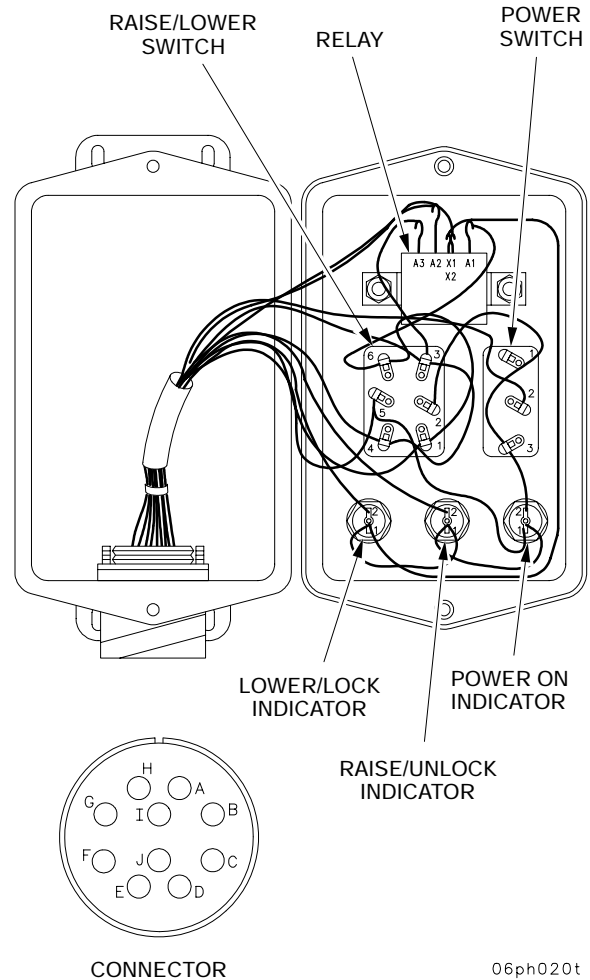
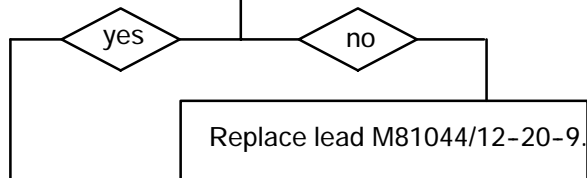

CONTINUED ON NEXT PAGE

06ph020t

3-2 TROUBLESHOOTING PROCEDURES - CONTINUED

d. GUN TUBE TRAVEL LOCK CONTROL BOX - CONTINUED

CONTINUED FROM STEP I

J Place multimeter red lead on relay pin A1 and black lead on RAISE/LOWER switch pin 6.
Is continuity present?

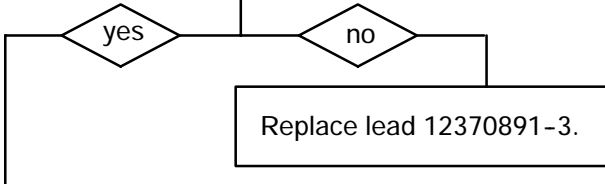

K Move multimeter red lead to RAISE/LOWER switch pin 1.
Is continuity present?

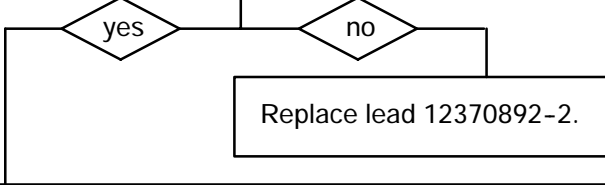

L Place multimeter red lead on RAISE/LOWER switch pin 3 and black lead on pin 4.
Is continuity present?

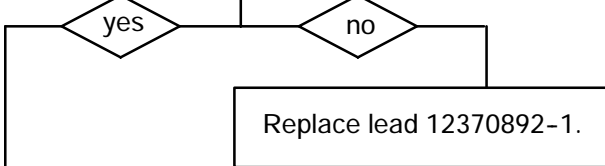

M Move multimeter black lead to relay pin A3.
Is continuity present?

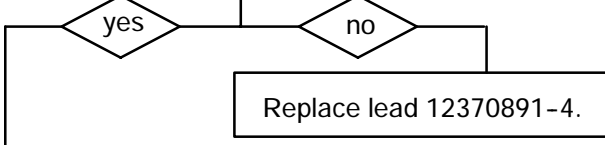

CONTINUED ON NEXT PAGE

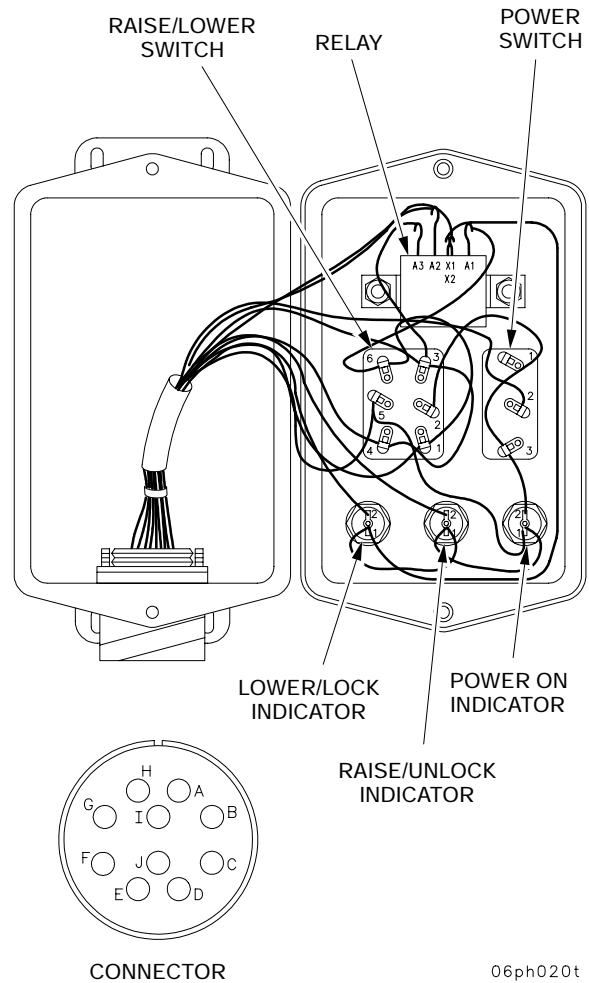

06ph020t

3-2 TROUBLESHOOTING PROCEDURES - CONTINUED

d. GUN TUBE TRAVEL LOCK CONTROL BOX - CONTINUED

CONTINUED FROM STEP M

N

1. Check operation of the POWER switch by placing multimeter red lead on point 1, black lead on point 2, and switch in indicated position.
2. Verify the following table.

Point 1	Point 2	Switch Position	Continuity
POWER switch			
Pin 2	Pin1	ON	NO
Pin 2	Pin1	OFF	YES

Does POWER switch function properly?

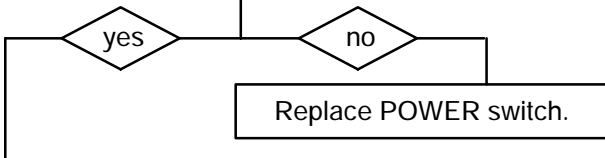

O

1. Check operation of the RAISE/LOWER switch by placing multimeter red lead on point 1, black lead on point 2, and switch in indicated position.
2. Verify the following table.

Point 1	Point 2	Switch Position	Continuity
2	1	OFF	NO
2	3	OFF	NO
1	3	OFF	NO
5	4	OFF	NO
5	6	OFF	NO
4	6	OFF	NO
2	1	RAISE/UNLOCK	YES
2	3	RAISE/UNLOCK	NO
5	4	RAISE/UNLOCK	YES
5	6	RAISE/UNLOCK	NO
2	1	LOWER/LOCK	NO
2	3	LOWER/LOCK	YES
5	4	LOWER/LOCK	NO
5	6	LOWER/LOCK	YES

Does RAISE/LOWER switch function properly?

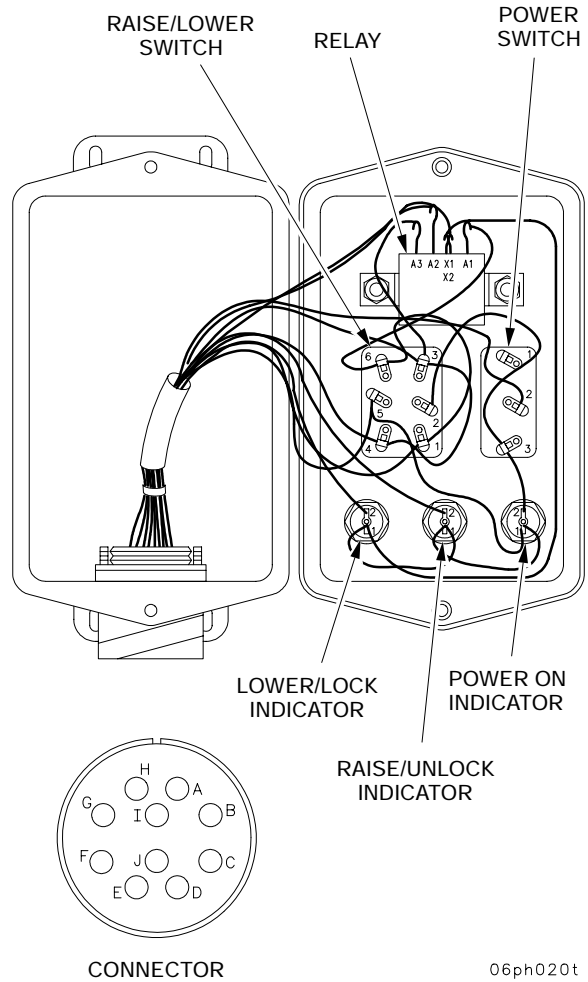
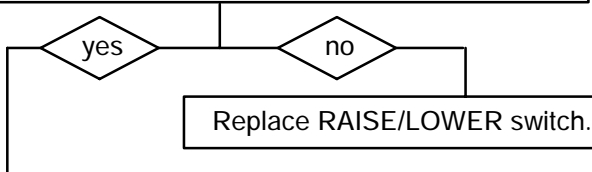

06ph020t

CONTINUED ON NEXT PAGE

3-2 TROUBLESHOOTING PROCEDURES - CONTINUED

d. GUN TUBE TRAVEL LOCK CONTROL BOX - CONTINUED

CONTINUED FROM STEP O

P Place multimeter red lead on relay pin A2 and black lead on pin A1.

Is an open circuit indicated?

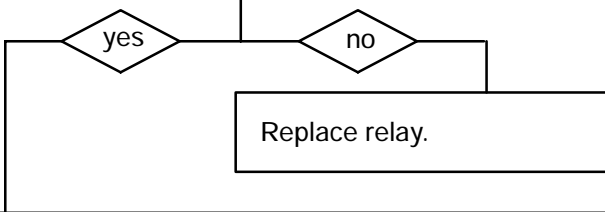

Q 1. Connect power supply ground lead to connector pin B and power supply positive lead to connector pin J.
2. Check continuity between relay pins A1 and A2.

Is continuity present?

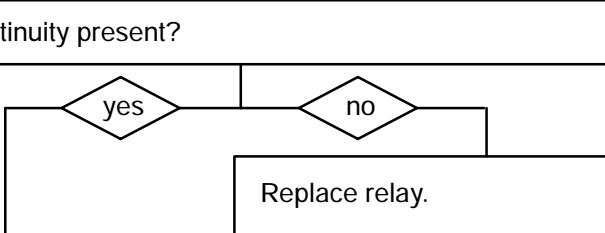

R Move power supply positive lead from connector pin J to pin H.

Does LOWER/LOCK indicator light illuminate?

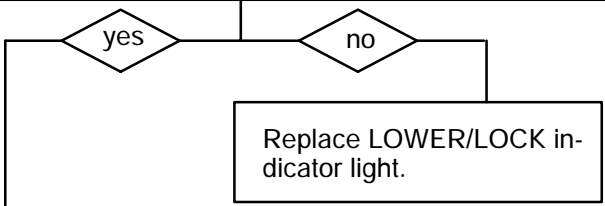

CONTINUED ON NEXT PAGE

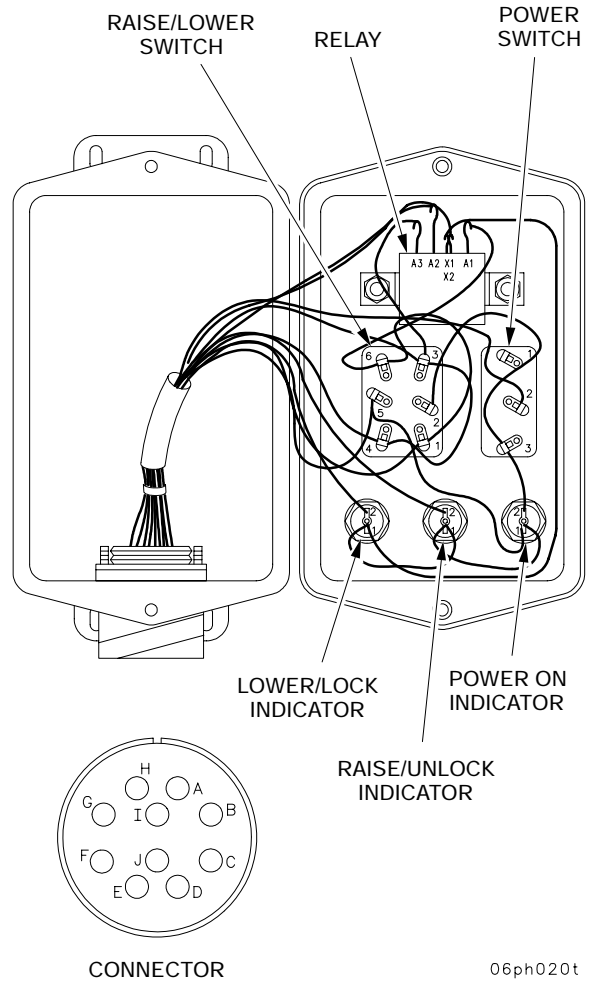

06ph020t

3-2 TROUBLESHOOTING PROCEDURES - CONTINUED

d. GUN TUBE TRAVEL LOCK CONTROL BOX - CONTINUED

CONTINUED FROM STEP R

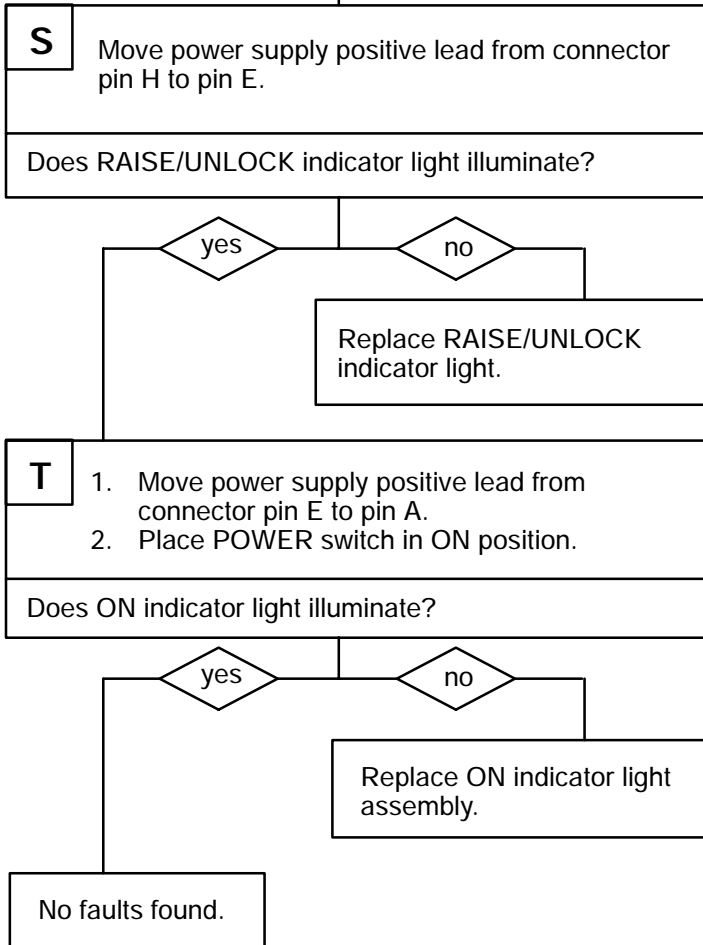

END OF TASK

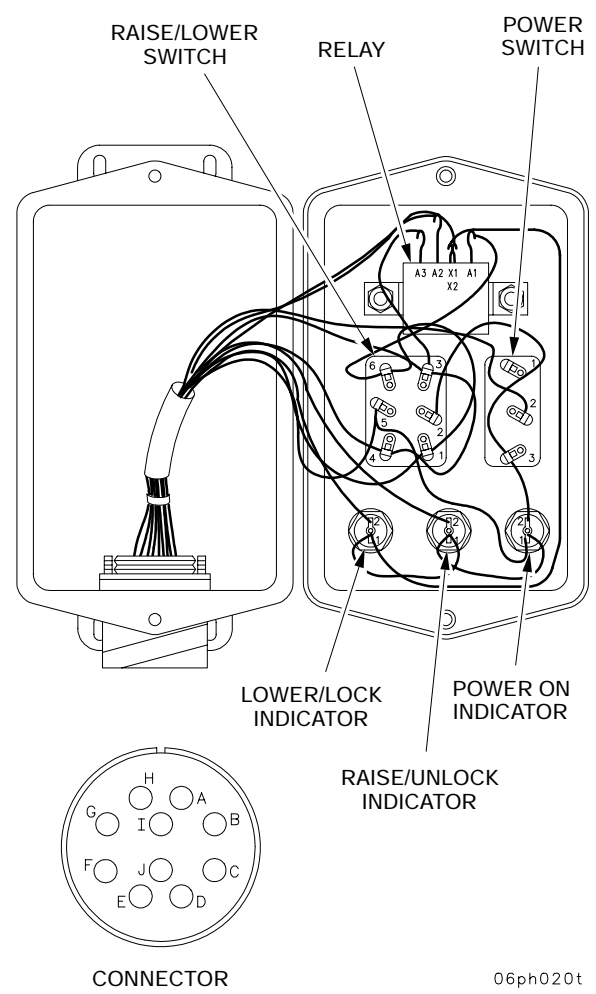

06ph020t

3-2 TROUBLESHOOTING PROCEDURES - CONTINUED

e. VOLTAGE REGULATOR CONTROL BOX

The voltage regulator control box consists of a circuit breaker, relay, indicator light, and associated wiring. The relationship of these components is shown below.

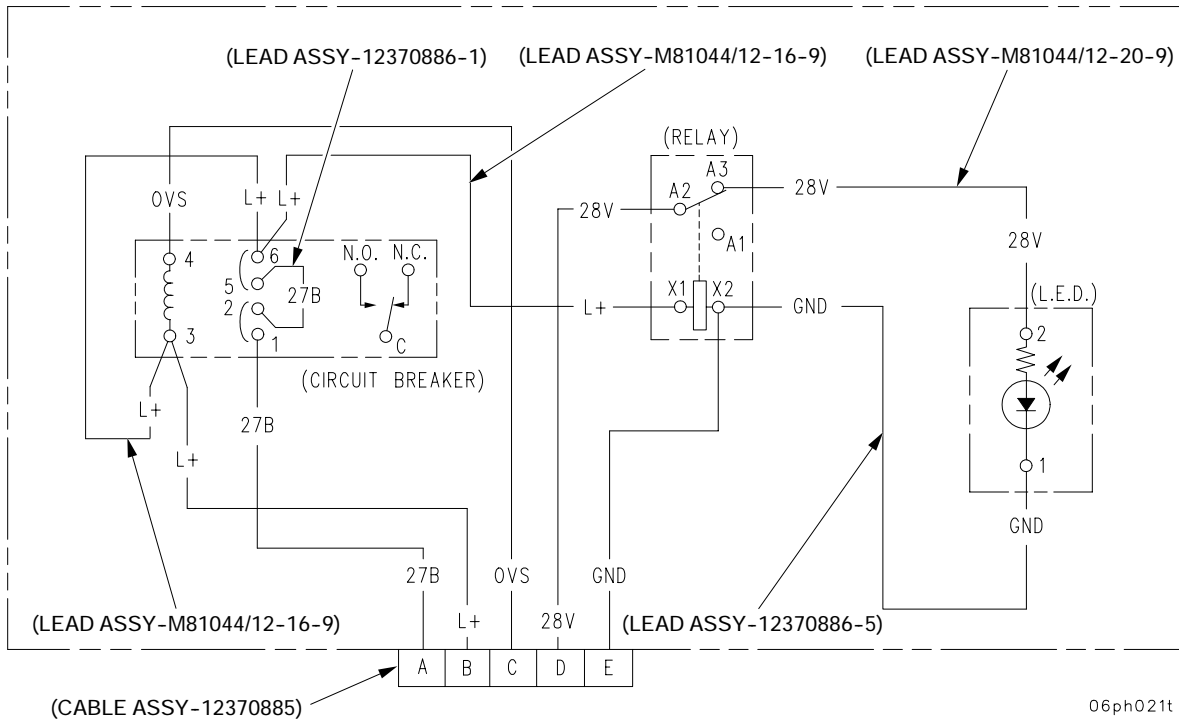

06ph021t

INITIAL SETUP

Tools

- Fuel and electrical tool kit (SC 5180-95-B08)
- Multimeter (item 31, Appx F)
- Probe kit (item 27, Appx F)

Equipment Conditions

- Voltage regulator control box cover removed (para 7-3)

WARNING

Be careful when working with live circuits. Jewelry should be removed prior to working with live circuits. Failure to do this may result in personnel injury - electrical shock.

3-2 TROUBLESHOOTING PROCEDURES - CONTINUED

e. VOLTAGE REGULATOR CONTROL BOX - CONTINUED

NOTE
Refer to paragraph 7-3 for all repair procedures.

- A** Place multimeter red lead on point 1, black lead on point 2, and verify continuity.
- | | |
|-----------------|-----------------------|
| <u>Point 1</u> | <u>Point 2</u> |
| Connector pin A | Circuit breaker pin 1 |
| Connector pin B | Circuit breaker pin 3 |
| Connector pin C | Circuit breaker pin 4 |
| Connector pin D | Relay pin A2 |
| Connector pin E | Relay pin X2 |

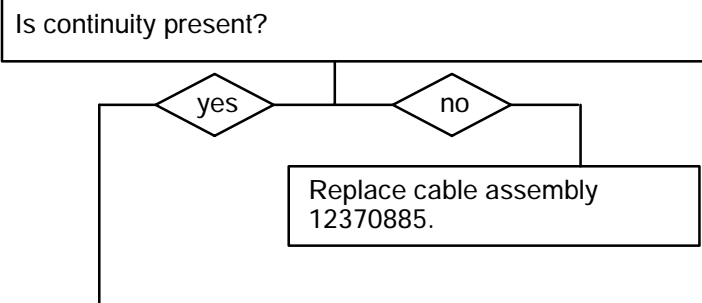

- B** Place multimeter red lead on circuit breaker pin 6 and black lead on pin 3.

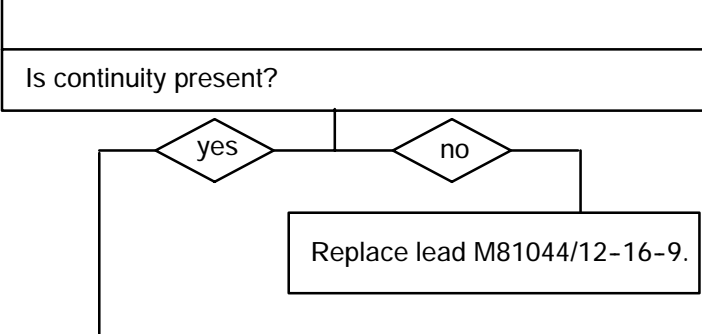

- C** Move multimeter black lead to relay pin X1.

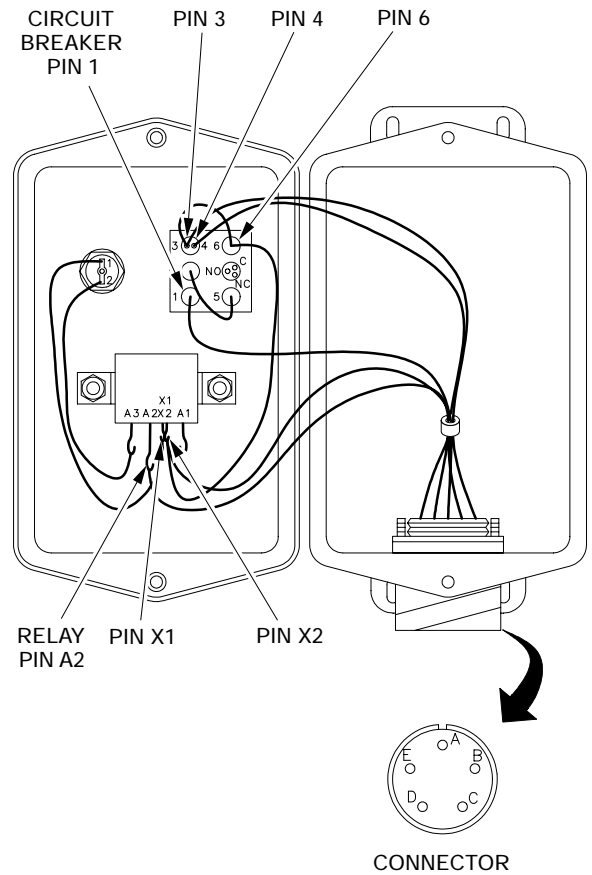
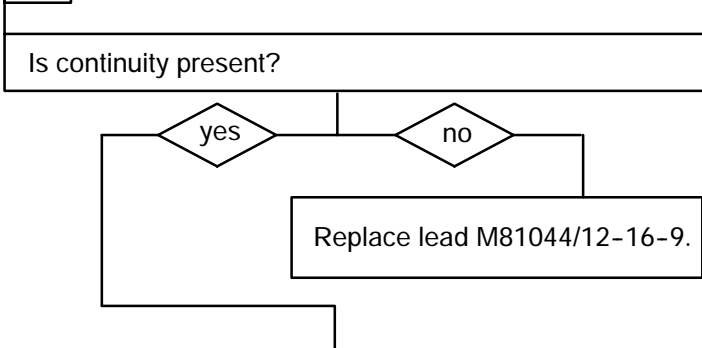

06ph022t

CONTINUED ON NEXT PAGE

3-2 TROUBLESHOOTING PROCEDURES - CONTINUED

e. VOLTAGE REGULATOR CONTROL BOX - CONTINUED

CONTINUED FROM STEP C

D Place multimeter red lead on relay pin X2 and black lead on indicator light pin 1.
Is continuity present?

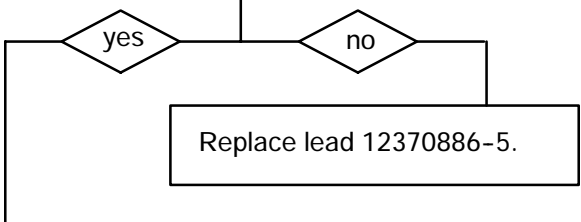

E Place multimeter red lead on relay pin A3 and black lead on indicator light pin 2.
Is continuity present?

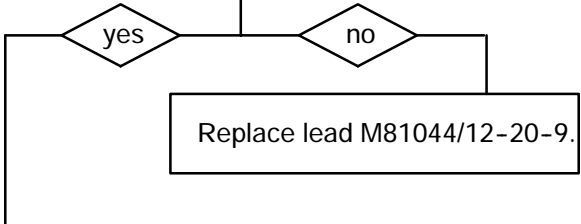

F Place multimeter red lead on circuit breaker pin 2 and black lead on pin 5.
Is continuity present?

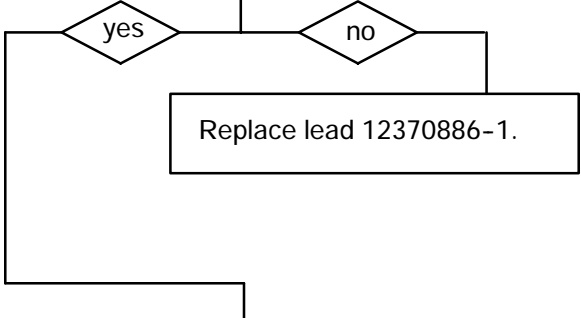

CONTINUED ON NEXT PAGE

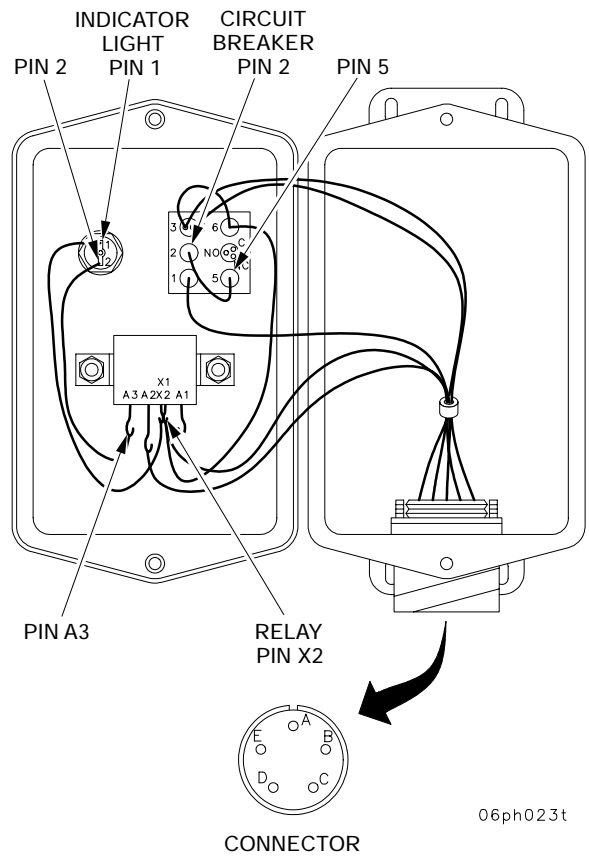

3-2 TROUBLESHOOTING PROCEDURES - CONTINUED

e. VOLTAGE REGULATOR CONTROL BOX - CONTINUED

CONTINUED FROM STEP F

G Place multimeter red lead on point 1, black lead on point 2, and verify the following table.

Point 1	Point 2	Circuit Breaker Position	Continuity
Circuit breaker			
Pin 3	Pin 4		YES
Pin 1	Pin 6	OFF	NO
Pin 1	Pin 6	ON	YES

Does circuit breaker function properly?

yes | no

Replace circuit breaker.

H Connect power supply ground lead to connector pin E and positive lead to connector pin D.

Does indicator light illuminate?

yes | no

Replace indicator light.

I

1. Connect a second lead from power supply positive to connector pin A.
2. Place CIRCUIT BREAKER switch in ON position and observe indicator light.

Does indicator light go out?

yes | no

No faults found. | Replace relay.

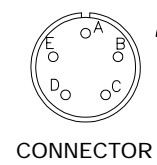
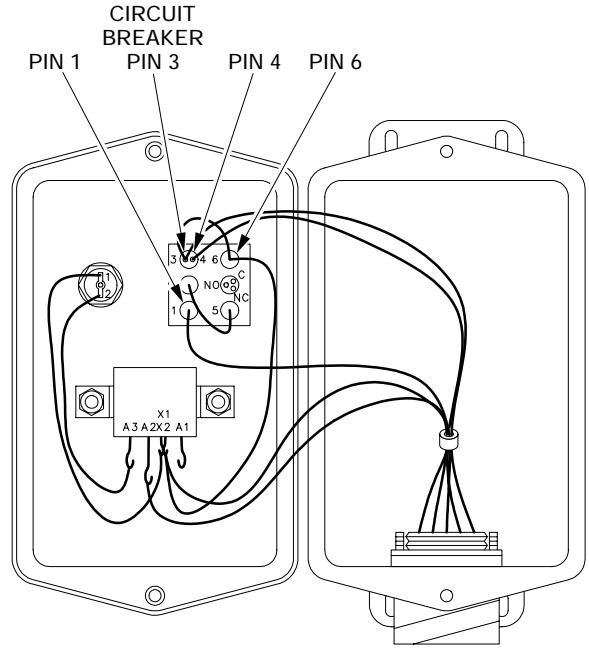

06ph024t

END OF TASK

3-2 TROUBLESHOOTING PROCEDURES - CONTINUED

f. WINTERIZATION COOLANT HEATER CONTROL BOX

The coolant heater control box consists of a circuit breaker, two toggle switches, an indicator light, and associated wiring. The relationship of these components is shown below. In the vehicle, the coolant heater control box controls the operation of the coolant heater in the winterization kit.

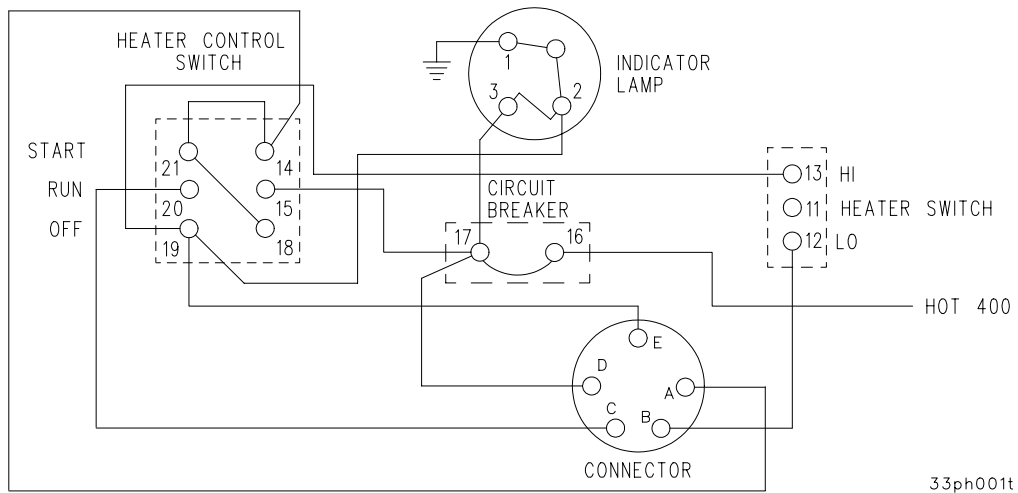

INITIAL SETUP	
<p><u>Tools</u></p> <p>Fuel and electrical tool kit (SC 5180-95-B08)</p> <p>Multimeter (item 31, Appx F)</p> <p>Probe kit (item 27, Appx F)</p>	<p><u>Equipment Conditions</u></p> <p>Case and angle bracket removed from coolant heater control box (para 12-5)</p>

WARNING

Be careful when working with live circuits. Jewelry should be removed prior to working with live circuits. Failure to do this may result in personnel injury - electrical shock.

3-2 TROUBLESHOOTING PROCEDURES - CONTINUED

f. WINTERIZATION COOLANT HEATER CONTROL BOX - CONTINUED

NOTE
Refer to paragraph 12-5 for all repair procedures.

A Place multimeter red lead on point 1, black lead on point 2, and check continuity.

Point 1	Point 2
Connector pin A	HEATER CONTROL switch pin 14
pin B	HEAT switch pin 12
pin C	HEATER CONTROL switch pin 20
pin D	Circuit breaker pin 17
pin E	HEATER CONTROL switch pin 19

Is continuity present?

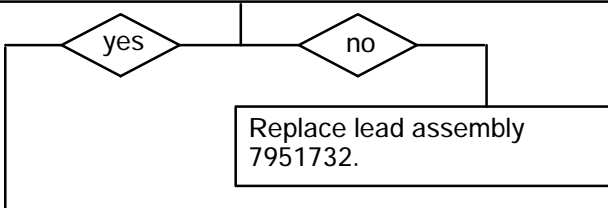

B Connect multimeter leads to each terminal of the circuit breaker.

Is continuity present?

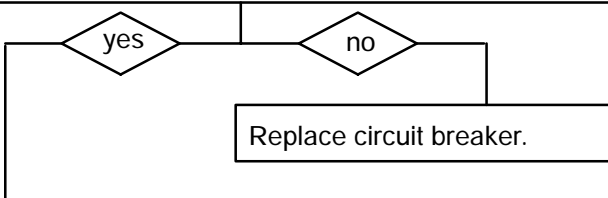

C Connect multimeter red lead to circuit breaker and black lead to lead 7986167 connector.

Is continuity present?

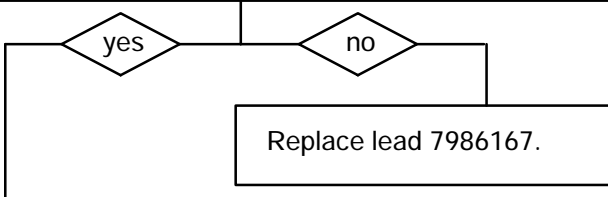

CONTINUED ON NEXT PAGE

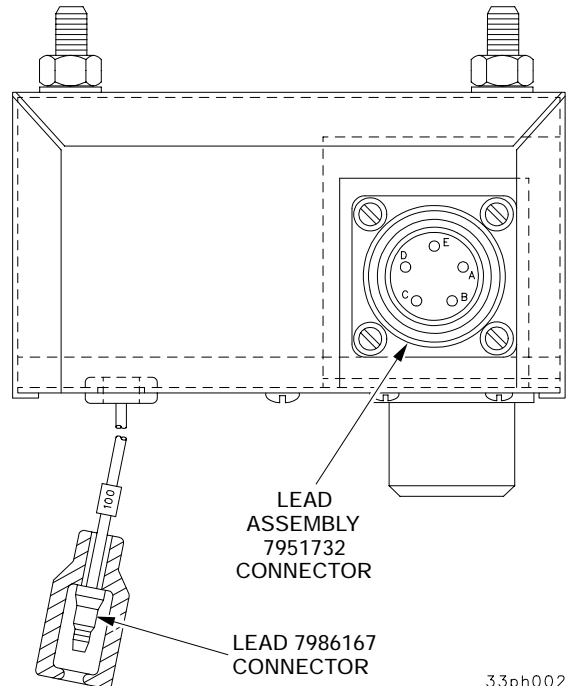
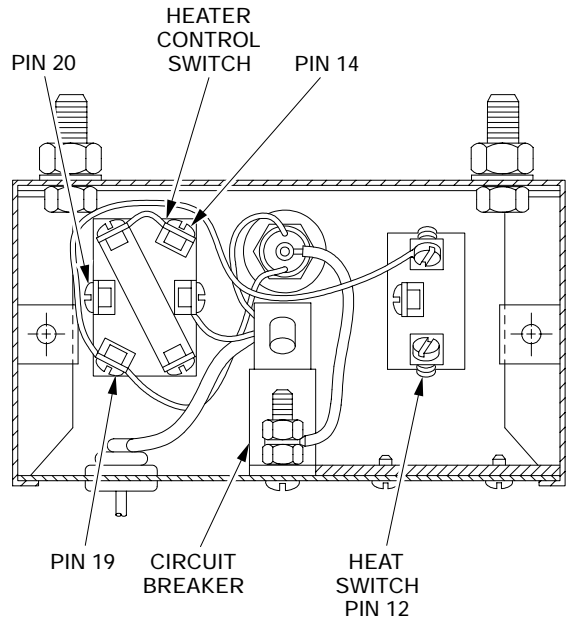

33ph002t

3-2 TROUBLESHOOTING PROCEDURES - CONTINUED

f. WINTERIZATION COOLANT HEATER CONTROL BOX - CONTINUED

CONTINUED FROM STEP C

D Connect multimeter red lead to circuit breaker and black lead to HEATER CONTROL switch pin 15.

Is continuity present?

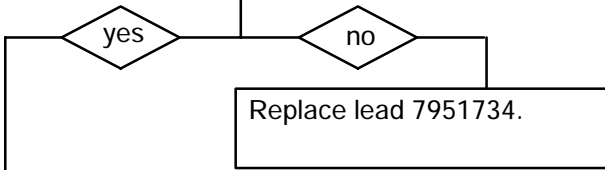

E Place multimeter red lead on HEATER CONTROL switch pin 21 and black lead on pin 14.

Is continuity present?

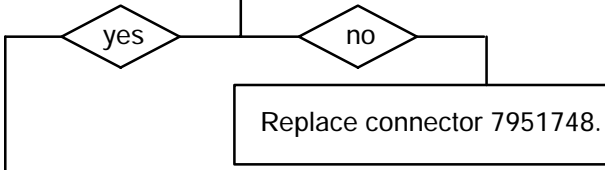

F Place multimeter red lead on HEATER CONTROL switch pin 21 and black lead on pin 16.

Is continuity present?

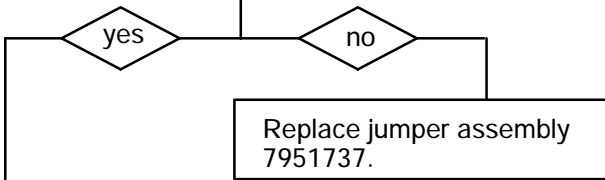

G Place multimeter red lead on HEAT switch pin 13 and black lead on HEATER CONTROL switch pin 19.

Is continuity present?

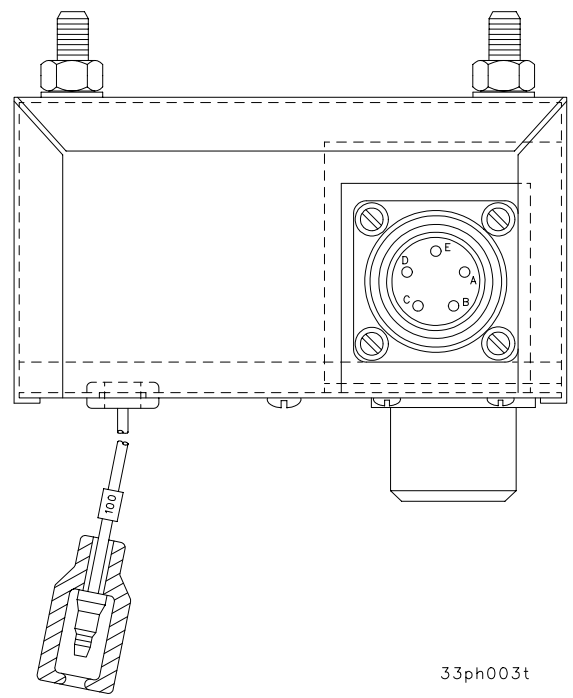
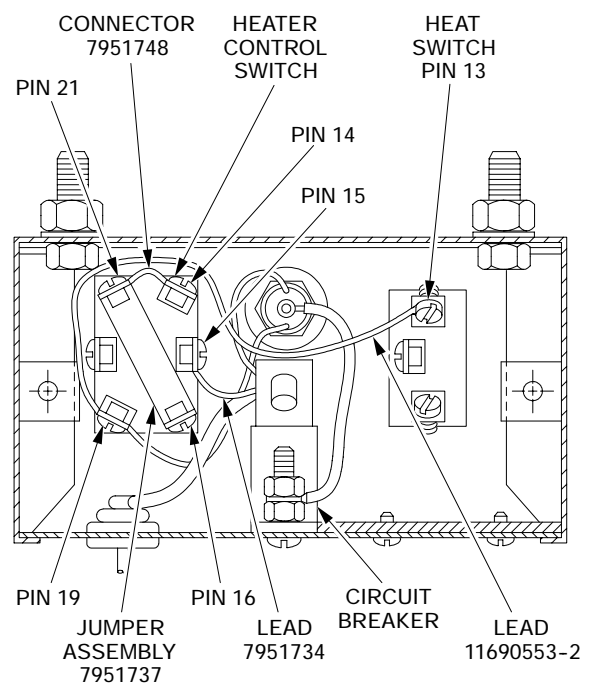
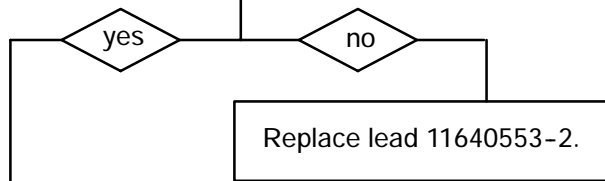

33ph003t

3-2 TROUBLESHOOTING PROCEDURES - CONTINUED

f. WINTERIZATION COOLANT HEATER CONTROL BOX - CONTINUED

CONTINUED FROM STEP G

H Place multimeter red lead on point 1, black lead on point 2, and verify continuity.

<u>Point 1</u>	<u>Point 2</u>
Indicator Lamp Assembly 7951731	
Pin 1	Ground stud
Pin 2	HEATER CONTROL switch pin 19
Pin 3	Circuit breaker

Is continuity present?

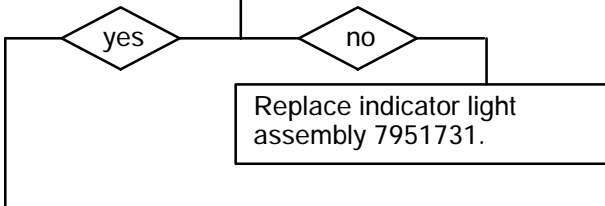

I Check operation of HEAT switch by placing HEAT switch in indicated position, multimeter red lead on point 1, black lead on point 2, and verify the table below.

Switch Position	Point 1	Point 2	Continuity
HI	Pin 11	Pin 12	No
HI	Pin 11	Pin 13	Yes
LO	Pin 11	Pin 12	Yes
LO	Pin 11	Pin 13	No

Does switch function properly?

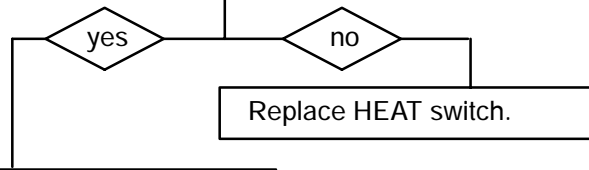

CONTINUED ON NEXT PAGE

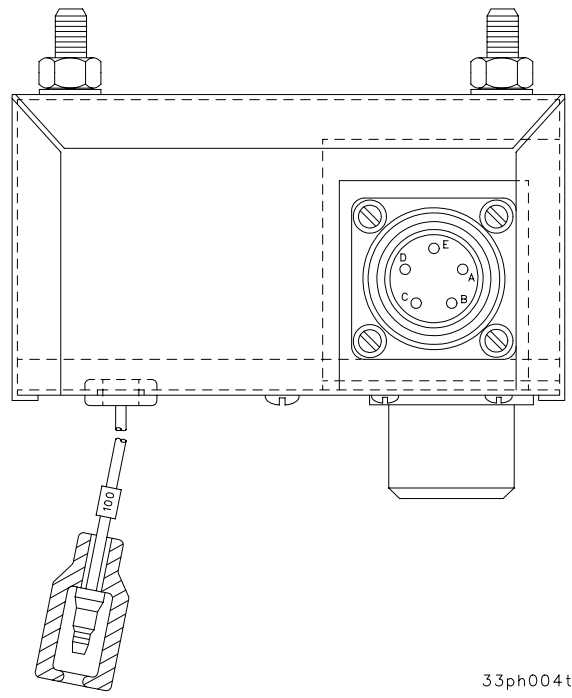
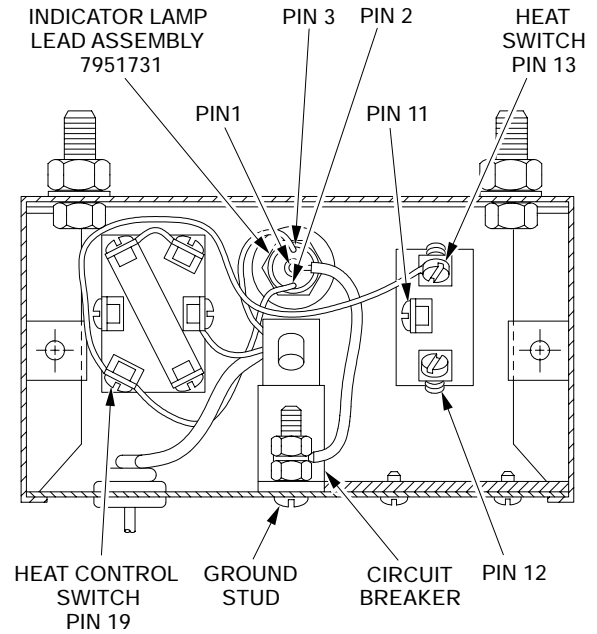

33ph004t

3-2 TROUBLESHOOTING PROCEDURES - CONTINUED

f. WINTERIZATION COOLANT HEATER CONTROL BOX - CONTINUED

CONTINUED FROM STEP I

J Check operation of HEATER CONTROL switch by placing switch in indicated position, multimeter red lead on point 1, black lead on point 2, and verify the table below.

Switch Position	Point 1	Point 2	Continuity
OFF	Pin 15	Pin 14	No
OFF	Pin 15	Pin 18	No
OFF	Pin 20	Pin 19	No
OFF	Pin 20	Pin 21	No
RUN	Pin 15	Pin 14	No
RUN	Pin 15	Pin 18	Yes
RUN	Pin 20	Pin 19	No
RUN	Pin 20	Pin 21	Yes
START	Pin 15	Pin 14	Yes
START	Pin 15	Pin 18	No
START	Pin 20	Pin 19	Yes
START	Pin 20	Pin 21	No

Does switch function properly?

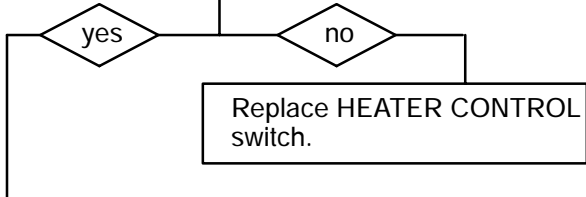

K

1. Connect power supply ground lead to ground stud and positive lead to lead 7986167 connector.
2. Press indicator lamp.

Does indicator light illuminate?

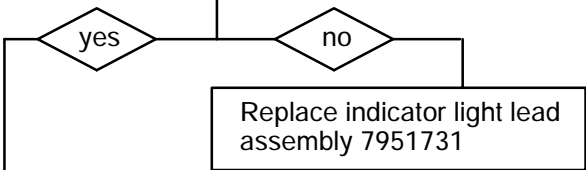

No faults found.

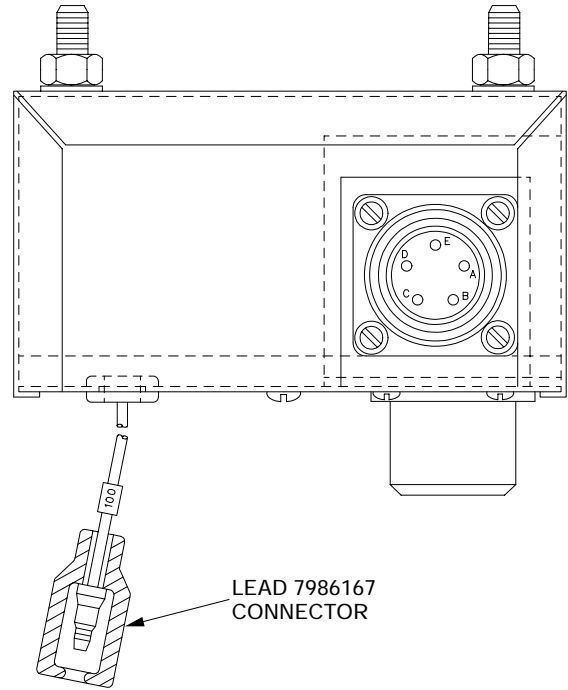
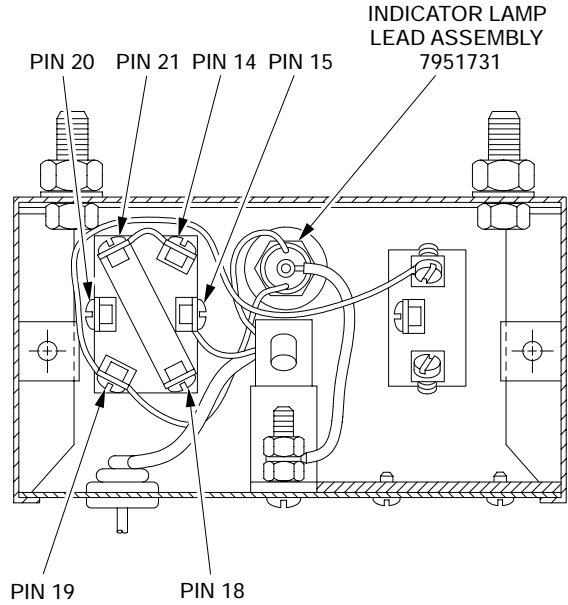

END OF TASK

CHAPTER 4 POWERPACK

GENERAL

This chapter illustrates and describes direct support maintenance procedures for the powerpack, engine assembly, and drive components.

This chapter also identifies components and accessories of unserviceable repairable engine that are required to return to the overhaul depot with the engine.

<u>CONTENTS</u>	<u>Page</u>
Section I. POWERPACK	
4-1 REMOVAL AND INSTALLATION OF ENGINE AND TRANSMISSION-RELATED COMPONENTS	4-2
4-2 SEPARATION OF ENGINE FROM POWER TRAIN ASSEMBLY	4-7
Section II. ENGINE ASSEMBLY	
4-3 VIBRATION DAMPENER AND ADAPTER	4-13
4-4 MASS RING AND FLEXIBLE COUPLING	4-15
Section III. PREPARATION FOR STORAGE OR SHIPMENT	
4-5 SHIPPING AND STORAGE CONTAINERS, ENGINE PARTS, AND ACCESSORIES LIST	4-17
Section IV. TRANSMISSION TRUNNION CAPS	
4-6 TRANSMISSION TRUNNION REPLACEMENT CAPS	4-21
Section V. FINAL DRIVE ASSEMBLY	
4-7 FINAL DRIVE ASSEMBLY	4-25

Section I. POWERPACK

4-1 REMOVAL AND INSTALLATION OF ENGINE AND TRANSMISSION-RELATED COMPONENTS.

This task covers: a. Preliminary procedures b. Removal c. Installation

INITIAL SETUP

Tools

General mechanic's tool kit
(SC 5180-90-N26)
Engine lifting sling (item 39, Appx F)
Powerpack stand (item 35, Appx F) (fabricated)
Drain pan (item 14, Appx F)
Suitable lifting device

Materials/Parts

Lumber (item 17, Appx B)

Equipment Conditions

Powerpack removed
(TM 9-2350-314-20-1-1)

Personnel Required

Two

References

TM 9-2350-314-10
TM 9-2350-314-20-1-1
TM 9-2350-314-20-1-2
TM 9-2350-314-20-2-2
TM 9-2815-202-34
TM 9-2520-234-35
TM 9-2920-242-35
TM 9-2920-243-34
TM 9-2920-248-35

a. Preliminary procedures.

WARNING

Make sure powerpack is evenly balanced and stable on blocks or stand. Severe injury or equipment damage may result if powerpack falls from supporting device.

- 1 Place powerpack on fabricated stand.

Section I. POWERPACK - CONTINUED

4-1 REMOVAL AND INSTALLATION OF ENGINE AND TRANSMISSION-RELATED COMPONENTS - CONTINUED

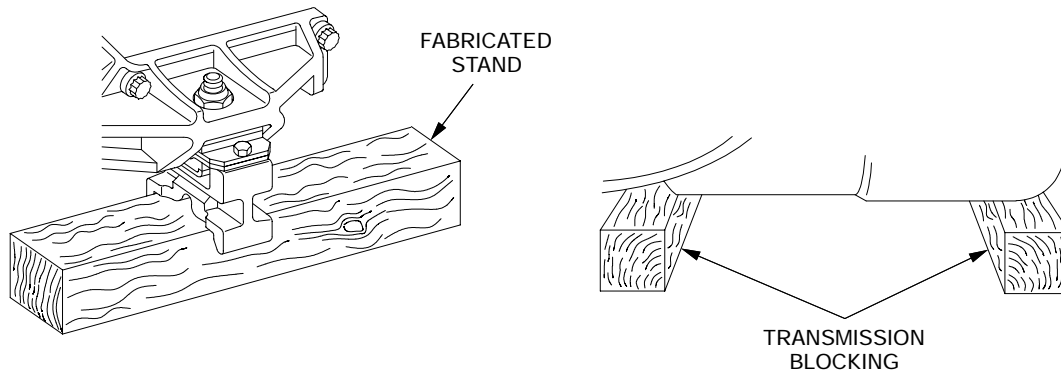
a. Preliminary procedures - Continued

01ph015m

- 2 Drain engine and transmission oil and coolant system (TM 9-2350-314-10).
- 3 Remove radiator and surge tank (TM 9-2350-314-20-1-1).

NOTE

Aeration detector leads are disconnected when shroud is removed.

- 4 Remove radiator shroud and cooling fan assemblies (TM 9-2350-314-20-1-1).
- 5 Remove VMS angle drive adapter (TM 9-2350-314-20-1-1).
- 6 Remove VMS assembly, VMS bracket, and VMS shaft assembly (TM 9-2350-314-20-2-2).

NOTE

ADDITIONAL REPAIR AND MAINTENANCE DATA

For repair or maintenance, which is not discussed in this manual, refer to:

- TM 9-2815-202-34 for Detroit Diesel GMC Series 8V71T diesel engine
- TM 9-2520-234-35 for Allison GMC Model XTG-411-2A/-4 transmission
- TM 9-2920-248-35 for Prestolite starter
- TM 9-2920-242-35 for Delco-Remy starter
- TM 9-2920-243-34 for Leece-Neville starter

Section I. POWERPACK - CONTINUED

4-1 REMOVAL AND INSTALLATION OF ENGINE AND TRANSMISSION-RELATED COMPONENTS - CONTINUED

a. Preliminary procedures - Continued

NOTE

These procedures are general in nature. Some steps may not be required to remove or replace a particular component.

b. Removal.

- 1 Remove sending units and protective covers (TM 9-2350-314-20-1-2).
- 2 Remove speedometer and tachometer cables, adapters, and brackets (TM 9-2350-314-20-1-2).
- 3 Remove required transmission and brake linkage (TM 9-2350-314-20-1-2).
- 4 Remove transmission hubs (TM 9-2350-314-20-1-2).
- 5 Remove oil analysis system from oil filters and transmission (TM 9-2350-314-20-1-1).
- 6 Remove oil filters, lines, and hoses (TM 9-2350-314-20-1-1).
- 7 Remove wiring harnesses and clamps (TM 9-2350-314-20-1-2).
- 8 Remove engine wiring harness mounting bracket (TM 9-2350-314-20-1-2).
- 9 Remove primary and secondary fuel filters, clamps, lines, and hoses (TM 9-2350-314-20-1-1).
- 10 Remove coolant tubes, hoses, and clamps (TM 9-2350-314-20-1-1).
- 11 To separate engine from power train assembly, refer to paragraph 4-2.
- 12 To separate transfer from engine and transmission, follow procedures of paragraph 4-2, then refer to TM 9-2520-234-35.
- 13 To separate transmission from engine and transfer, follow procedures of paragraph 4-2, then refer to TM 9-2520-234-35.

Section I. POWERPACK - CONTINUED

4-1 REMOVAL AND INSTALLATION OF ENGINE AND TRANSMISSION-RELATED COMPONENTS - CONTINUED

c. Installation.**NOTE**

The following instructions will complete the engine assembly process performed in paragraph 4-2. After following these procedures, the powerpack will be ready to install in the vehicle.

- 1 Install coolant tubes, hoses, and clamps (TM 9-2350-314-20-1-1).
- 2 Install primary and secondary fuel filters, clamps, lines, and hoses (TM 9-2350-314-20-1-1).
- 3 Install engine wiring harness mounting bracket (TM 9-2350-314-20-1-2).
- 4 Install wiring harnesses and clamps (TM 9-2350-314-20-1-2).
- 5 Install oil filters, lines, and hoses (TM 9-2350-314-20-1-1).
- 6 Install oil analysis system on oil filters and transmission (TM 9-2350-314-20-1-1).
- 7 Install transmission hubs (TM 9-2350-314-20-1-2).
- 8 Install transmission and brake linkage (TM 9-2350-314-20-1-2).
- 9 Install speedometer and tachometer cables, adapters, and brackets (TM 9-2350-314-20-1-2).
- 10 Install sending units and protective covers (TM 9-2350-314-20-1-2).
- 11 Install VMS angle drive adapter (TM 9-2350-314-20-1-1).
- 12 Install VMS bracket, VMS assembly, and VMS shaft assembly (TM 9-2350-314-20-2-2).

Section I. POWERPACK - CONTINUED

4-1 REMOVAL AND INSTALLATION OF ENGINE AND TRANSMISSION-RELATED COMPONENTS - CONTINUED

c. Installation - Continued

NOTE

Aeration detector leads are connected when shroud is installed.

- 13 Install radiator shroud and cooling fan assemblies (TM 9-2350-314-20-1-1).
- 14 Install radiator and surge tank (TM 9-2350-314-20-1-1).
- 15 Fill engine and transmission oil and cooling system (TM 9-2350-314-10).

NOTE

FOLLOW-ON MAINTENANCE:
Install powerpack (TM 9-2350-314-20-1-1)

Section I. POWERPACK - CONTINUED

4-2 SEPARATION OF ENGINE FROM POWER TRAIN ASSEMBLY.

This task covers: a. Removal b. Installation

INITIAL SETUP

Tools

General mechanic's tool kit
(SC 5180-90-N26)
Engine lifting sling (item 39, Appx F)
Powerpack stand (item 35, Appx F) (fabricated)
Drain pan (item 14, Appx F)
Suitable lifting device
Torque wrench (item 59, Appx F)
Lifting sling (item 41, Appx F)

Materials/Parts

Gasket (item 9, Appx E)
Lockwashers (6) (item 80, Appx E)
Lockwashers (6) (item 81, Appx E)
Lockwashers (14) (item 79, Appx E)

Equipment Conditions

Engine and transmission
related components removed
(para 4-1)

Personnel Required

Two

References

TM 9-2350-314-20-1-1
TM 9-2350-314-24P-1
TM 9-247

a. Removal.

WARNING

Never crawl under equipment when performing maintenance unless equipment is securely blocked. Keep clear of equipment when it is being raised or lowered. Do not allow heavy components to swing while suspended by lifting device. Exercise extreme caution when working near a cable under tension. Failure to comply may result in equipment damage or injury to personnel.

CAUTION

Use care to avoid damage to powerpack components during disassembly, cleaning, inspection, repair, and reassembly. Nicks, scratches and dents, resulting from careless handling, may cause oil leakage or improper functioning. This could result in transmission failure. All defective parts must be replaced. Handling of heavy components with slings and hooks, and blocking the transmission for support in various positions, are important to prevent damage.

Section I. POWERPACK - CONTINUED

4-2 SEPARATION OF ENGINE FROM POWER TRAIN ASSEMBLY - CONTINUED

a. Removal - Continued

NOTE

- The engine assembly, transmission assembly, and transfer assembly will be shipped and stored in their respective containers. Refer to TM 9-247 for preservation, storage, and shipment of ordnance materials.
- Each assembly returned to an overhaul depot must include the component engine parts and accessories listed in para 4-5 prior to issuance of a serviceable replacement.

- 1 Attach sling to suitable lifting device. Attach sling to engine at four lifting eyes and take up slack in sling lines.
- 2 Check transmission support at transfer assembly. Make sure support will prevent transmission from rolling when engine is disconnected.
- 3 Remove vibration dampener (para 4-3).
- 4 Remove six screws (1), six flat washers (2), and six lockwashers (3) from tie bar (4) at transmission. Discard lockwashers.
- 5 Remove six screws (5), six flat washers (6), six lockwashers (7), and tie bar (4) from engine. Discard lockwashers.

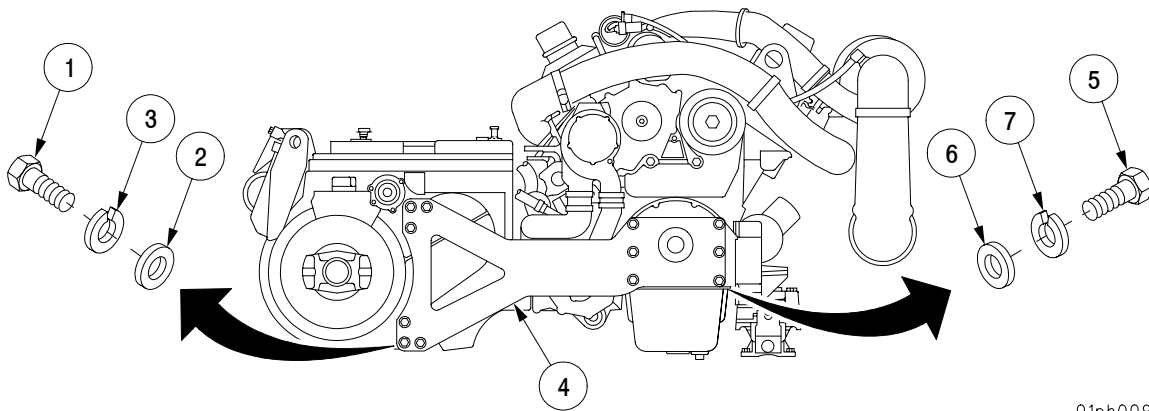

01ph009m

Section I. POWERPACK - CONTINUED

4-2 SEPARATION OF ENGINE FROM POWER TRAIN ASSEMBLY - CONTINUED

a. Removal - Continued**NOTE**

Length of screws will vary. Note length and location of screws to aid in installation. Two of the bolts are located between engine and transmission on front side of the flywheel housing.

- 6 Remove 14 screws (8), 14 flat washers (9), and 14 lockwashers (10). Discard lockwashers.
- 7 Remove engine supports and pull engine away from transfer assembly (11). Remove and discard gasket (12).
- 8 Remove oil tubes from engine (TM 9-2350-314-20-1-1).
- 9 Remove mass ring and flexible coupling, if required (para 4-4).
- 10 Remove generator cradle mounting bracket (TM 9-2350-314-20-1-2).
- 11 Remove engine mounts (TM 9-2350-314-20-1-1).

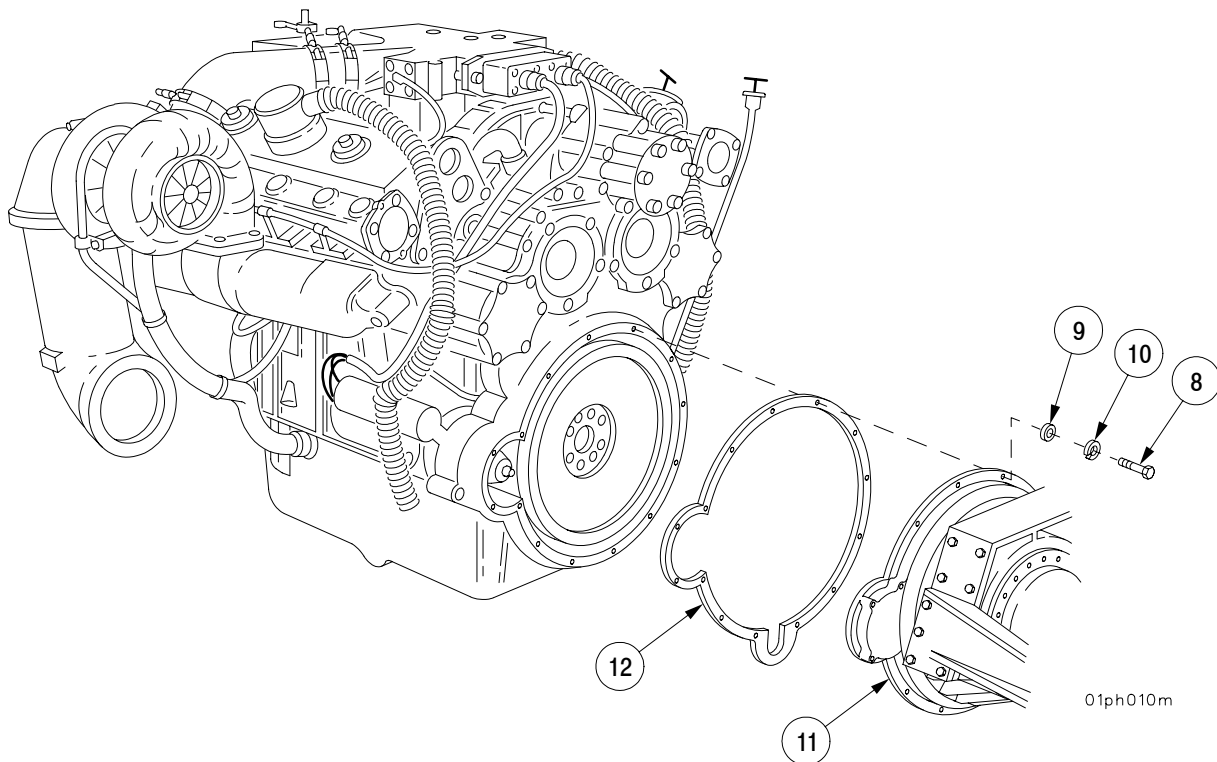

Section I. POWERPACK - CONTINUED

4-2 SEPARATION OF ENGINE FROM POWER TRAIN ASSEMBLY - CONTINUED

a. Removal - Continued

- 12 Remove exhaust blankets (TM 9-2350-314-20-1-1).
- 13 Remove air box pressure transducer and fittings (TM 9-2350-314-20-1-2).
- 14 Remove electric fuel pump and bracket (TM 9-2350-314-20-1-1).
- 15 Remove throttle linkage (TM 9-2350-314-20-1-1).
- 16 Remove fuel shut-off pulley and bracket (TM 9-2350-314-20-1-1).
- 17 Remove flywheel housing cover (TM 9-2350-314-20-1-1).

b. Installation.

- 1 Install flywheel housing cover (TM 9-2350-314-20-1-1).
- 2 Install fuel shut-off pulley and bracket (TM 9-2350-314-20-1-1).
- 3 Install throttle linkage (TM 9-2350-314-20-1-1).
- 4 Install electric fuel pump and bracket (TM 9-2350-314-20-1-1).
- 5 Install air box pressure transducer and fittings (TM 9-2350-314-20-1-2).
- 6 Install exhaust blankets (TM 9-2350-314-20-1-1).
- 7 Install engine mounts (TM 9-2350-314-20-1-1).
- 8 Install generator cradle mounting bracket (TM 9-2350-314-20-1-2).
- 9 Install mass ring and flexible coupling, if removed (para 4-4).
- 10 Install oil tubes on engine (TM 9-2350-314-20-1-1).
- 11 Install new gasket (12) and connect transfer assembly (11) to engine with 14 screws (8), 14 new lockwashers (10), and 14 flat washers (9).

Section I. POWERPACK - CONTINUED

4-2 SEPARATION OF ENGINE FROM POWER TRAIN ASSEMBLY - CONTINUED

b. Installation - Continued

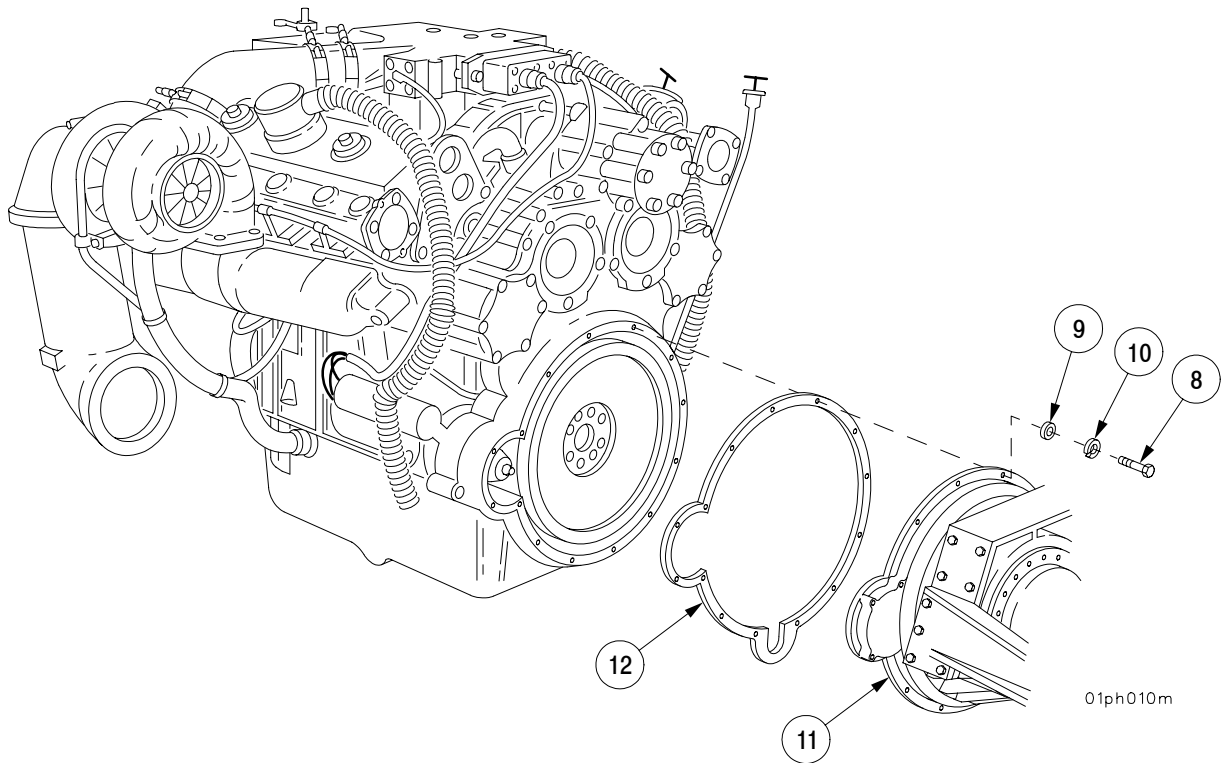

Section I. POWERPACK - CONTINUED

4-2 SEPARATION OF ENGINE FROM POWER TRAIN ASSEMBLY - CONTINUED

b. Installation - Continued

- 12 Install tie bar (4) on engine with six screws (5), six new lockwashers (7), and six flat washers (6).
- 13 Install tie bar (4) on transmission with six screws (1), six new lockwashers (3), and six flat washers (2). Torque six screws to 90-110 lb-ft (122-149 N·m).
- 14 Install vibration dampener (para 4-3).
- 15 Check transmission support at transfer assembly. Make sure support is stable and stationary at engine and transmission.
- 16 Remove sling from engine. Detach suitable lifting device from sling.

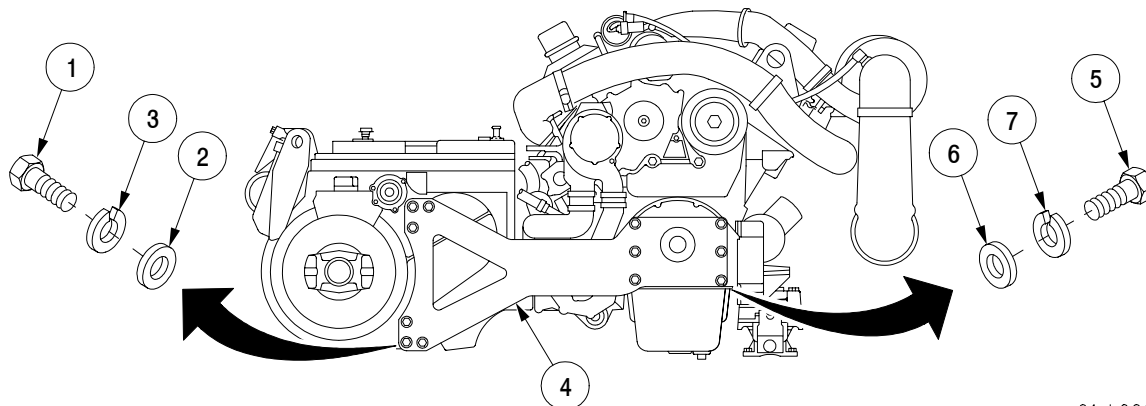

01ph009m

NOTE

FOLLOW-ON MAINTENANCE:
Install engine and transmission-related components (para 4-1)

Section II. ENGINE ASSEMBLY

4-3 VIBRATION DAMPENER AND ADAPTER.

This task covers: a. Removal

b. Installation

INITIAL SETUP

Tools

General mechanic's tool kit
(SC 5180-90-N26)
Torque wrench (item 59, Appx F)
Torque wrench (item 57, Appx F)
Socket wrench socket (item 47, Appx F)
Socket wrench hinged handle (item 23, Appx F)
Socket wrench adapter (item 2, Appx F)
Hammer (item 21, Appx F)

Equipment Conditions

Powerpack removed
(TM 9-2350-314-20-1-1)

Materials/Parts

Lockwashers (6) (item 75, Appx E)
Vibration dampener cone (item 22, Appx E)

a. Removal.

- 1 Remove six bolts (1), six lockwashers (2), and dampener (3) from adapter (4). Discard lockwashers.
- 2 Loosen bolt (5) approximately 1/8-in. (3 mm).
- 3 Strike bolt (5) to loosen vibration dampener cone (6) with soft-faced hammer.
- 4 Remove bolt (5), bushing (6), vibration dampener cone (7), and adapter (4) from engine crankshaft (8). Discard vibration dampener cone.

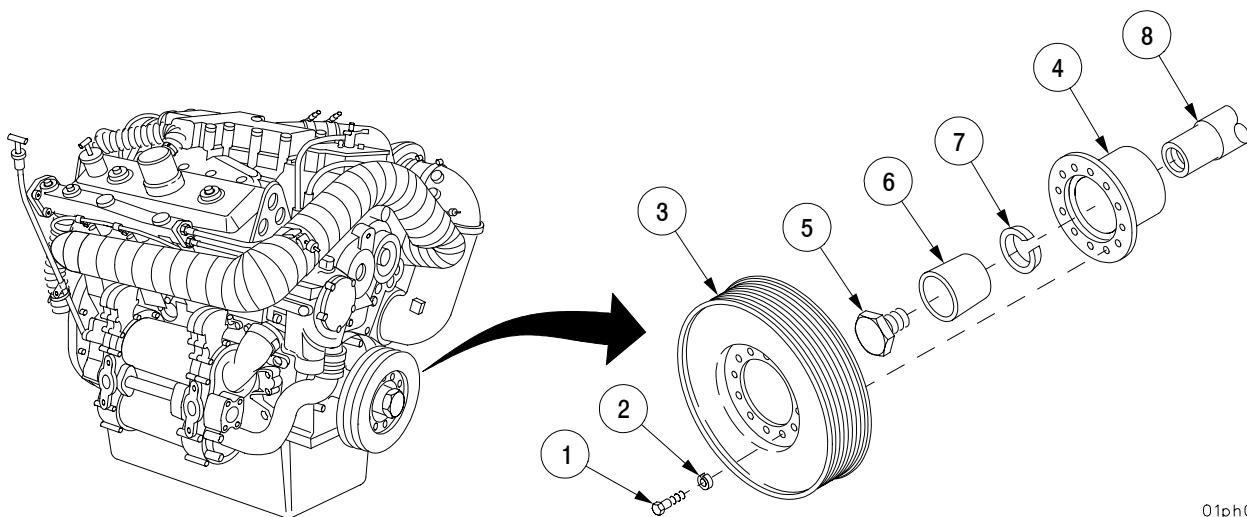

01ph011m

Section II. ENGINE ASSEMBLY - CONTINUED

4-3 VIBRATION DAMPENER AND ADAPTER - CONTINUED

b. Installation.

NOTE

Make sure vibration dampener cone is installed with tapered end toward adapter.

- 1 Install adapter (4) on engine crankshaft (8) with new vibration dampener cone (7), bushing (6), and bolt (5). Torque bolt to 180 lb-ft (244 N·m).
- 2 Strike end of bolt (5) with soft-faced hammer.
- 3 Torque bolt (5) to 290 lb-ft (393 N·m). Strike bolt (5) again.
- 4 Torque bolt (5) to 290-310 lb-ft (393-420 N·m).
- 5 Install dampener (3) on adapter (4) with six bolts (1) and six new lockwashers (2). Torque bolts to 57-63 lb-ft (77-85 N·m).

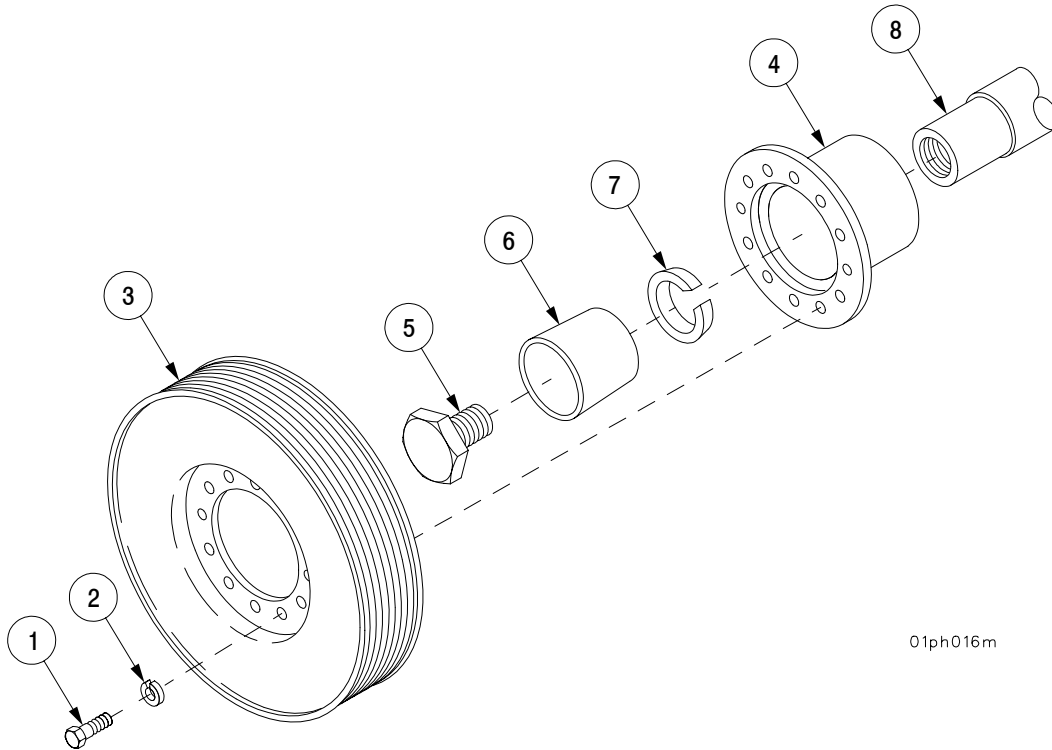

NOTE

FOLLOW-ON MAINTENANCE:
Install powerpack (TM 9-2350-314-20-1-1)

Section II. ENGINE ASSEMBLY - CONTINUED

4-4 MASS RING AND FLEXIBLE COUPLING.

This task covers: a. Removal b. Inspection c. Installation

INITIAL SETUP

Tools

General mechanic's tool kit
(SC 5180-90-N26)
Torque wrench (item 58, Appx F)

Equipment Conditions

Engine separated from power train assembly
(para 4-2)

Materials/Parts

Preformed packing (item 40, Appx E)
Adhesive (item 2, Appx B)
Self-locking bolts (12) (item 88, Appx E)

a. Removal.

Remove 12 self-locking bolts (1), mass ring (2), flexible coupling (3), and preformed packing (4) from flywheel (5). Discard preformed packing and self-locking bolts.

b. Inspection.

If rear surface of flexible coupling (3) is oil soaked, or springs or washers are broken, or flexible coupling (3) is distorted, replace flexible coupling (3).

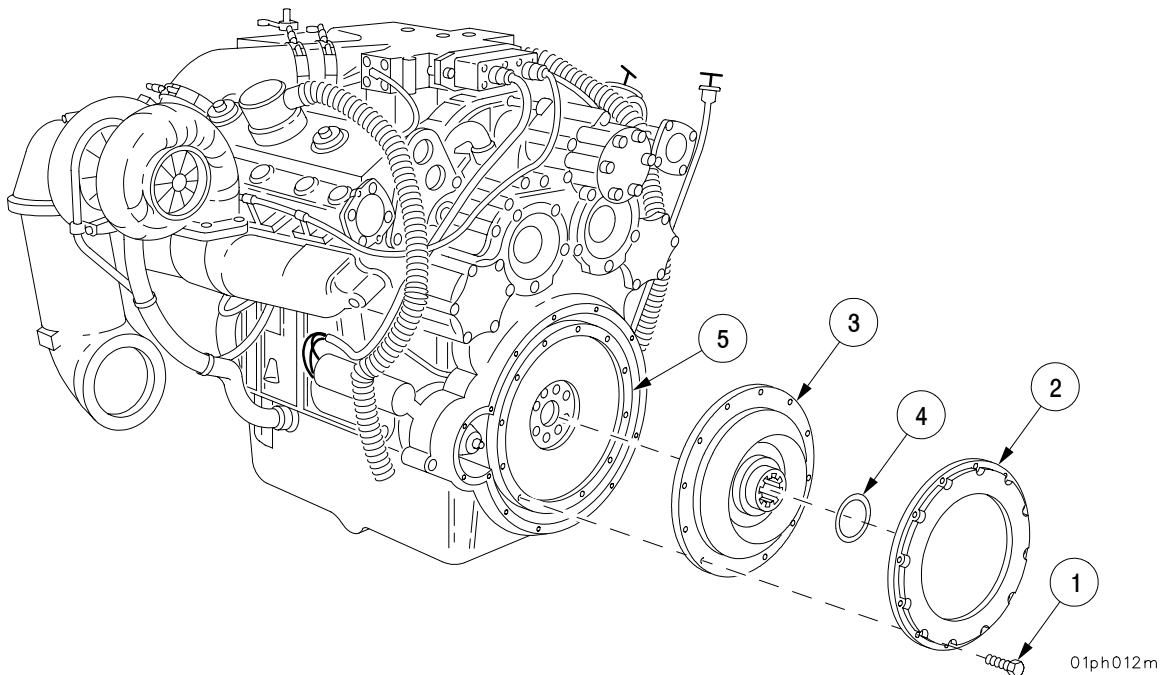

Section II. ENGINE ASSEMBLY - CONTINUED

4-4 MASS RING AND FLEXIBLE COUPLING - CONTINUED

c. Installation.

- 1 Apply adhesive to new preformed packing (4) and flexible coupling (3) groove.
- 2 Install new preformed packing (4) on flexible coupling (3).
- 3 Apply adhesive to flexible coupling (3) splines.
- 4 Install flexible coupling (3) and mass ring (2) on flywheel (5).
- 5 Secure mass ring (2) and flexible coupling (3) to flywheel (5) with 12 new self-locking bolts (1). Torque bolts to 40-50 lb-ft (54-67 N·m).

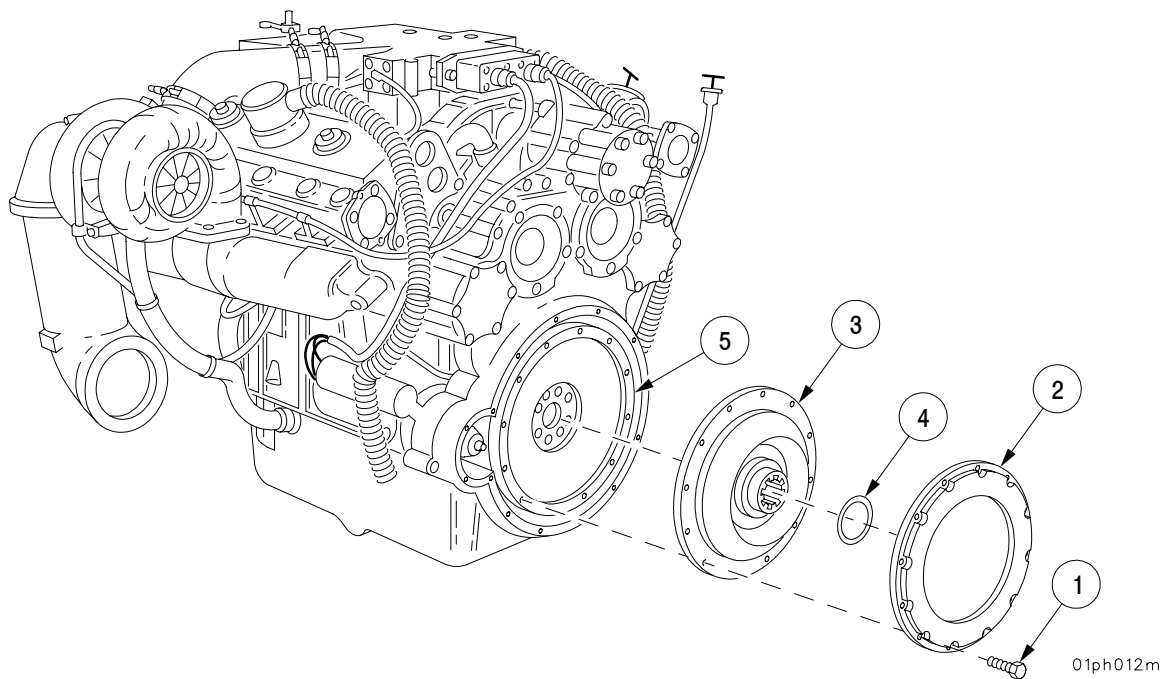

NOTE

FOLLOW-ON MAINTENANCE:
Mate engine with power train assembly (para 4-2)

Section III. PREPARATION FOR STORAGE OR SHIPMENT

4-5 SHIPPING AND STORAGE CONTAINERS, ENGINE PARTS, AND ACCESSORIES LIST.

NOTE

Refer to TM 9-2815-202-34 and TM 9-2520-234-35 for removal and installation of engine, transmission, and transfer assemblies to/from shipping and storage containers. Refer to TB 9-289 for repair of shipping and storage containers.

The following list of engine parts and accessories must accompany the engine assembly when returning an unserviceable engine assembly to an overhaul depot:

ENGINE PARTS AND ACCESSORIES

PART NO.	MFR CODE	DESCRIPTION
57K1003	19207	Engine w/Container (2815-01-335-4579) Engine Assembly Oil Pan, Engine Cover Assembly Cover Assembly Manifold, Water Manifold Exhaust R/B Manifold Exhaust L/B Fuel Pump Filter, Fuel/Secondary Filter, Fuel/Primary Starter, Engine Relay Solenoid Water Pump Filter Assembly Turbocharger Assembly Blower Assembly/Turbocharger Governor Pipe Exhaust, Crossover Hose Assembly, Crossover Hose Assembly, Crossover Oil Cooler Assembly Gage Rod Container, Top Container, Bottom Pipe Breather Housing Air Inlet Pipe Breather Pump, Fuel, Prime Glow Plug Controller

Section III. PREPARATION FOR STORAGE OR SHIPMENT - CONTINUED

4-5 SHIPPING AND STORAGE CONTAINERS, ENGINE PARTS, AND ACCESSORIES LIST - CONTINUED

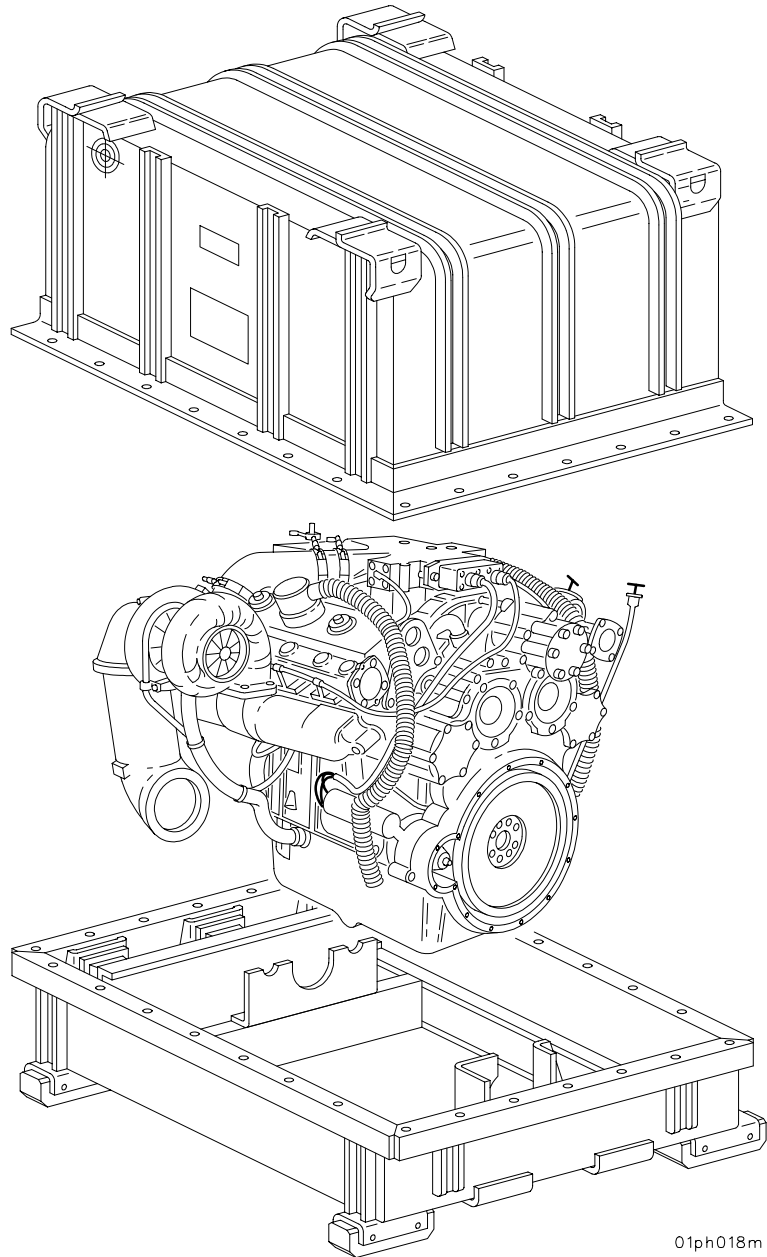

01ph018m

ENGINE ASSEMBLY WITH SHIPPING AND STORAGE CONTAINER

Section III. PREPARATION FOR STORAGE OR SHIPMENT - CONTINUED

**4-5 SHIPPING AND STORAGE CONTAINERS, ENGINE PARTS, AND ACCESSORIES
LIST - CONTINUED**

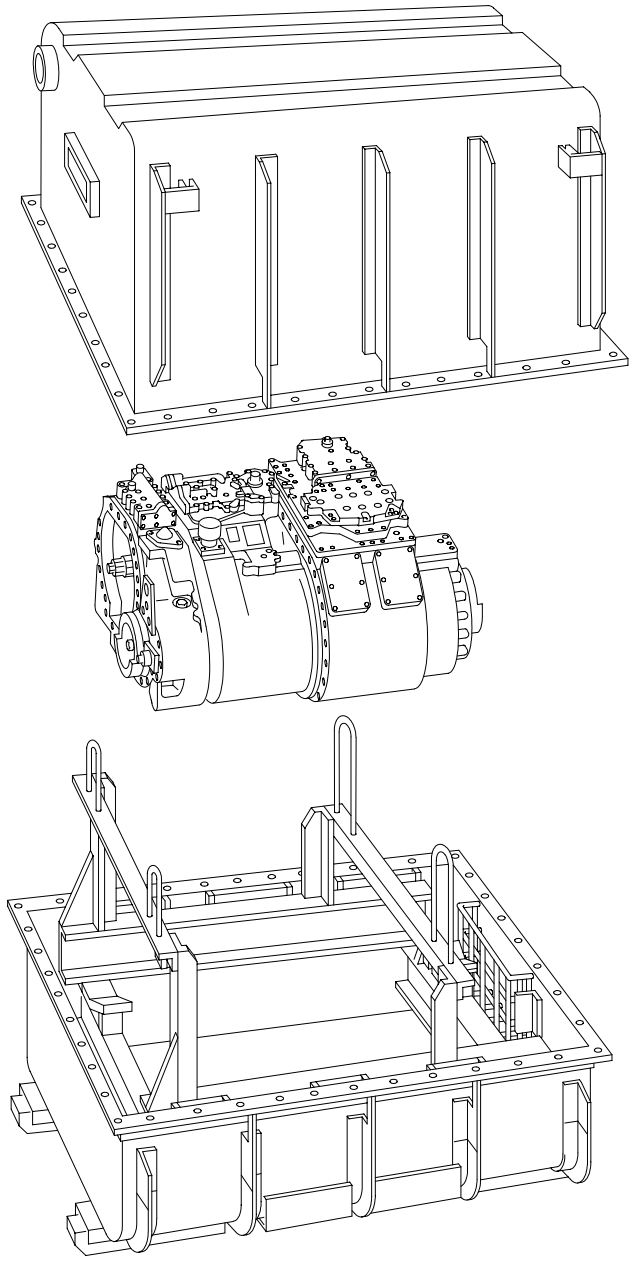

07ph012m

TRANSMISSION ASSEMBLY WITH SHIPPING AND STORAGE CONTAINER

Section III. PREPARATION FOR STORAGE OR SHIPMENT - CONTINUED

4-5 SHIPPING AND STORAGE CONTAINERS, ENGINE PARTS, AND ACCESSORIES
LIST - CONTINUED

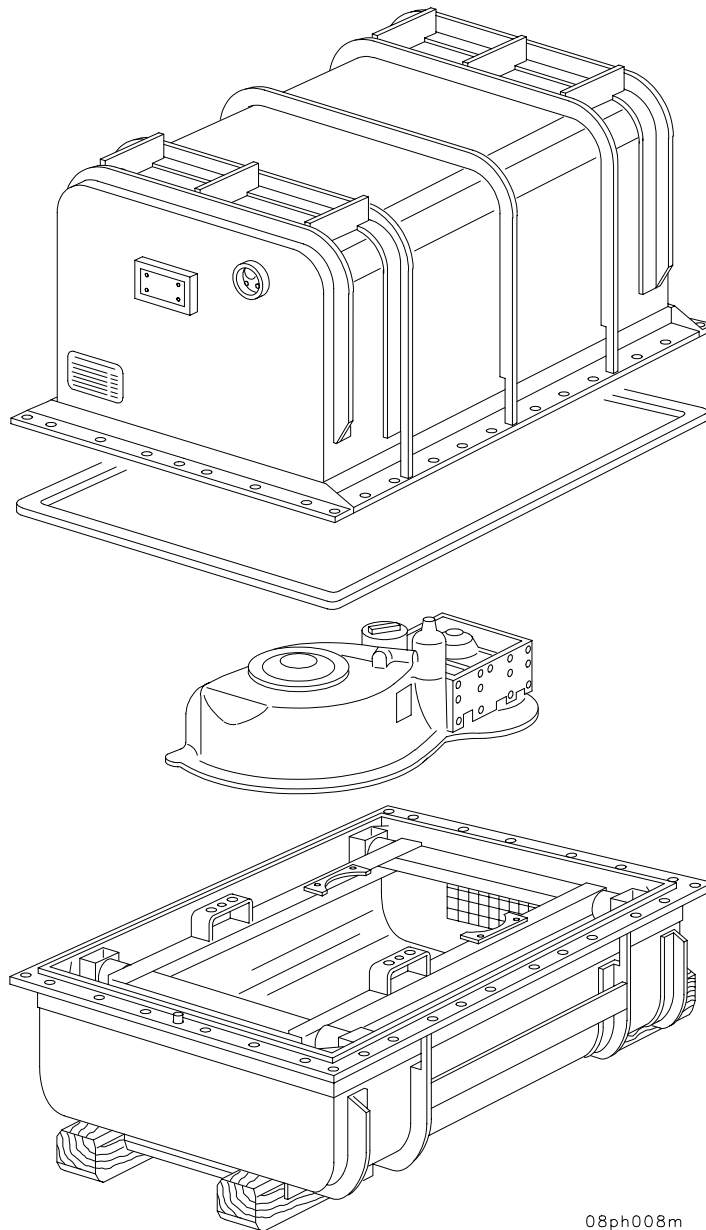

08ph008m

TRANSFER ASSEMBLY WITH SHIPPING AND STORAGE CONTAINER

Section IV. TRANSMISSION TRUNNION CAPS

4-6 TRANSMISSION TRUNNION REPLACEMENT CAPS.

- This task covers:
- a. Replacement Trunnion Cap Preparation
 - b. Replacement Trunnion Cap Installation
-

INITIAL SETUP

Tools

General mechanic's tool kit (SC 5180-90-N26)
Portable drill (item 16, Appx F)
Twist drill bit (item 15, Appx F)
Torque wrench (item 58, Appx F)

Equipment Conditions

Transmission trunnion cap removed
(TM 9-2350-314-20-1-1)

Materials/Parts

Marking dye - blue (item 20, Appx B)
Transmission trunnion cap replacement kit
(item 26, Appx E)

Section IV. TRANSMISSION TRUNNION CAPS - CONTINUED

4-6 TRANSMISSION TRUNNION REPLACEMENT CAPS - CONTINUED

a. Replacement Trunnion Cap Preparation.

- 1 Locate and mark centerline of two support bolt holes (1) on front and rear of support (2).
- 2 Locate and mark center of replacement trunnion cap (3) on front and rear vertical face of cap.
- 3 With powerpack installed and transmission positioned in supports, place replacement trunnion cap (3) with insert (4) over support (2). Align center mark on cap with hole center marks on support.
- 4 Measure pretorque clearance between cap (3) and support (2) at forward and rear edges. Clearance should be 0.005 to 0.007 in. (0.13 to 0.18 mm).
- 5 If clearance is less than 0.005 in. (0.13 mm), machine trunnion cap mating surfaces to obtain required clearance. If clearance is greater than 0.007 in. (0.18 mm), use shims (5) as required to reduce gap.
- 6 Remove replacement trunnion cap (3) with insert (4) and leave shims (5) (as required) in place on support (2).
- 7 Install two socket head setscrews (6) in two support bolt holes (1).

NOTE

Screw must protrude 0.005 to 0.010 in. (0.13 to 0.25 mm) above support face or shim surface, if shims are used.

- 8 Apply marking dye to mating surface of replacement trunnion cap (3).
- 9 Reposition replacement trunnion cap (3) and strike top of cap with hammer. Socket head setscrews (6) will mark hole location outlines in marking dye.
- 10 Remove replace trunnion cap (3) and socket head setscrews (6). Caps must be immediately marked "LF" or "RF" on forward surface to indicate if cap was removed from the left front or the right front (viewed from driver's compartment facing forward).
- 11 Drill two 0.531 to 0.541 in. (13.49 to 13.74 mm) holes from bottom of trunnion cap (3) using outline of setscrews as location points. Holes must be free of burrs.

Section IV. TRANSMISSION TRUNNION CAPS - CONTINUED

4-6 TRANSMISSION TRUNNION REPLACEMENT CAPS - CONTINUED

a. Replacement Trunnion Cap Preparation - Continued

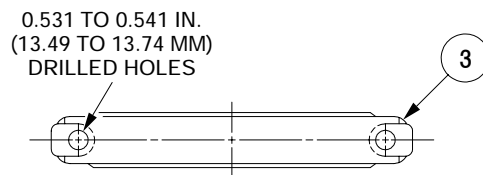
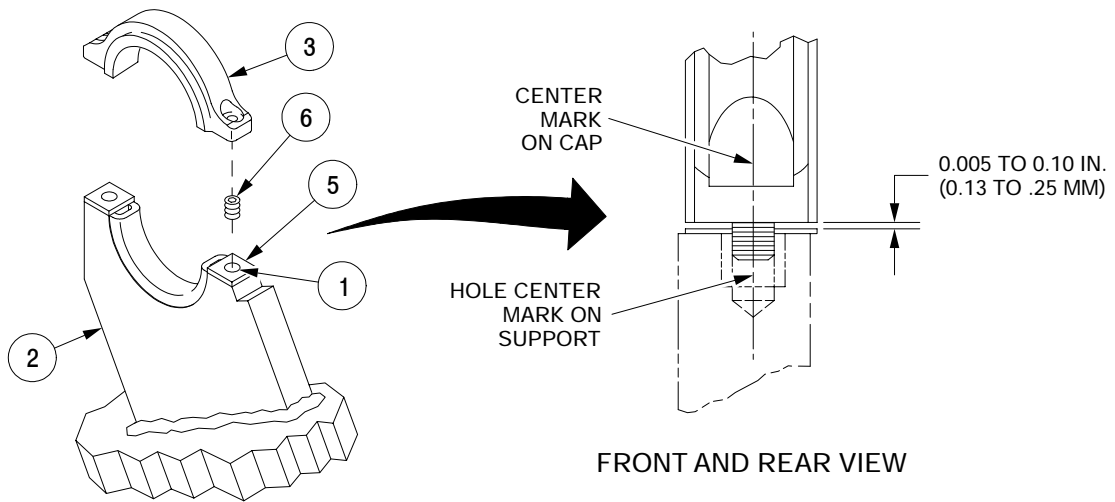
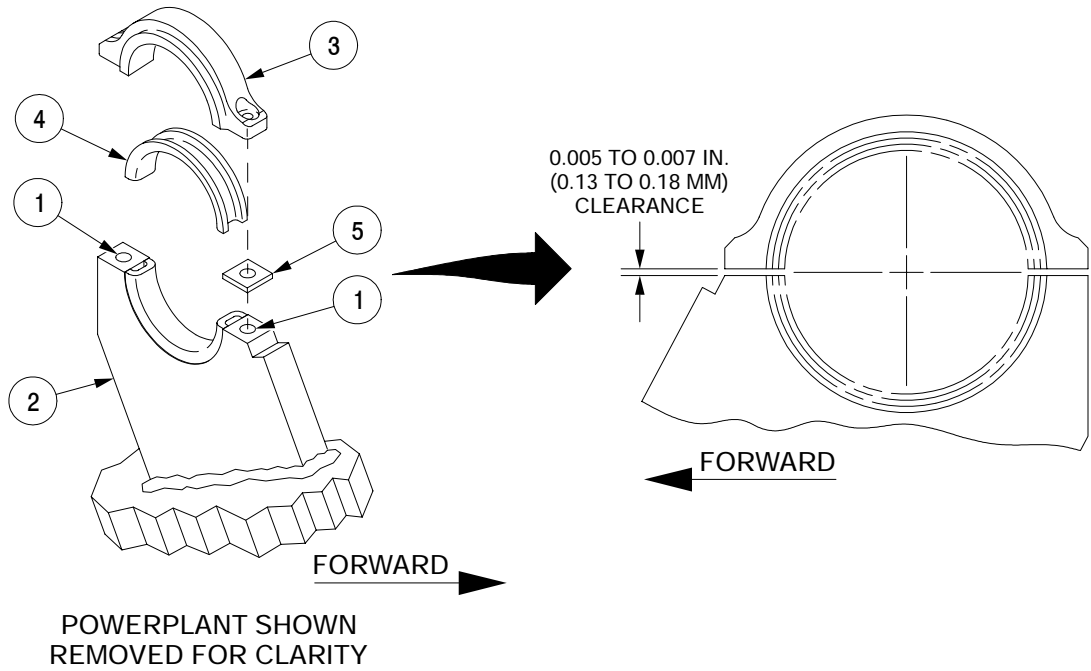

07ph008m

Section IV. TRANSMISSION TRUNNION CAPS - CONTINUED

4-6 TRANSMISSION TRUNNION REPLACEMENT CAPS - CONTINUED

b. Replacement Trunnion Cap Installation.

- 1 Align transmission insert (4) in support (2) and replacement trunnion cap (3).
- 2 Install shims (5) (as required), replacement trunnion cap (3), two flat washers (7), and two bolts (8 and 9). Do not tighten.
- 3 Torque rear bolt (8) to 85-90 lb-ft (115-122 N•m).
- 4 Torque forward bolt (9) to 85-90 lb-ft (115-122 N•m).

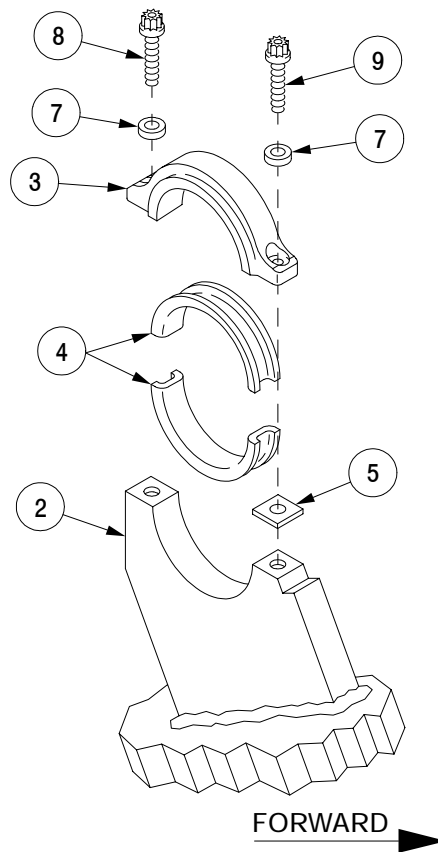

POWERPLANT SHOWN
REMOVED FOR CLARITY

07ph009m

NOTE

FOLLOW-ON MAINTENANCE:
Install transmission trunnion cap
(TM 9-2350-314-20-1-1)

Section V. FINAL DRIVE ASSEMBLY

4-7 FINAL DRIVE ASSEMBLY.

This task covers: a. Disassembly b. Inspection c. Assembly

INITIAL SETUP

Tools

General mechanic's tool kit
(SC 5180-90-N26)
Arbor press (item 5, Appx F)
Torque wrench (item 58, Appx F)
Torque wrench (item 59, Appx F)
Final drive stand (item 55, Appx F) (fabricated)
Socket wrench socket (item 46, Appx F)
Socket, crowfoot (item 43, Appx F)

Materials/Parts

Lockwashers (24) (item 78, Appx E)
Lockwashers (7) (item 80, Appx E)
Cotter pin (item 53, Appx E)
Seal (item 86, Appx E)
Seal (item 33, Appx E)
Gasket (item 3, Appx E)
Gasket (item 1, Appx E)
Gasket (item 2, Appx E)
Gasket (item 30, Appx E)
Sealing compound (item 27, Appx B)
Lubricating oil (item 15, Appx B)
Lubricating oil (item 16, Appx B)
Dry-cleaning solvent (item 29, Appx B)

Equipment Conditions

Final drive removed
(TM 9-2350-314-20-1-2)

Personnel Required

Two

References

TM 9-214
TM 9-2350-314-20-1-2

a. Disassembly.

- 1 Remove four screws (1), four lockwashers (2), cover (3), and gasket (4). Discard gasket and lockwashers.

NOTE

If optional seal arrangement was used, remove two seals; however, only one seal will be installed.

Section V. FINAL DRIVE ASSEMBLY - CONTINUED

4-7 FINAL DRIVE ASSEMBLY - CONTINUED

a. Disassembly - Continued

- 2 Remove seal (5). Discard seal.
- 3 Remove 12 screws (6), 12 lockwashers (7), cover (8), and gasket (9) from housing cover (10). Discard lockwashers and gasket.

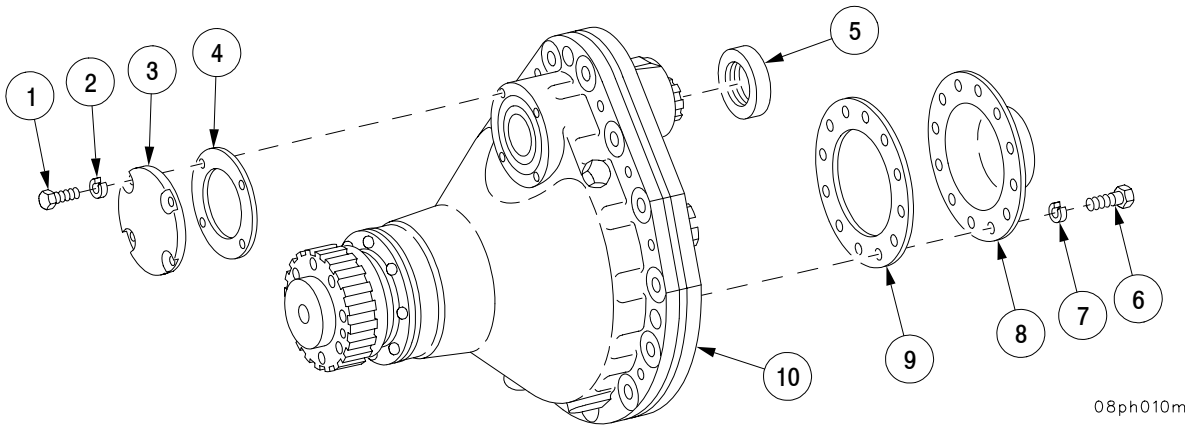

- 4 Remove seven screws (11), seven lockwashers (12), housing cover (10), and gasket (13) from final drive housing (14). Discard lockwashers and gasket.
- 5 Remove plug (15) from housing cover (10).
- 6 Remove input splined gearshaft (16) from final drive housing (14).
- 7 Remove two bearings (17) from splined gearshaft (16) using arbor press.

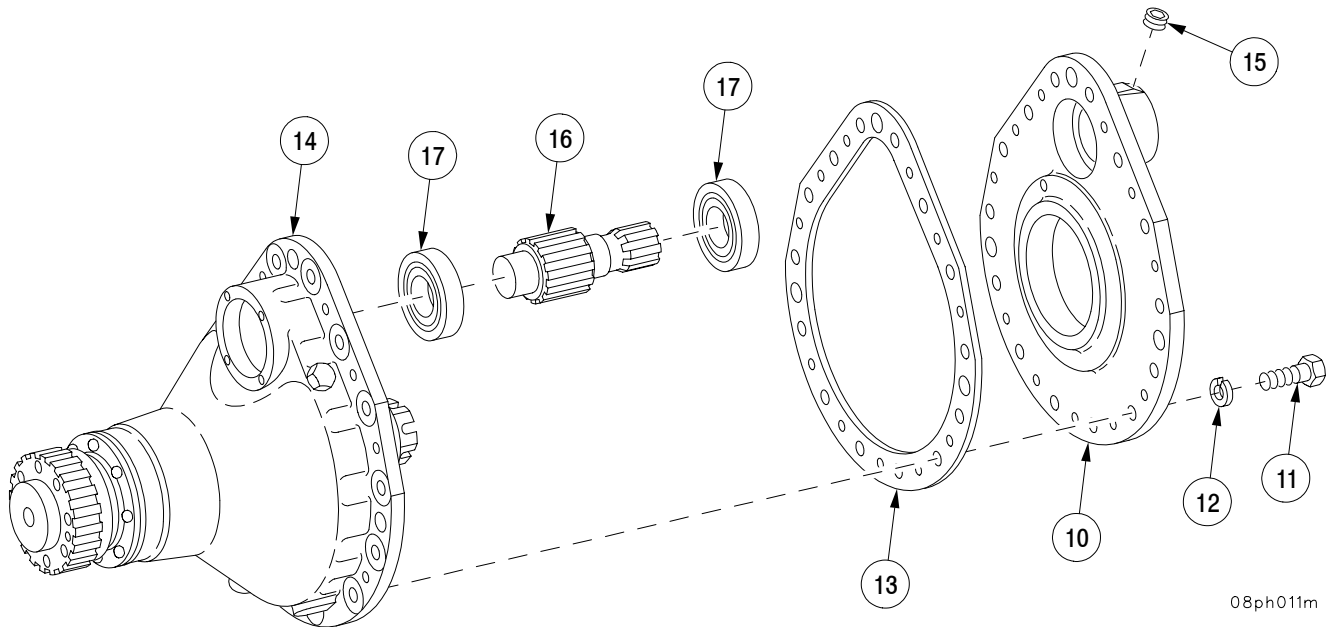

Section V. FINAL DRIVE ASSEMBLY - CONTINUED

4-7 FINAL DRIVE ASSEMBLY - CONTINUED

a. Disassembly - Continued

- 8 Remove cotter pin (18) and nut (19). Discard cotter pin.
- 9 Remove ring gear (20) and spacer (21) from output shaft (22).
- 10 Remove bearing (23) from ring gear (20).
- 11 Remove eight screws (24), eight lockwashers (25), output shaft (22), seal (26), cap (27), gasket (28) and bearing (29) from final drive housing (14). Discard lockwashers and gasket.
- 12 Remove bearing (29), cap (27), and seal (26) from output shaft (22). Discard seal.

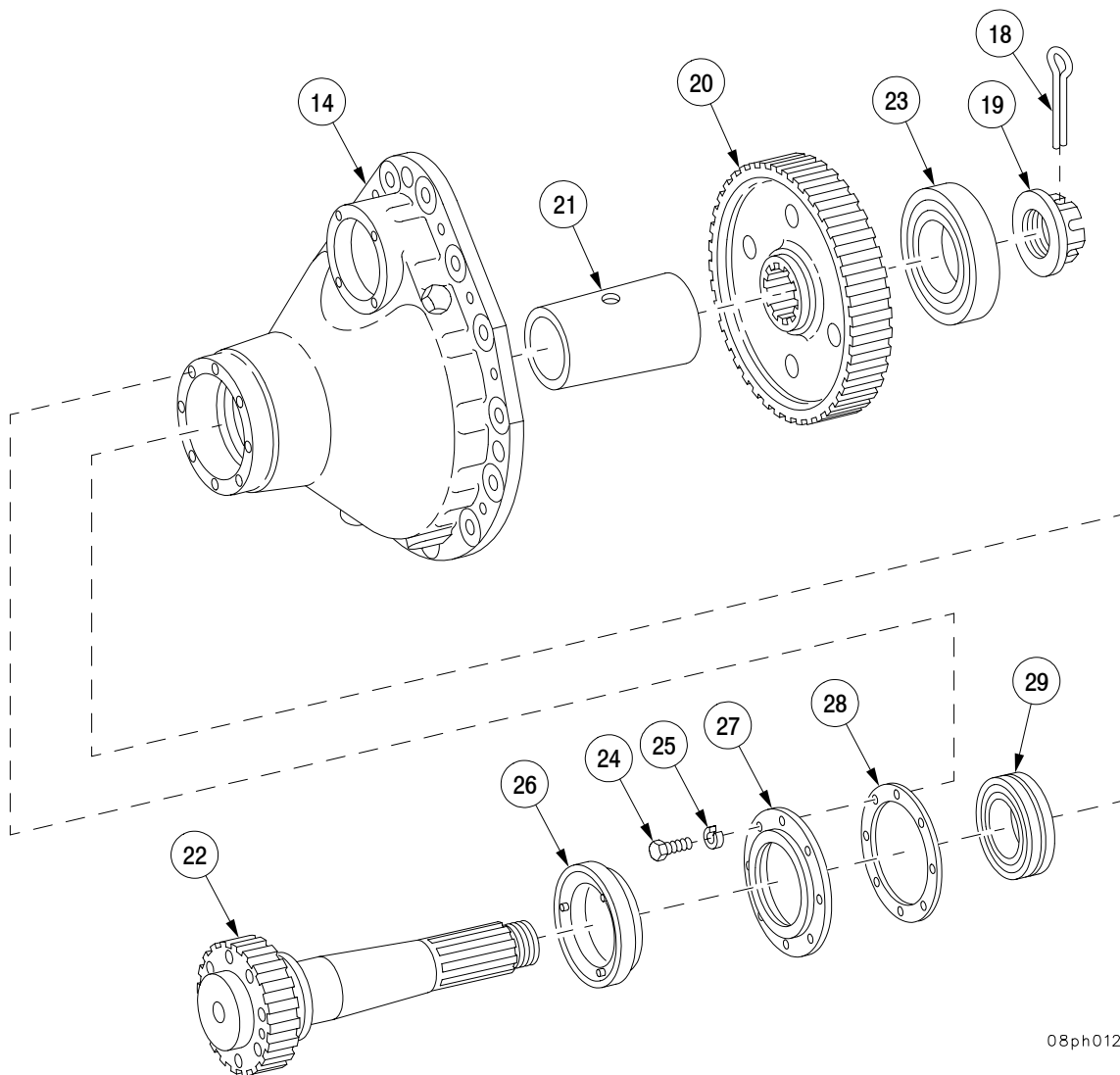

08ph012m

Section V. FINAL DRIVE ASSEMBLY - CONTINUED

4-7 FINAL DRIVE ASSEMBLY - CONTINUED

a. Disassembly - Continued

- 13 Remove two plugs (30) and two screws (31) from final drive housing (14).
- 14 Remove three pins (32) from final drive housing (14).
- 15 Remove pin (33) from output shaft (22).

WARNING

Dry-cleaning solvent (P-D-680), used to clean parts, is toxic and flammable. Wear protective goggles and gloves and use only in a well-ventilated area. Avoid contact with skin, eyes, and clothes. Do not breathe vapors. Do not use near open flame or excessive heat. Do not smoke when using solvent. Failure to do so could cause **SERIOUS INJURY**. If you become dizzy while using dry-cleaning solvent, get fresh air immediately, and if necessary, get medical attention. If contact with skin or clothes is made, flush thoroughly with water. If the solvent contacts your eyes, wash them with water immediately and obtain medical aid (ref. FM 21-11).

- 16 Clean all parts with dry-cleaning solvent.

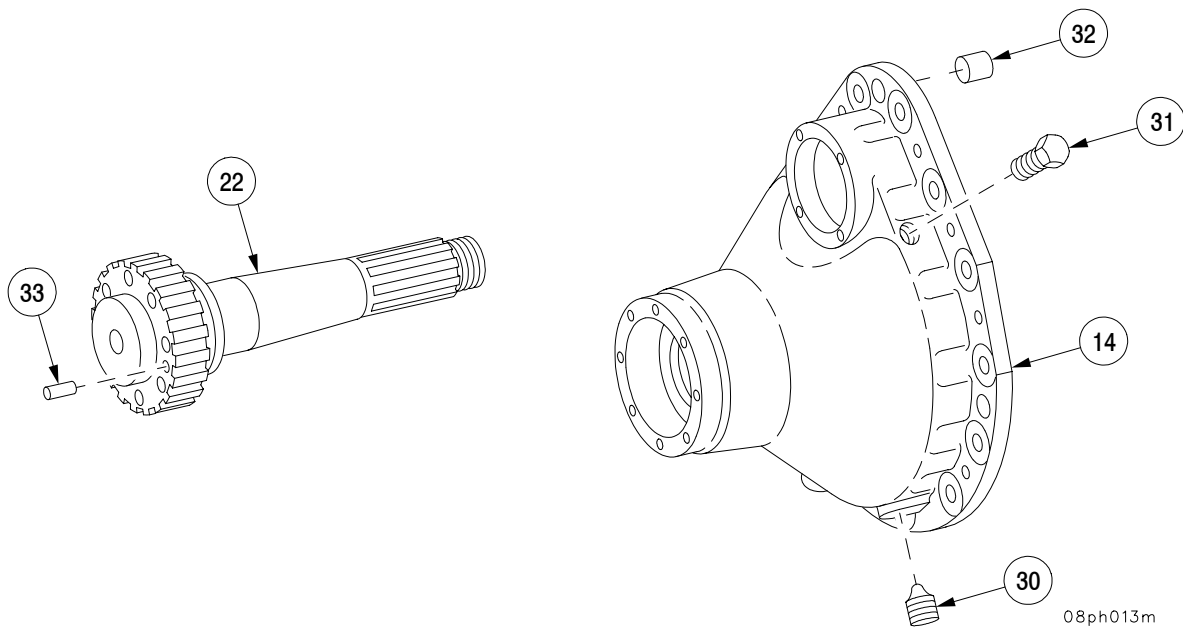

Section V. FINAL DRIVE ASSEMBLY - CONTINUED

4-7 FINAL DRIVE ASSEMBLY - CONTINUED

b. Inspection.

- 1 Inspect housing cover (10) for cracks or damage. Replace if defective.
- 2 Inspect housing cover (10) for stripped threads. Repair stripped threads (para 2-9).

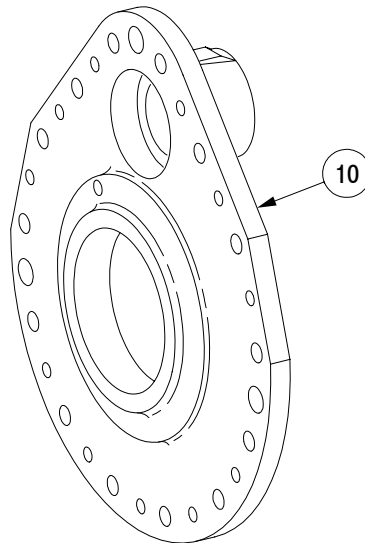

- 3 Inspect final drive housing (14) for cracks or damage. Replace if defective.
- 4 Inspect final drive housing (14) for stripped threads. Repair stripped threads (para 2-9).

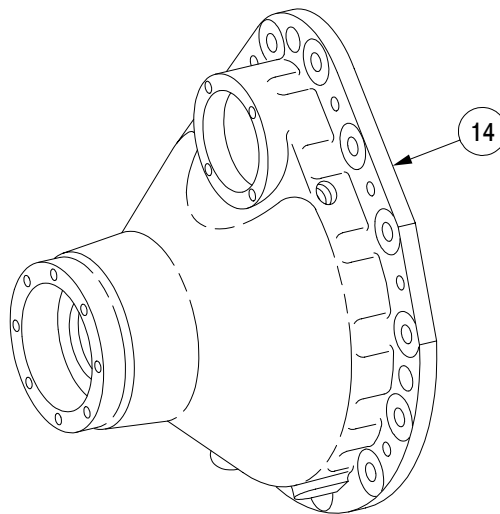

Section V. FINAL DRIVE ASSEMBLY - CONTINUED

4-7 FINAL DRIVE ASSEMBLY - CONTINUED

b. Inspection - Continued

- 5 Inspect input splined gearshaft (16) for damage or cracks, and for broken splines or gear teeth. Replace if damaged or defective.

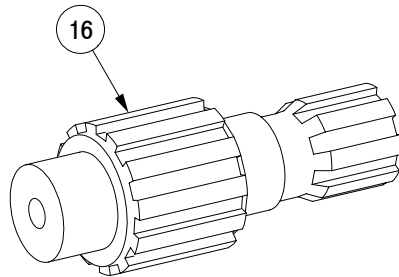

08ph016m

- 6 Inspect two bearings (17) for damage or defects (TM 9-214). Replace if defective.

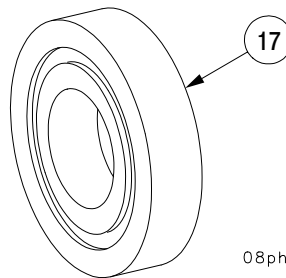

08ph017m

- 7 Inspect output shaft (22) for damage or defects, and for broken or missing splines on both ends of shaft. Replace if defective.

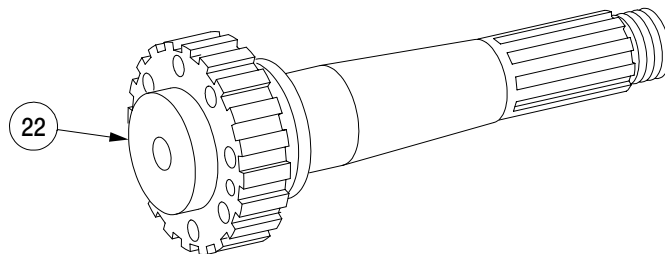

08ph018m

Section V. FINAL DRIVE ASSEMBLY - CONTINUED

4-7 FINAL DRIVE ASSEMBLY - CONTINUED

b. Inspection - Continued

- 8 Inspect ring gear (20) for broken or missing teeth. Replace if teeth are broken or missing.

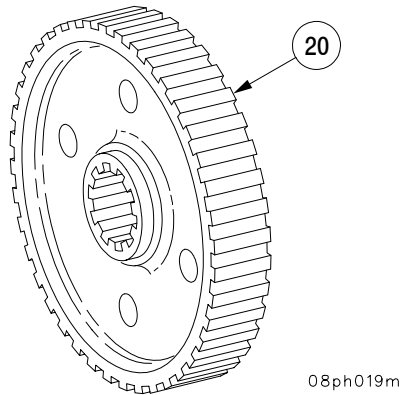

- 9 Inspect bearing (23) and bearing (29) for damage or defects (TM 9-214). Replace if defective.

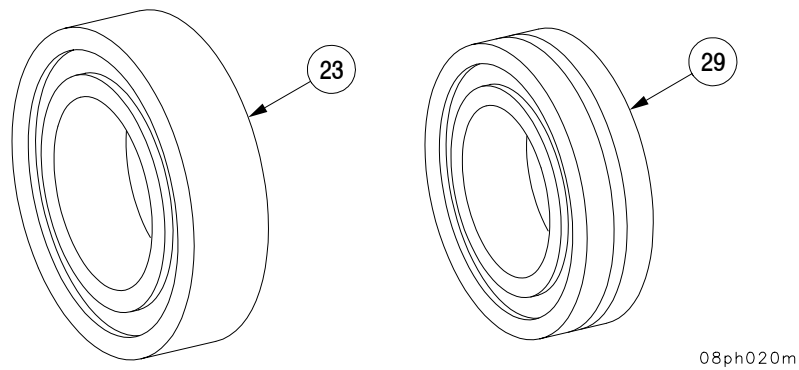

- 10 Inspect spacer (21) for cracks or distortion. Replace if spacer is cracked or ends are not smooth.

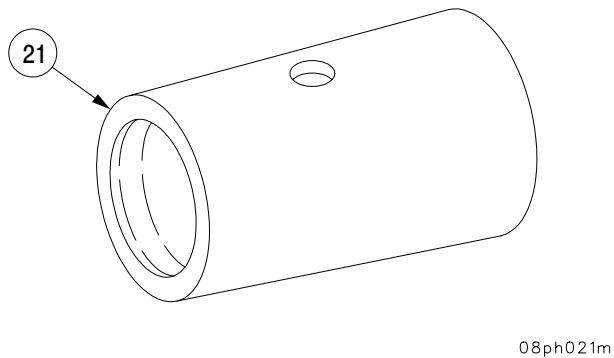

Section V. FINAL DRIVE ASSEMBLY - CONTINUED

4-7 FINAL DRIVE ASSEMBLY - CONTINUED

c. Assembly.

- 1 Apply lubricating oil (item 15, Appx B) to all threads prior to assembling.
- 2 Install two plugs (30) and two screws (31) in final drive housing (14).



Make sure all bearings are free from dirt and foreign material. Failure to comply may cause damage to equipment.

- 3 Apply lubricating oil (item 15, Appx B) to all bearings.
- 4 Apply sealing compound to outside diameter of new oil seal (26).
- 5 Install bearing (29), new seal (26), cap (27) and new gasket (28) on output shaft (22).
- 6 Install output shaft (22) in final drive housing (14).
- 7 Install eight new lockwashers (25) and eight screws (24) securing cap (27). Torque screws to 35-40 lb-ft (47-54 N·m).

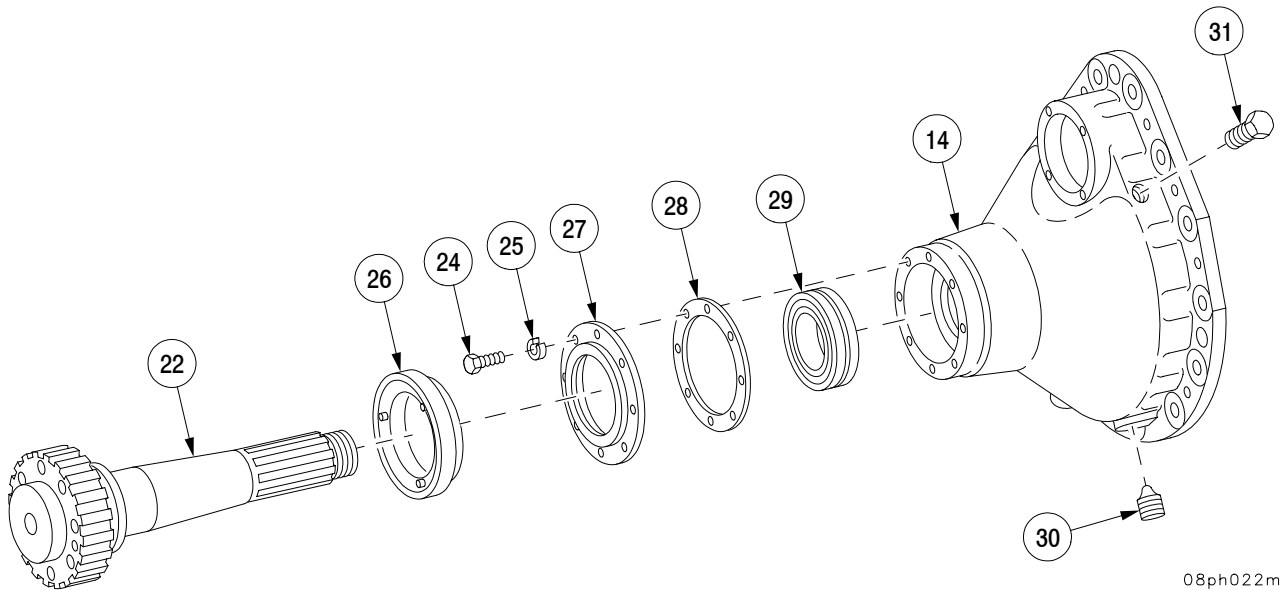

Section V. FINAL DRIVE ASSEMBLY - CONTINUED

4-7 FINAL DRIVE ASSEMBLY - CONTINUED

c. Assembly - Continued

- 8 Install bearing (23) on ring gear (20).
- 9 Place final drive housing (14) in final drive stand.
- 10 Install spacer (21) and ring gear (20) on output shaft (22).
- 11 Install nut (19) on output shaft (22).
- 12 Torque nut (19) as follows:
 - (a) Torque nut (19) to 450 ± 25 lb-ft (610 ± 34 N·m).
 - (b) If slot in nut (19) is aligned with shaft cotter pin hole, install new cotter pin (18).
 - (c) If slot in nut (19) is not aligned with shaft cotter pin hole, do not back-off nut (19).
 - (d) Continue to tighten (30° max) until a slot in nut (19) aligns with the shaft cotter pin hole. Install new cotter pin (18).

NOTE

When installing cotter pin, hold head tightly in place with pry bar and bend long leg of cotter pin onto flat of nut. Bend short leg as far as, but not beyond, end of output shaft.

- 13 Install new cotter pin (18) in nut (19).

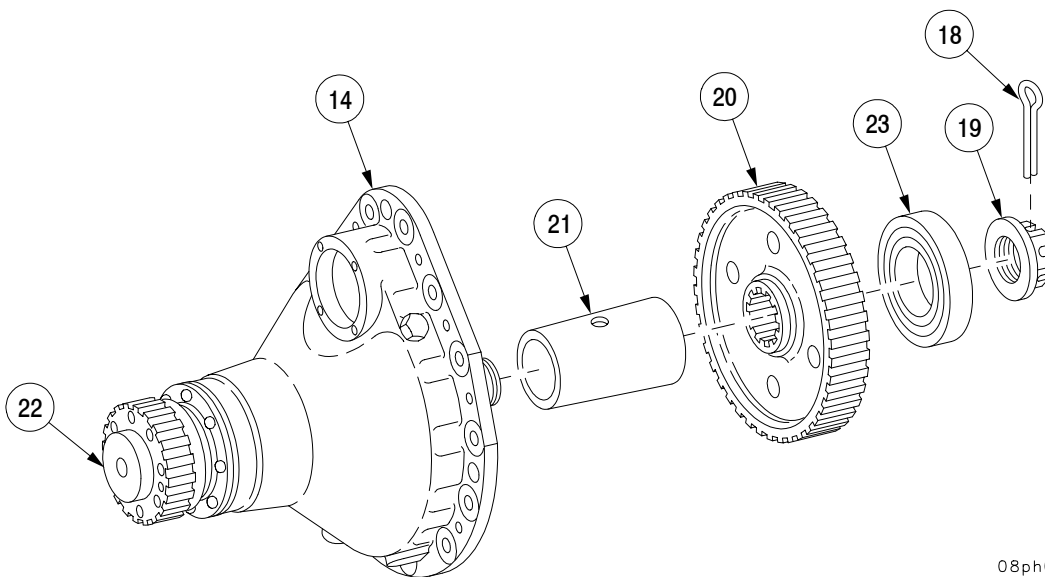

08ph023m

Section V. FINAL DRIVE ASSEMBLY - CONTINUED

4-7 FINAL DRIVE ASSEMBLY - CONTINUED

c. Assembly - Continued

- 14 Install two bearings (17) on splined gearshaft (16).
- 15 Install splined gearshaft (16) in final drive housing (14).
- 16 Install three pins (32) in final drive housing (14).

CAUTION

Ensure splined gearshaft and bearings are centered when installing cover.

- 17 Install new gasket (13) and housing cover (10) on final drive housing (14) with seven screws (11) and seven new lockwashers (12). Torque screws to 75-80 lb-ft (101-108 N·m).
- 18 Install plug (15) in housing cover (10).

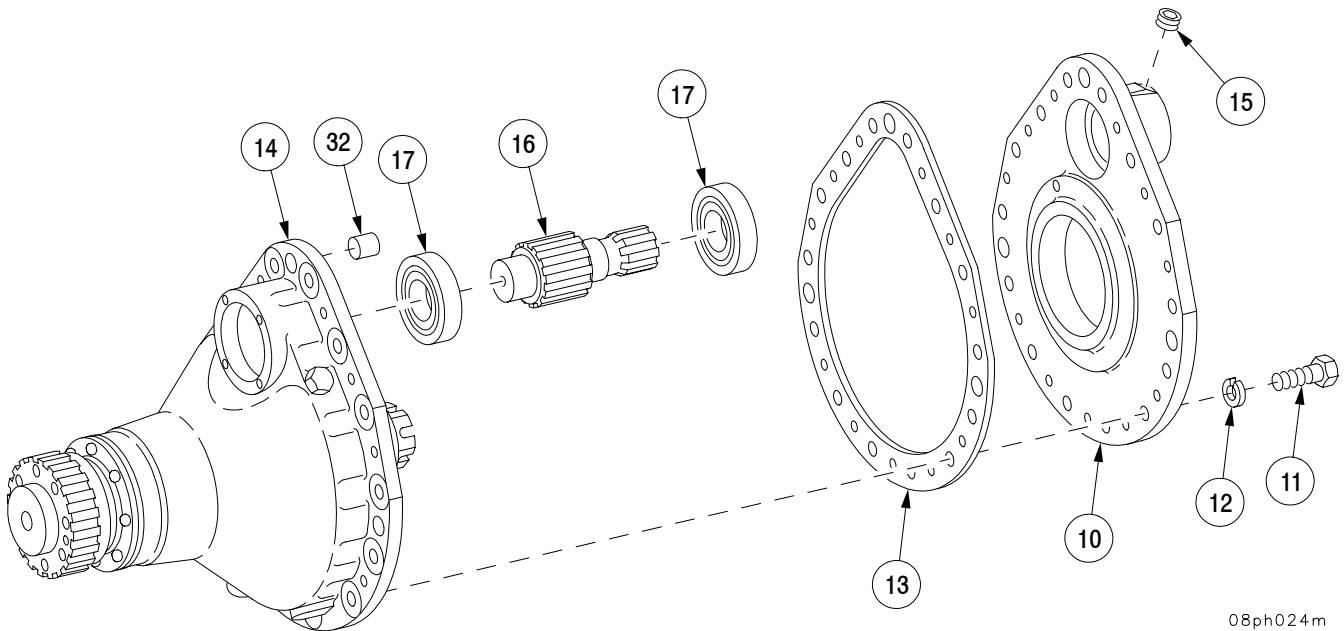

08ph024m

Section V. FINAL DRIVE ASSEMBLY - CONTINUED

4-7 FINAL DRIVE ASSEMBLY - CONTINUED

c. Assembly - Continued

- 19 Install new gasket (9) and cover (8) on housing cover (10) with 12 screws (6) and 12 new lockwashers (7). Torque screws to 35-40 lb-ft (47-54 N·m).
- 20 Soak new seal (5) in lubricating oil (item 15, Appx B) for one hour minimum, at 250°F (121°C).
- 21 Install new seal (5) in housing cover (10).
- 22 Remove final drive assembly from final drive stand.
- 23 Install new gasket (4) and cover (3) on final drive housing (14) with four screws (1) and four new lockwashers (2). Torque screws to 35-40 lb-ft (47-54 N·m).
- 24 Install pin (33) in output shaft (22).

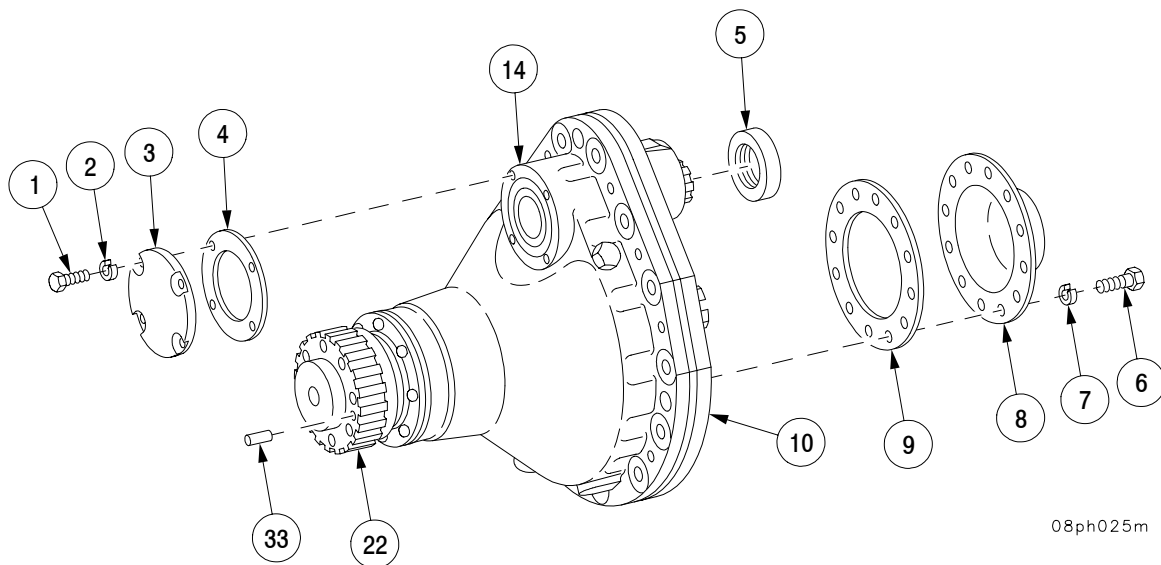
NOTE

FOLLOW-ON MAINTENANCE:
 Install final drive (TM 9-2350-314-20-1-2)

CHAPTER 5 FUEL SYSTEM

GENERAL

This chapter illustrates and defines direct support procedures for removal, disassembly, assembly, and installation of the fuel pumps, air cleaner blower assembly, and related components. This chapter also contains procedures for fuel tank repair, and inspection of the fuel pumps and air cleaner blower assembly.

<u>CONTENTS</u>	<u>Page</u>
Section I. AIR CLEANER	
5-1 AIR CLEANER BLOWER ASSEMBLY	5-2
Section II. TANKS, LINES, FITTINGS, AND HEADERS	
5-2 FUEL TANKS	5-9
5-3 FUEL TANK PADS AND HULL-MOUNTED PADS	5-24
5-4 FUEL TANK MOUNTING PLATE AND RETAINING BAND	5-26

Section I. AIR CLEANER

5-1 AIR CLEANER BLOWER ASSEMBLY.

This task covers: a. Disassembly b. Inspection c. Assembly

INITIAL SETUP

Tools

Fuel & electrical tool kit
(SC 5180-95-B08)
Multimeter (item 31, Appx F)
Growler (item 20, Appx F)
Snapping pliers (item 33, Appx F)
Puller, common mechanical
(item 36, Appx F)

Materials/Parts

Preformed packing (item 5, Appx E)
Lockwashers (11) (item 61, Appx E)
Lockwasher (item 70, Appx E)
Lockwashers (5) (item 60, Appx E)
Lockwashers (2) (item 72, Appx E)
Self-locking nut (item 50, Appx E)
Preformed packing (item 55, Appx E)

Materials/Parts - Continued

Spring pin (item 42, Appx E)
Spring washer (item 32, Appx E)
Spacer (item 10, Appx E)
Self-tapping screws (2) (item 51, Appx E)

Equipment Conditions

Air cleaner bracket and blower assembly
removed (TM 9-2350-314-20-1-1)

References

TM 9-2350-314-20-1-1

a. Disassembly.

- 1 Remove 10 screws (1), 10 lockwashers (2), and motor cover (3). Discard lockwashers.
- 2 Remove screw (4), lockwasher (5), and clip (6) from end bell (7). Discard lockwasher.
- 3 Slide insulation sleeve (8) from connection of capacitor electrical lead (9) and motor lead connector (10).
- 4 Disconnect capacitor electrical lead (9) from motor lead connector (10) and remove insulation sleeve (8).
- 5 Remove screw (11), lockwasher (12), capacitor ground lead (13), and motor ground (14) from end bell (7). Reinstall screw (11) into end bell (7) with motor ground lead (14). Discard lockwasher.

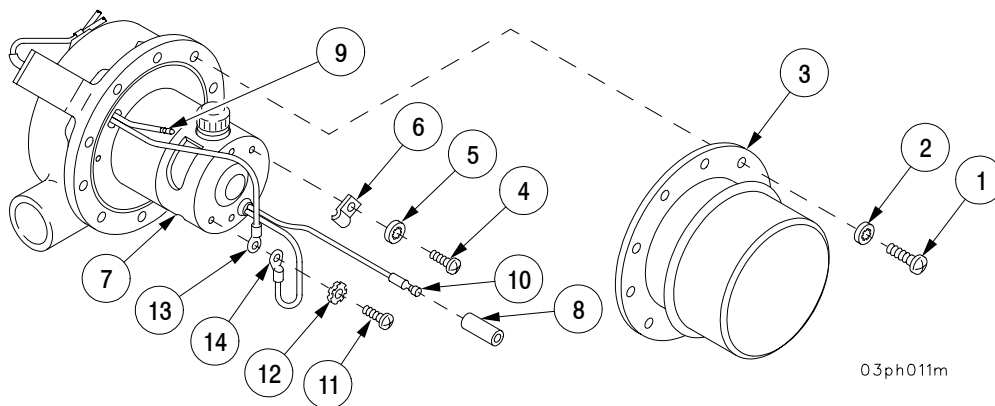

03ph011m

Section I. AIR CLEANER - CONTINUED

5-1 AIR CLEANER BLOWER ASSEMBLY - CONTINUED

a. Disassembly - Continued

- 6 Remove motor assembly (15) and two preformed packings (16) and (17) from impeller housing (18). Discard preformed packings.
- 7 Remove screw (19), lockwasher (20), ground lead (21), and clip (22) from impeller housing (18). Discard lockwasher. Reinstall screw (19) and clip (22).
- 8 Remove four screws (23), four lockwashers (24), and lead assembly with capacitor (25), from impeller housing (18). Discard lockwashers.
- 9 Remove spring pin (26) from impeller housing (18). Discard spring pin.

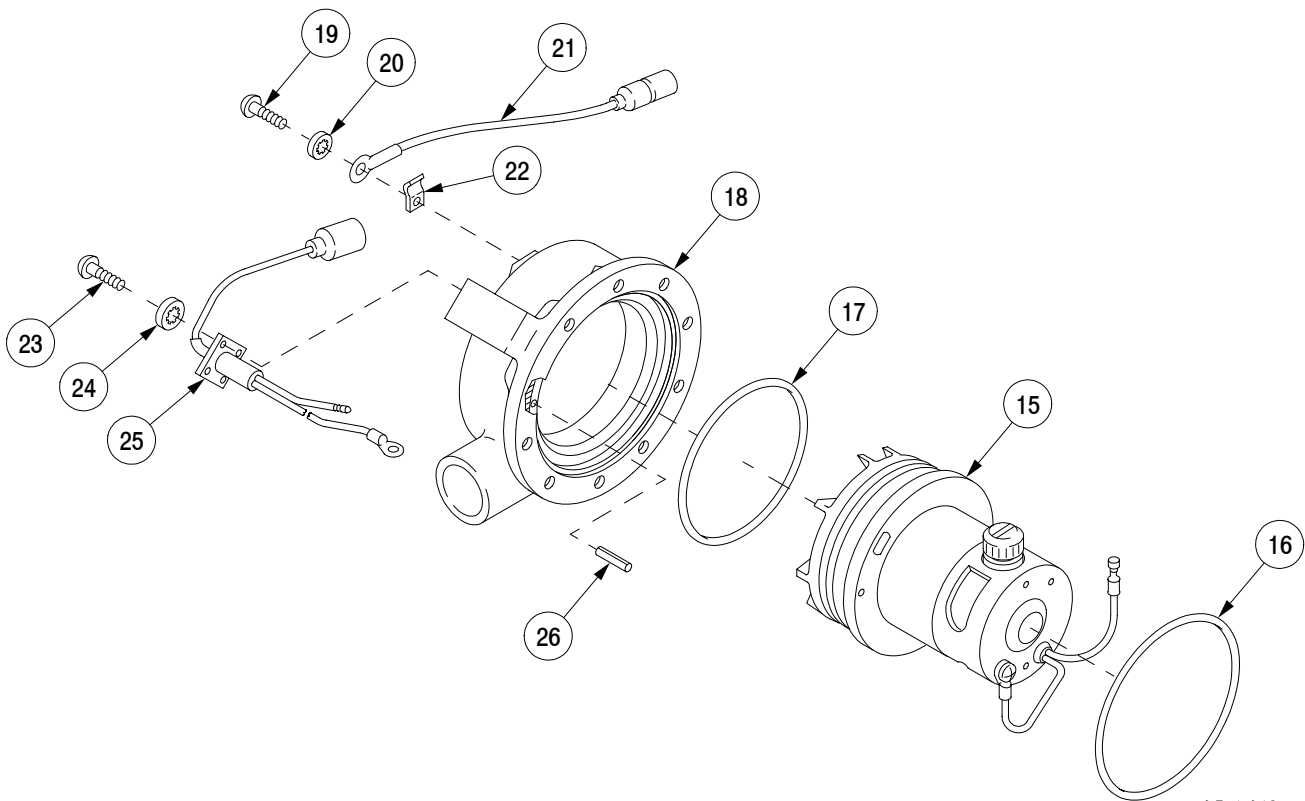

03ph012m

Section I. AIR CLEANER - CONTINUED

5-1 AIR CLEANER BLOWER ASSEMBLY - CONTINUED

a. Disassembly - Continued

- 10 Remove self-locking nut (27), unscrew and remove impeller (28), two flat washers (29), and flat washer (30). Discard self-locking nut.
- 11 Remove two brush caps (31) and two brushes (32) from stator assembly (33).
- 12 Remove two screws (34) and two lockwashers (35). Discard lockwashers.
- 13 Separate end cap (36) from stator assembly (33). Remove and discard spring washer (37).
- 14 Remove two self-tapping screws (38) with captive lockwashers and armature (39) from end cap (36). Discard self-tapping screws.
- 15 Remove two bearings (40) and retainer (41) from armature (39). Discard snaprings.
- 16 Remove spacer (42) from end cap (36). Discard spacer.

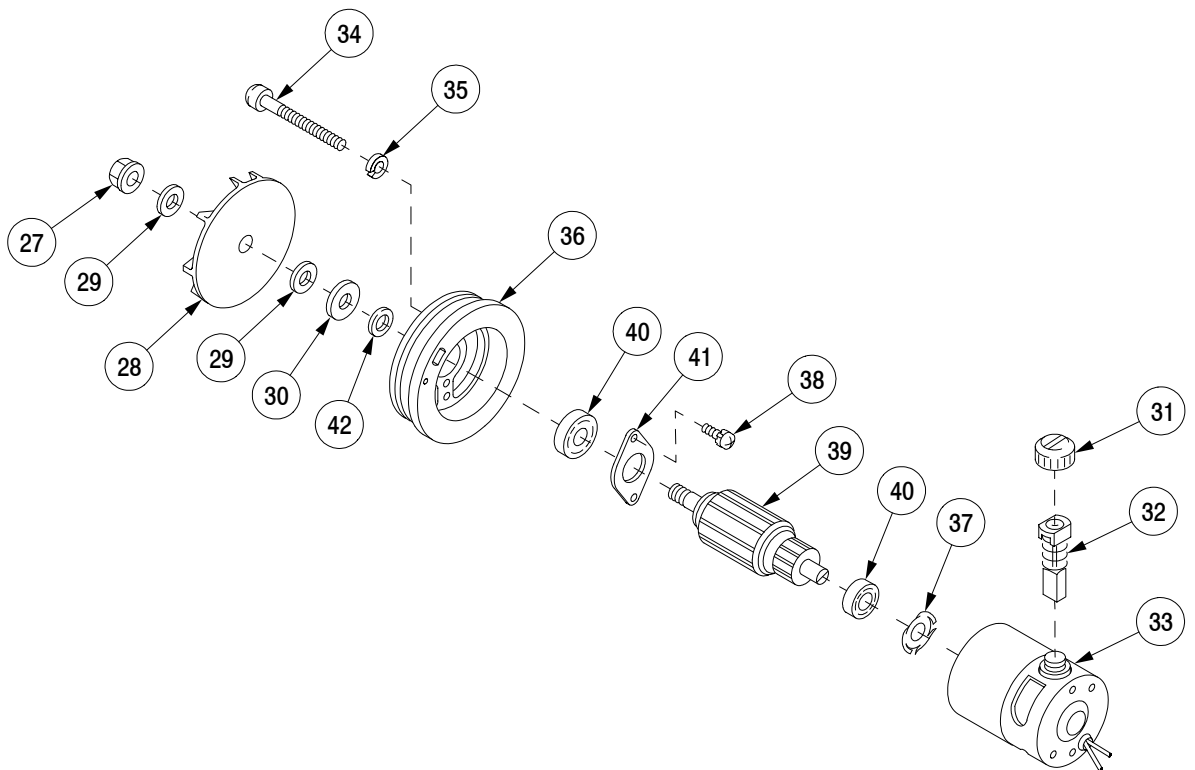

03ph013m

Section I. AIR CLEANER - CONTINUED

5-1 AIR CLEANER BLOWER ASSEMBLY - CONTINUED

b. Inspection.

- 1 Test armature (39) on growler. Use lathe to turn down armature. Undercut mica 1/32 in., if required.
- 2 Test stator assembly (33) for continuity, using multimeter. Replace if stator has open or shorted field winding.
- 3 Inspect end cap (36). Replace if damaged.
- 4 Inspect impeller (28). Replace if damaged.
- 5 Perform static balance test on impeller (28). If impeller (28) is out of balance, replace.
- 6 Test capacitor (25) for continuity using multimeter. If resistance value is shown on multimeter, replace capacitor (25).
- 7 Inspect impeller housing (18). Replace if damaged.
- 8 Inspect end bell of stator assembly (33). Replace if damaged.
- 9 Inspect motor cover (3). Replace if damaged.

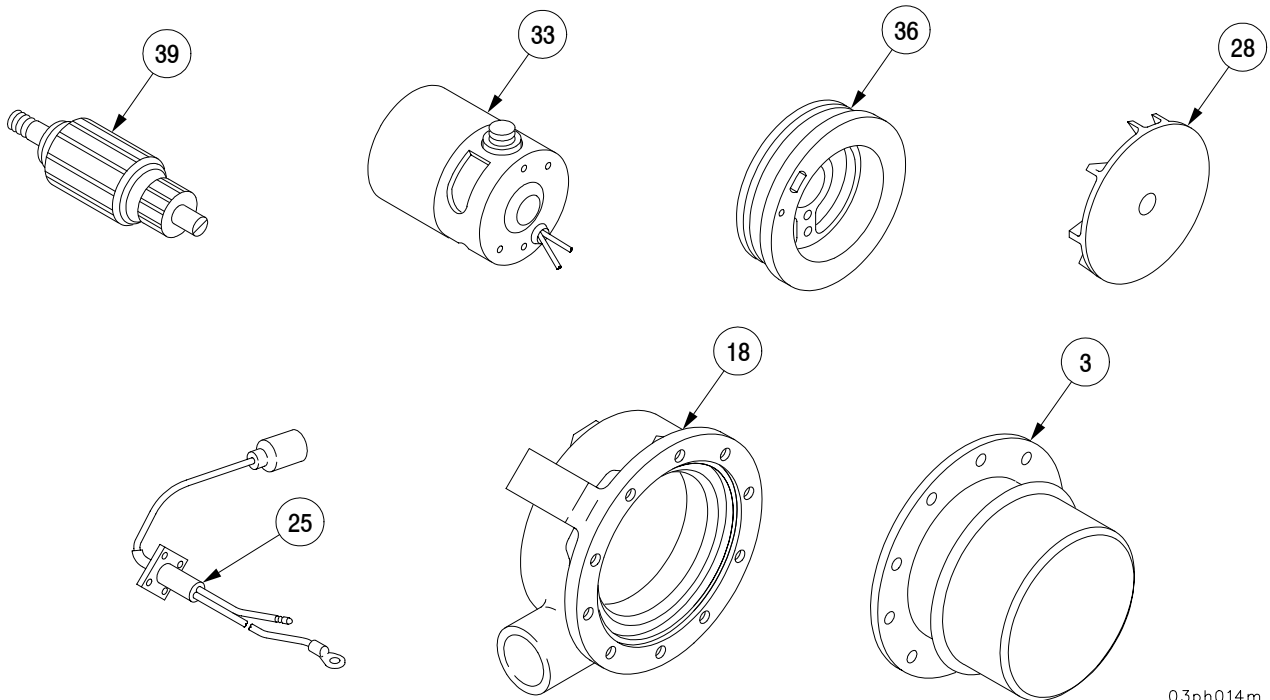

Section I. AIR CLEANER - CONTINUED

5-1 AIR CLEANER BLOWER ASSEMBLY - CONTINUED

c. Assembly.

- 1 Install new spacer (42) in end cap (36).
- 2 Install retainer (41) and two bearings (40) on armature (39).
- 3 Install armature (39) in end cap (36) with two new self-tapping screws (38) with captive lockwashers.
- 4 Install new spring washer (37) in stator assembly (33).
- 5 Install end cap (36) on stator assembly (33) with two screws (34) and two new lockwashers (35).
- 6 Install two brushes (32) in stator assembly (33) and secure two brushes (32) with two brush caps (31).
- 7 Install flat washer (30), flat washer (29), and impeller (28) on shaft of armature (39).
- 8 Secure impeller (28) to shaft of armature (39) with new self-locking nut (27) and flat washer (29).

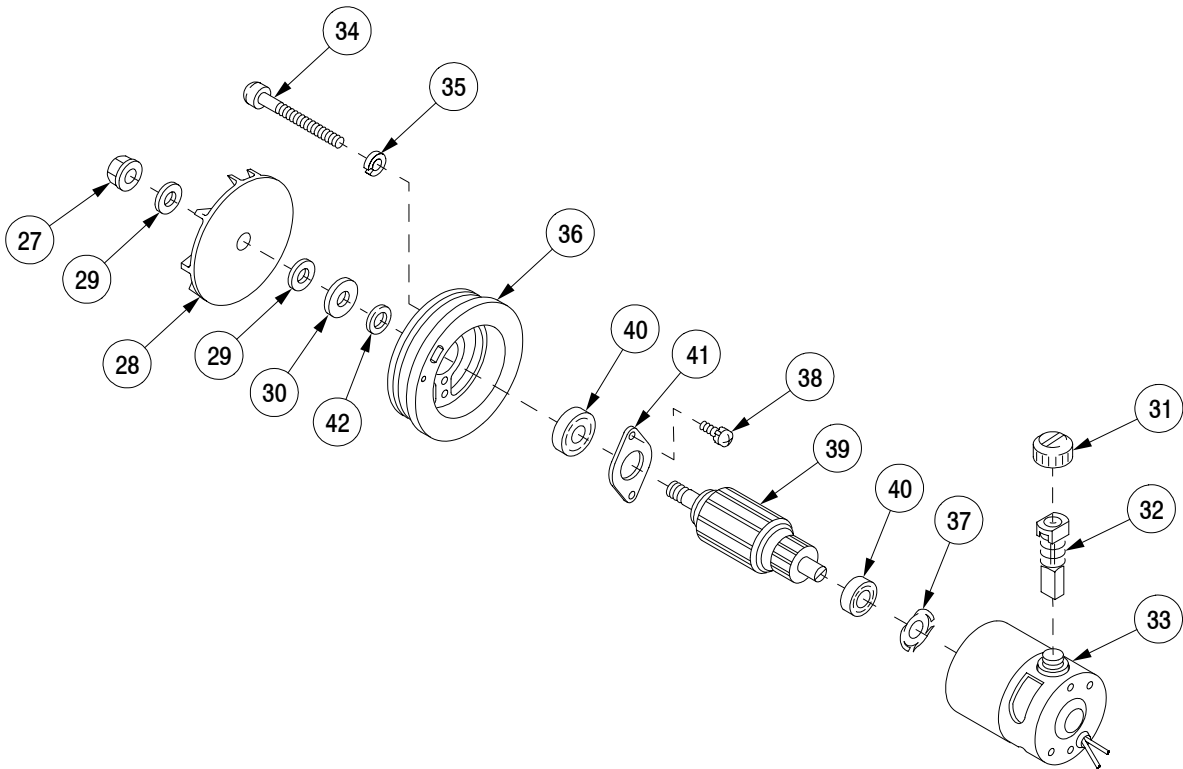

03ph013m

Section I. AIR CLEANER - CONTINUED

5-1 AIR CLEANER BLOWER ASSEMBLY - CONTINUED

c. Assembly - Continued

- 9 Install capacitor (25) and lead assembly with four screws (23), and four new lockwashers (24).
- 10 Install ground lead (21) and clip (22) on impeller housing (18) with screw (19) and new lockwasher (20).
- 11 Install new spring pin (26) in impeller housing (18).
- 12 Install motor assembly (15) with two new preformed packings (17) and (16) in impeller housing (18).

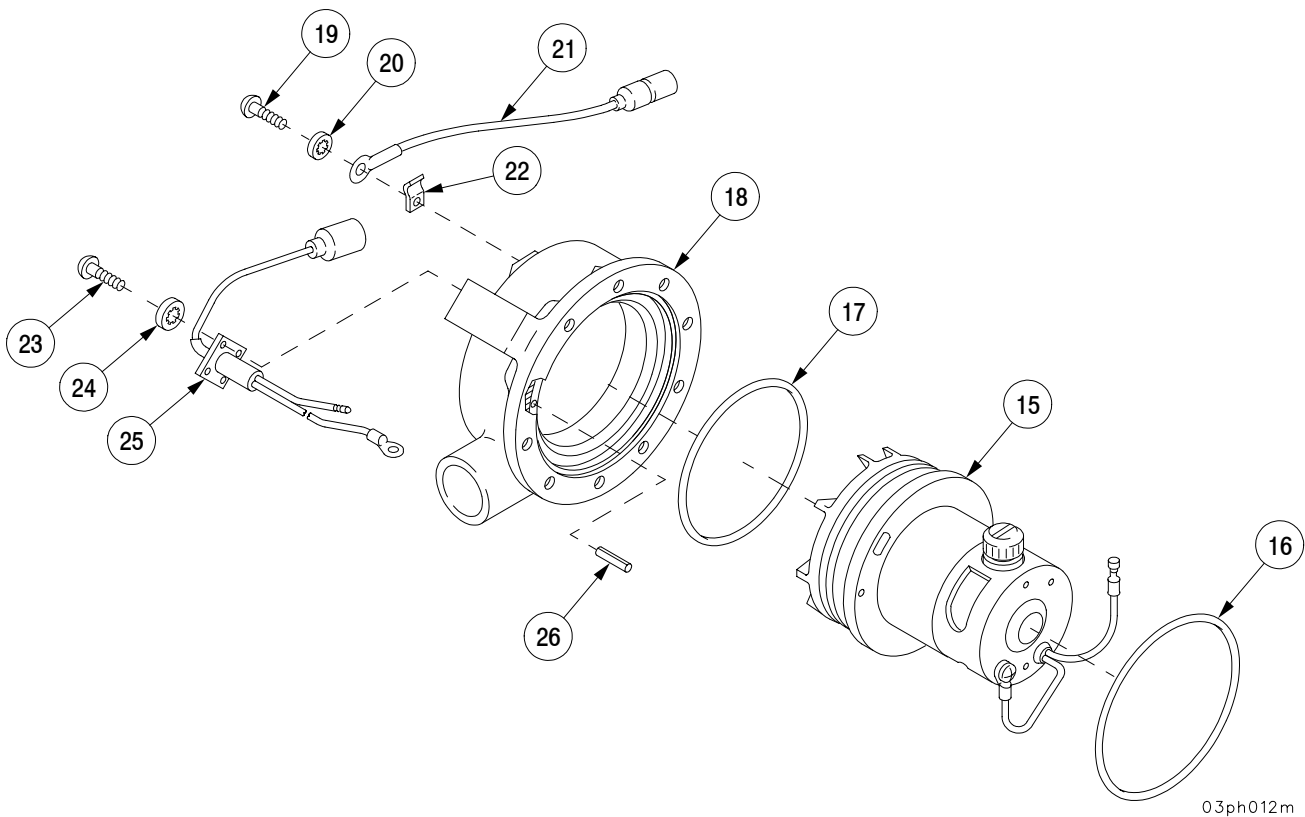

Section I. AIR CLEANER - CONTINUED

5-1 AIR CLEANER BLOWER ASSEMBLY - CONTINUED

c. Assembly - Continued

- 13 Secure capacitor ground lead (13) and motor ground lead (14) on end bell (7) with screw (11) and new lockwasher (12).
- 14 Install insulation sleeve (8) over motor lead connector (10). Connect motor lead (10) to capacitor electrical lead (9).
- 15 Slide insulation sleeve (8) over connection of capacitor electrical lead (9) and motor lead connector (10).
- 16 Install clip (6) over protective sleeve (8) and secure to end bell (7) with screw (4) and new lockwasher (5).
- 17 Perform test using 24 V dc power source.
- 18 Install motor cover (3) with 10 screws (1) and 10 new lockwashers (2).

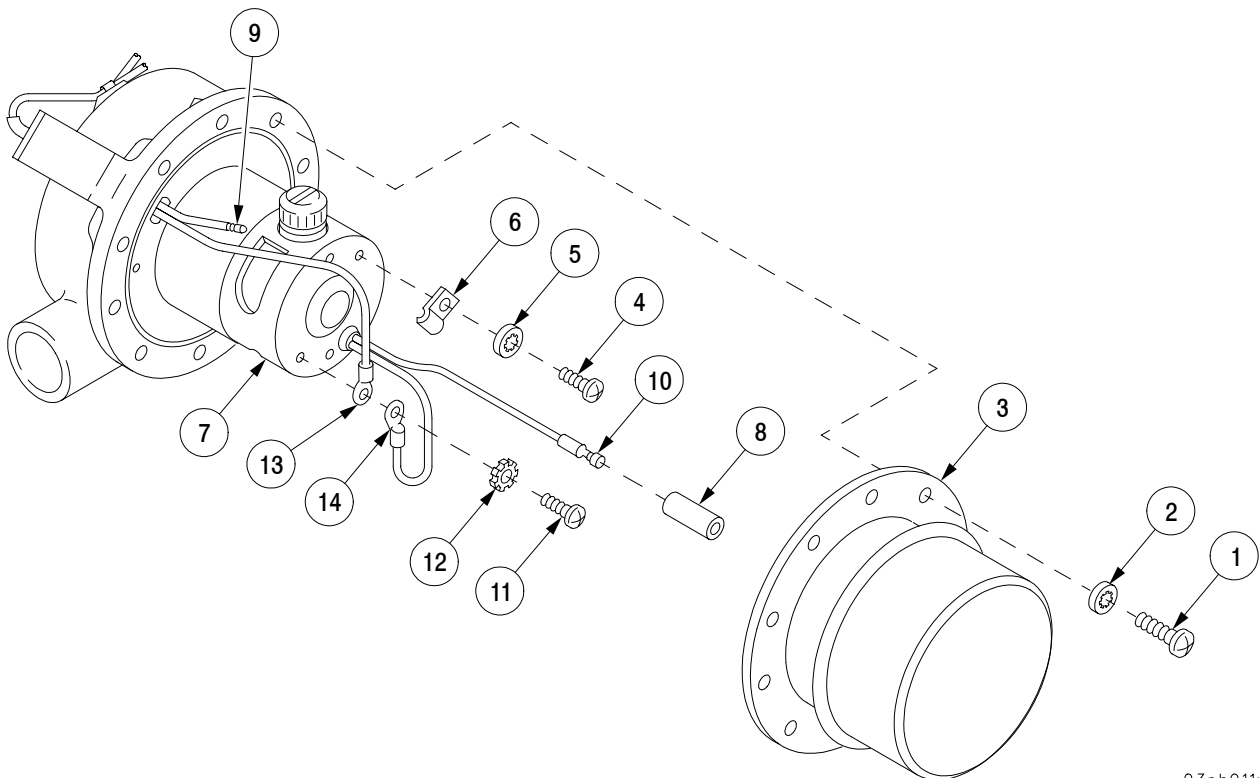

03ph011ma

Section II. TANKS, LINES, FITTINGS, AND HEADERS

5-2 FUEL TANKS.

This task covers: a. Removal b. Repair c. Installation

INITIAL SETUP

Tools

General mechanic's tool kit
(SC 5180-90-N26)
Torque wrench (item 57, Appx F)
Lifting sling (item 40, Appx F)
Suitable lifting device

Materials/Parts

Plastic repair kit (item 22, Appx B)
Repair kit (item 23, Appx B)
Dry-cleaning solvent (item 29, Appx B)
Sealing compound (item 25, Appx B)
Fire retardant paint (item 18, Appx B)

Equipment Conditions

Powerpack removed (TM 9-2350-314-20-1-1)
Fuel tanks drained (TM 9-2350-314-20-1-1)
Engine exhaust duct and outlet pipe
removed (lower fuel tank only)
(TM 9-2350-314-20-1-1)
Air cleaner duct and elbow removed
(lower fuel tank only) (TM 9-2350-314-20-1-1)
Exhaust heat shield removed (upper fuel
tank only) (TM 9-2350-314-20-1-1)
Fuel level transmitters removed
(TM 9-2350-314-20-1-1)
Fuel pumps removed (lower fuel tank only)
(TM 9-2350-314-20-1-1)
Filler assembly removed (upper fuel tank only)
(TM 9-2350-314-20-1-1)
Hoses, tubes, and fittings disconnected
(TM 9-2350-314-20-1-1)

Personnel Required

Three

References

TM 9-2350-314-20-1-1
TM 9-2350-314-10

Section II. TANKS, LINES, FITTINGS, AND HEADERS - CONTINUED

5-2 FUEL TANKS - CONTINUED

a. Removal.

WARNING

Do not smoke or use open flame when working on fuel systems. Fuel is highly combustible and explosion may occur resulting in possible severe injury.

- 1 Loosen turnbuckle (1).

NOTE

Quantity of flat washers (shims) will vary with strap location.

- 2 Remove two screws (2), flat washers (shims) (3), and retaining strap (4) from front of upper fuel tank (5).
- 3 Pull upper fuel tank (5) outward toward front of vehicle to clear hull recess and lift out of hull, using sling and suitable lifting device.

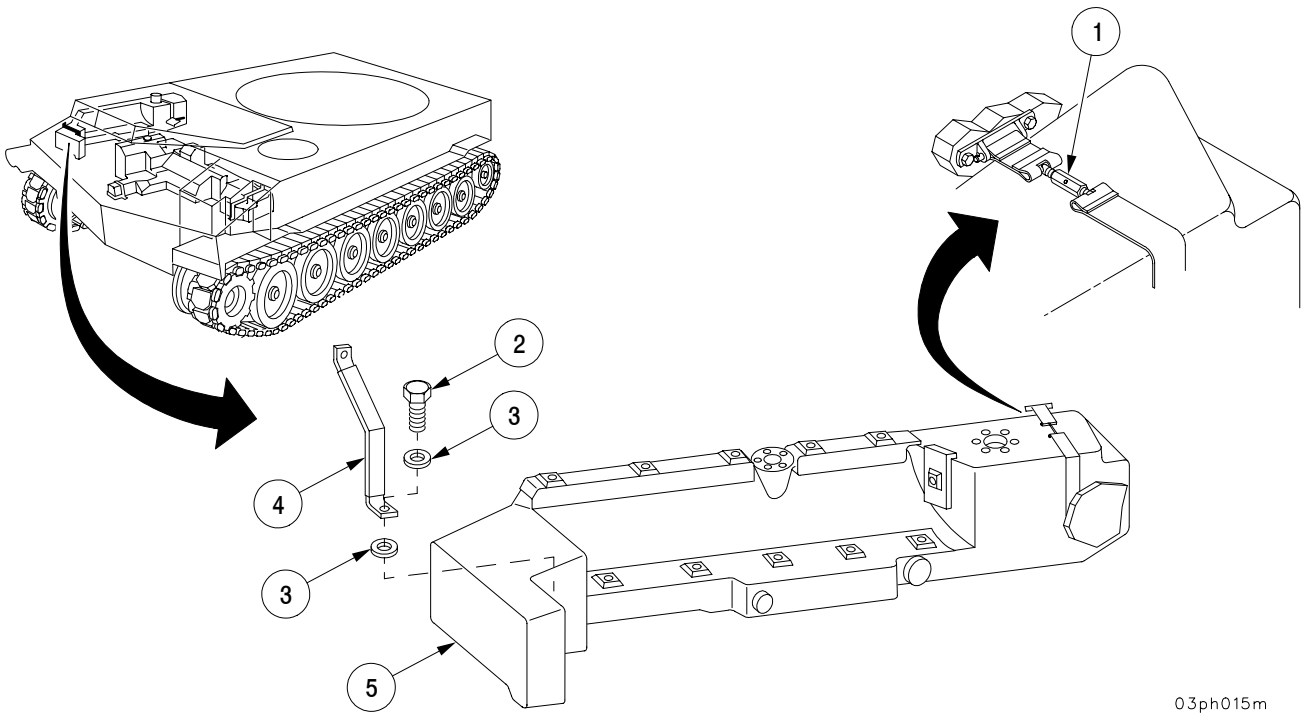

03ph015m

Section II. TANKS, LINES, FITTINGS, AND HEADERS - CONTINUED

5-2 FUEL TANKS - CONTINUED

a. Removal - Continued

- 4 Disconnect hose (6) from elbow (7).
- 5 Remove screw (8) and clamp (9) securing hose (6) to hull.

NOTE

- Quantity of flat washers (shims) will vary with strap location.
 - Length of screws will vary with the quantity of flat washers (shims) used.
- 6 Remove four screws (10), flat washers (shims) (11), and three retaining straps (12, 13, and 14).
 - 7 Lift lower fuel tank (15) over engine mount assembly (16), attach sling and remove from vehicle using suitable lifting device.
 - 8 Remove hose (6) from elbow (17).
 - 9 Remove elbow (17) from lower fuel tank (15).

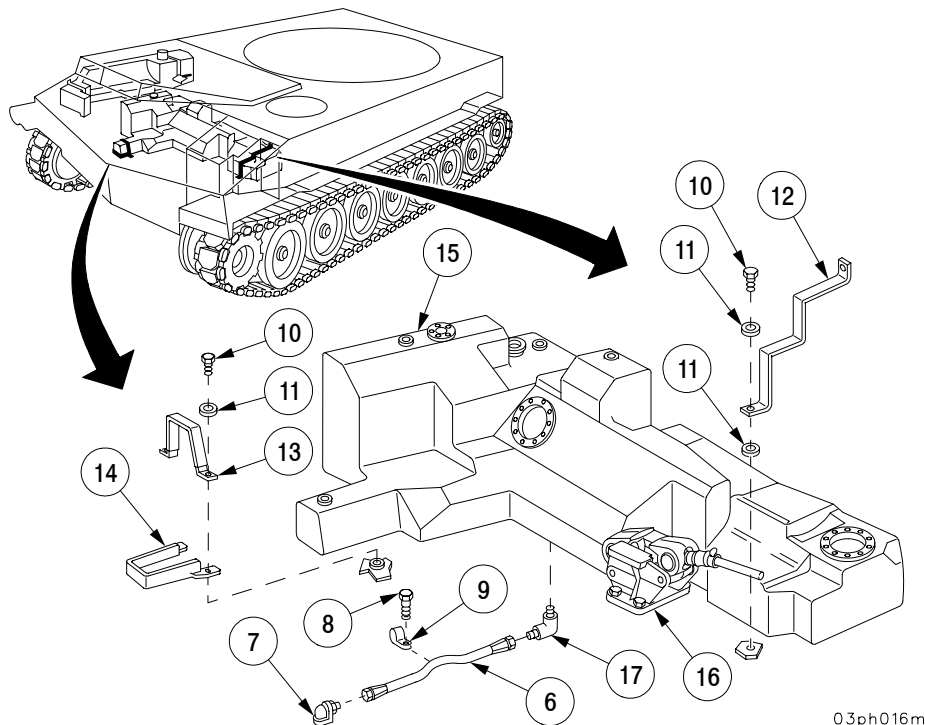

Section II. TANKS, LINES, FITTINGS, AND HEADERS - CONTINUED

5-2 FUEL TANKS - CONTINUED

b. Repair.

WARNING

Immediately after working with fiberglass and resin, thoroughly wash any exposed skin surfaces. If fiber particles are embedded in the skin, DO NOT SCRUB - RINSE IN WARM SOAPY WATER AND SEEK MEDICAL ASSISTANCE.

FUEL TANK CONSTRUCTION

The fuel tanks are constructed of fiberglass, which is formed of laminated sheets of glass cloth held together with synthetic resin. When the liquid resin cures (hardens), it binds together the filaments of glass in the cloth to create a solid panel. The strength of the panel is provided by the glass fiber while the resin acts merely as a bonding agent, supplying only limited additional strength to the panel. Damaged sections in reinforced fiberglass tanks can be repaired by patching with materials contained in repair kits.

WARNING

No smoking or open flames during fuel tank repair. Wear respirator and rubberized protective clothing when working on fiberglass. Fiberglass inhalation can cause severe respiratory problems. Fiberglass particles embedded in the skin will cause irritation and possible infection.

NOTE

- For major repairs, 1 in. (25 mm) or larger, use repair kit (item 21, Appx B).
- For minor repairs, 1 in. (25 mm) or smaller, use repair kit (item 22, Appx B).
- Applying fiberglass and epoxy repair materials in a cold shop retards curing.

Section II. TANKS, LINES, FITTINGS, AND HEADERS - CONTINUED

5-2 FUEL TANKS - CONTINUED

b. Repair - Continued**NOTE**

- To repair holes larger than 1 in. (25 mm) across, follow steps 1 thru 20. To repair cracks or punctures smaller than 1 in. (25 mm) across (or in length), follow steps 2 thru 4 and 21 thru 25.
 - Repair procedures apply to both upper and lower fuel tanks.
- 1 For holes larger than 1 in. (25 mm) across at any point, cut away damaged area. Make a smooth edged circular opening, as sharp angular cuts add to the difficulty of repair.
 - 2 Scarf a crater with at least 1-1/2 in. (38 mm) sloping sides, down to opening.

WARNING

Dry-cleaning solvent (P-D-680), used to clean parts, is toxic and flammable. Wear protective goggles and gloves and use only in a well-ventilated area. Avoid contact with skin, eyes, and clothes. Do not breathe vapors. Do not use near open flame or excessive heat. Do not smoke when using solvent. Failure to do so could cause **SERIOUS INJURY**. If you become dizzy while using dry-cleaning solvent, get fresh air immediately, and if necessary, get medical attention. If contact with skin or clothes is made, flush thoroughly with water. If the solvent contacts your eyes, wash them with water immediately and obtain medical aid (ref. FM 21-11).

- 3 Remove dust and clean repair area with dry-cleaning solvent.

NOTE

The presence of oil in the repair area will result in poor adhesion.

- 4 Use 1/8 in. (3 mm) application of regenerated silica compacted under a warm pad to withdraw oil for improved adhesion.

Section II. TANKS, LINES, FITTINGS, AND HEADERS - CONTINUED

5-2 FUEL TANKS - CONTINUED

b. Repair - Continued

- 5 Measure repair area and estimate material requirement.

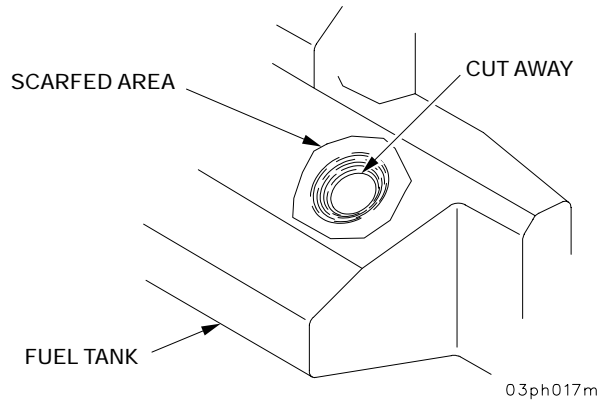

NOTE

If damaged area is near an opening in the tank, apply a backing plate with masking tape and release film, rather than using the cloth wire.

- 6 Cut and trim a piece of wire screen slightly larger than opening. If opening is less than 1 in. (25 mm) across at greatest point, wire screen is not required.
- 7 Cut glass cloth patches to size and shape. Cut first patch 1/2 in. (12 mm) larger than opening until sufficient cloth has been built up to level the patched area with the surrounding tank wall (usually six or seven patches).
- 8 Mix resin and hardener as directed on can label.
- 9 Thoroughly saturate scarfed area and wire screen with cement and apply screen over opening.
- 10 Remove about 1/5 of the cement from the mixing container. Fold in a small amount of regenerated silica to obtain a putty-like consistency. Use this mixture to apply the first two layers of glass cloth.
- 11 Thoroughly saturate the smallest glass cloth with the putty-like cement and place it over the screen.

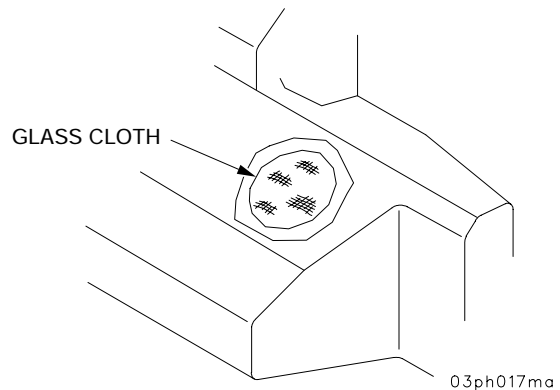
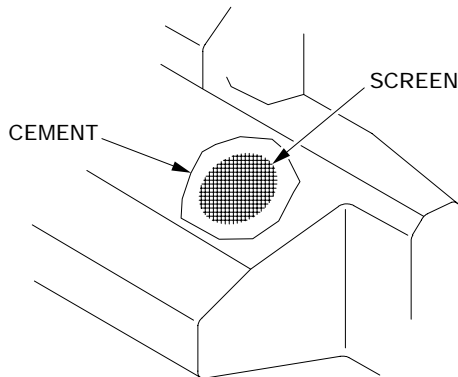

Section II. TANKS, LINES, FITTINGS, AND HEADERS - CONTINUED

5-2 FUEL TANKS - CONTINUED

b. Repair - Continued**NOTE**

Apply release film and work out air pockets after each lamination. Work from center of patch outward.

- 12 Place a piece of release film on the patch and, with a hardwood depressor, work out air pockets. Work from center of patch outward.

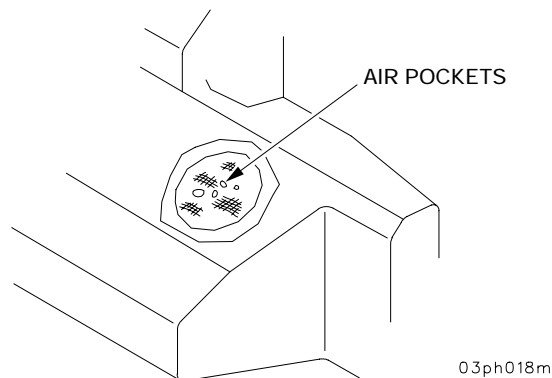

- 13 Remove release film.
14 Repeat this procedure for application of the second patch.
15 Saturate remaining patches with mixture without silica and apply to crater.
16 Allow completed patch to set undisturbed for 16 to 24 hours.

NOTE

Cure will be slow in temperatures below 70°F (21°C); however, during the first hour of cure, temperature should not exceed 100°F (38°C).

- 17 To expedite cure to about 4 hours, place a heat lamp over patch and gradually increase intensity. Keep lamp at least 2 ft. (0.6 m) away from patch and do not allow temperature to exceed 250°F (121°C).

Section II. TANKS, LINES, FITTINGS, AND HEADERS - CONTINUED

5-2 FUEL TANKS - CONTINUED

b. Repair - Continued

WARNING

Dry-cleaning solvent (P-D-680), used to clean parts, is toxic and flammable. Wear protective goggles and gloves and use only in a well-ventilated area. Avoid contact with skin, eyes, and clothes. Do not breathe vapors. Do not use near open flame or excessive heat. Do not smoke when using solvent. Failure to do so could cause SERIOUS INJURY. If you become dizzy while using dry-cleaning solvent, get fresh air immediately, and if necessary, get medical attention. If contact with skin or clothes is made, flush thoroughly with water. If the solvent contacts your eyes, wash them with water immediately and obtain medical aid (ref. FM 21-11).

- 18 When cure is complete, sand patch flush with surrounding surface. Clean with dry-cleaning solvent and paint with fire retardant paint.

WARNING

- Wear protective goggles or face shield when using compressed air. Particles blown by compressed air are hazardous and could cause injury.
- Compressed air used for cleaning purposes will not exceed 30 psi (207 kPa). Use only with effective chip guarding and personal protective equipment (goggles/shield, gloves, etc.).

- 19 Pressure test repaired tank using low pressure compressed air at 3 psi (21 kPa).
- 20 Thoroughly flush tank and dry with low pressure compressed air.

Section II. TANKS, LINES, FITTINGS, AND HEADERS - CONTINUED

5-2 FUEL TANKS - CONTINUED

b. Repair - Continued

- 21 Mix sufficient cement to cover the hole by following instructions on the cement can. Apply cement directly to the puncture or crack (fill in entire scarfed area).

NOTE

A small amount of regenerated silica may be mixed with cement for added consistency if desired.

- 22 Allow patch to cure 16 to 24 hours.

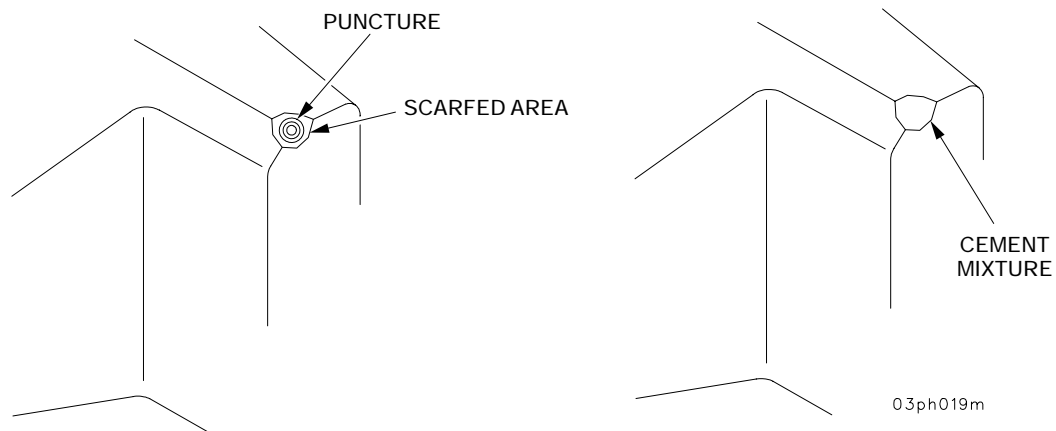
**WARNING**

- Wear protective goggles or face shield when using compressed air. Particles blown by compressed air are hazardous and could cause injury.
- Compressed air used for cleaning purposes will not exceed 30 psi (207 kPa). Use only with effective chip guarding and personal protective equipment (goggles/shield, gloves, etc.)

- 23 Pressure test, flush, and dry repaired tank using low pressure compressed air at 3 psi (21 kPa).

Section II. TANKS, LINES, FITTINGS, AND HEADERS - CONTINUED

5-2 FUEL TANKS - CONTINUED

b. Repair - Continued

- 24 Thoroughly flush tank and dry with low pressure compressed air.

WARNING

Dry-cleaning solvent (P-D-680), used to clean parts, is toxic and flammable. Wear protective goggles and gloves and use only in a well-ventilated area. Avoid contact with skin, eyes, and clothes. Do not breathe vapors. Do not use near open flame or excessive heat. Do not smoke when using solvent. Failure to do so could cause **SERIOUS INJURY**. If you become dizzy while using dry-cleaning solvent, get fresh air immediately, and if necessary, get medical attention. If contact with skin or clothes is made, flush thoroughly with water. If the solvent contacts your eyes, wash them with water immediately and obtain medical aid (ref. FM 21-11).

- 25 Sand patch smooth, clean with dry-cleaning solvent, and paint with fire retardant paint.

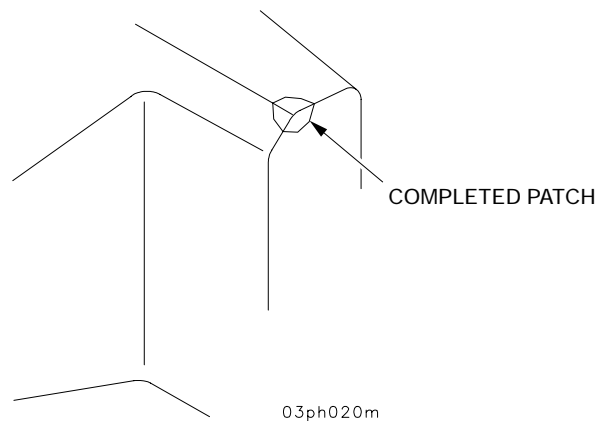

Section II. TANKS, LINES, FITTINGS, AND HEADERS - CONTINUED

5-2 FUEL TANKS - CONTINUED

c. Installation

- 1 Install elbow (17) on lower fuel tank (15).
- 2 Install hose (6) on elbow (17).

NOTE

- Prior to installing fuel tanks, perform required repairs on associated components (retaining strap, turnbuckle, and pads).
 - Fuel tanks vary in exterior dimensions and shape.
- 3 Install lower fuel tank (15) in position behind engine mount assembly (16), using sling and suitable lifting device.

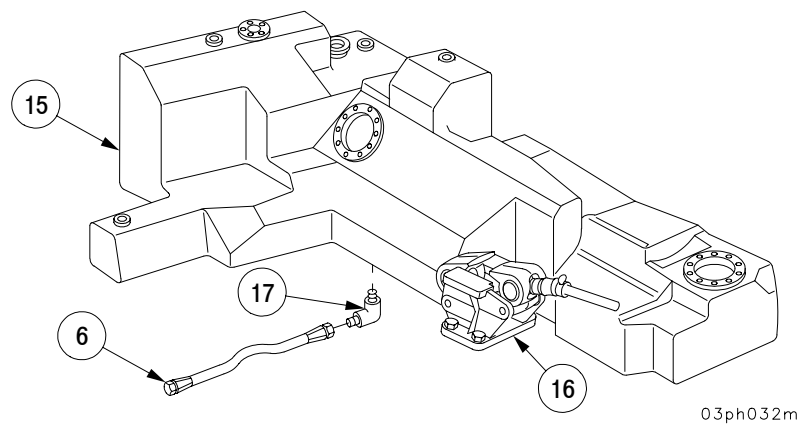
**NOTE**

- Apply sealing compound to screws prior to installation.
- If space exists between lower fuel tank and retaining strap, a pad is required.
- Flat washers (shims) are installed to prevent rocking or shifting of fuel tank.
- Flat washers (shims) are installed between fuel tank and mounting pads.
- Do not bond flat washers (shims).

Section II. TANKS, LINES, FITTINGS, AND HEADERS - CONTINUED

5-2 FUEL TANKS - CONTINUED

c. Installation - Continued

NOTE

- Length of screws and quantity of flat washers (shims) will vary with strap location. Use enough flat washers (shims) to obtain metal-to-metal contact between strap and hull. Strap must be snug without squeezing fuel tanks.
- If quantity of flat washers (shims) is three or less, use short length screw. If quantity of flat washers (shims) is more than three, use longer length screw.

- 4 Install two retaining straps (13 and 14) in engine compartment with two screws (10) and flat washers (shims) (11).
- 5 Measure gap between retaining strap (13) and top of lower fuel tank (15). If gap is greater than 3/16 in. (5 mm), position strap (14) under strap (13), then reinstall screw (10) and flat washers (shims) (11).
- 6 Install retaining strap (12) in engine compartment with two screws (10) and flat washers (shims) (11).
- 7 Secure hose (6) to hull with clamp (9) and screw (8).
- 8 Connect hose (6) to elbow (7).

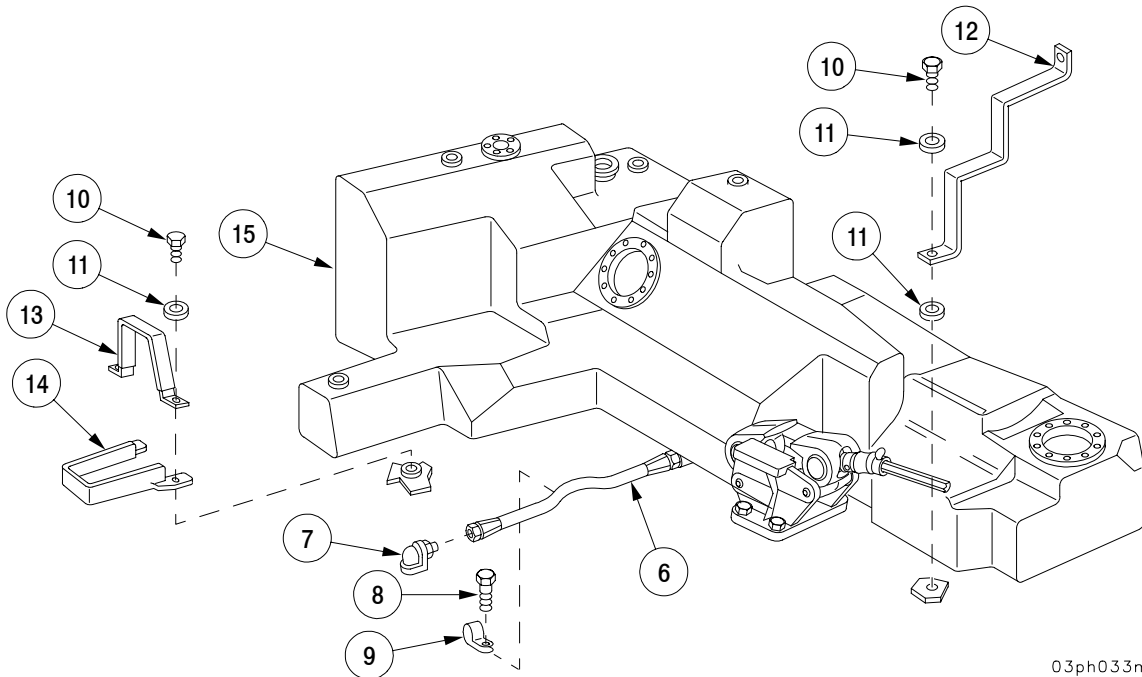

03ph033m

Section II. TANKS, LINES, FITTINGS, AND HEADERS - CONTINUED

5-2 FUEL TANKS - CONTINUED

c. Installation - Continued**NOTE**

Nut and screw are accessed from inside crew compartment.

- 9 Loosen nut (18), turn screw (19), and retract channel (20) towards bulkhead (21).
- 10 Install upper fuel tank (5) in engine compartment using sling and suitable lifting device. Push fuel tank (5) towards rear of vehicle.
- 11 Check position of upper fuel tank (5), for proper alignment of crossover tube and filler assembly. Reposition fuel tank (5) if required.

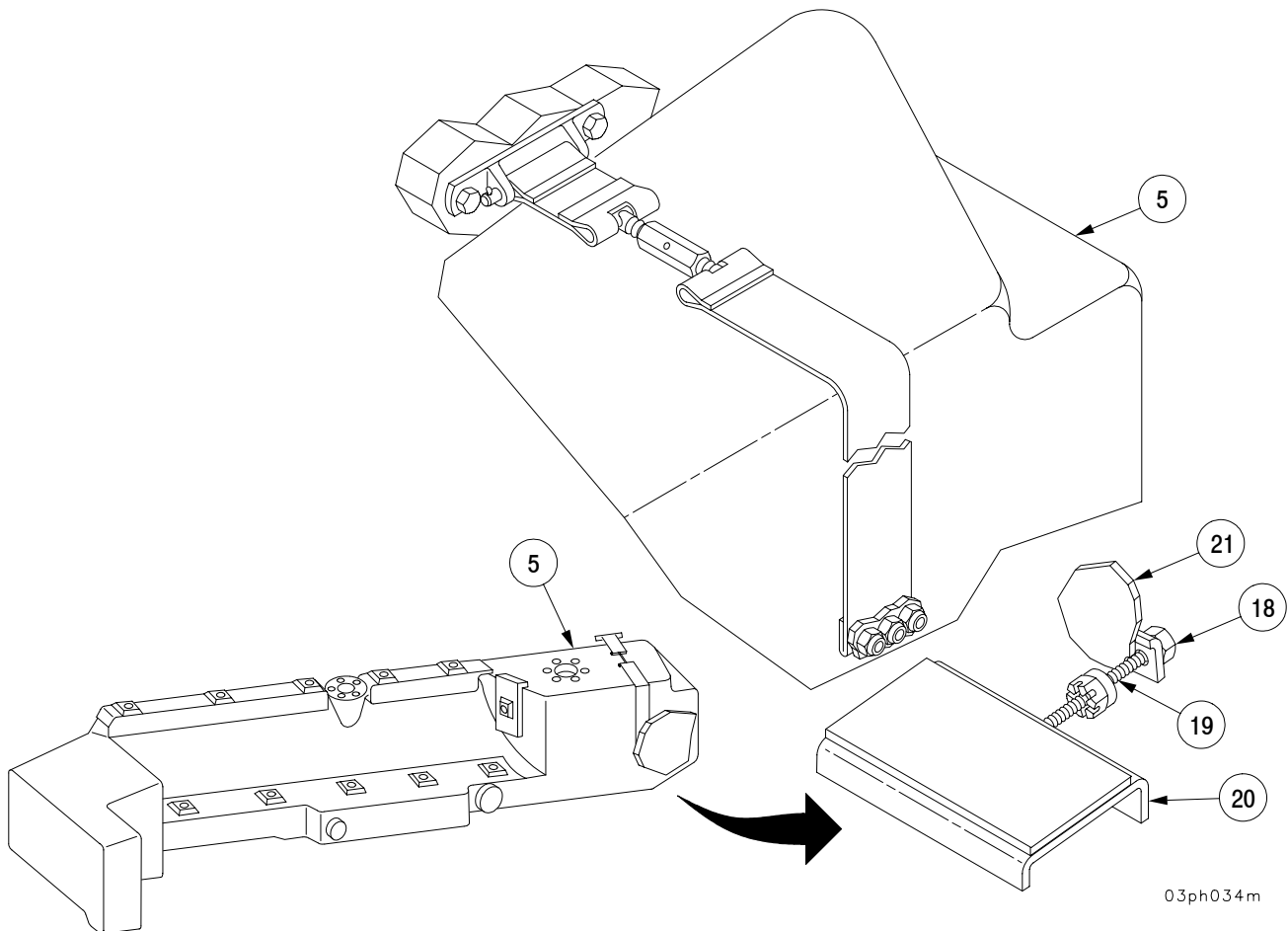

Section II. TANKS, LINES, FITTINGS, AND HEADERS - CONTINUED

5-2 FUEL TANKS - CONTINUED

c. Installation - Continued

NOTE

If snug fit between strap and upper fuel tank is not obtained, add flat washers (shims) between strap and hull.

- 12 Install retaining strap (4) in engine compartment with two screws (2) and flat washers (shims) (3).
- 13 Tighten turnbuckle (1).

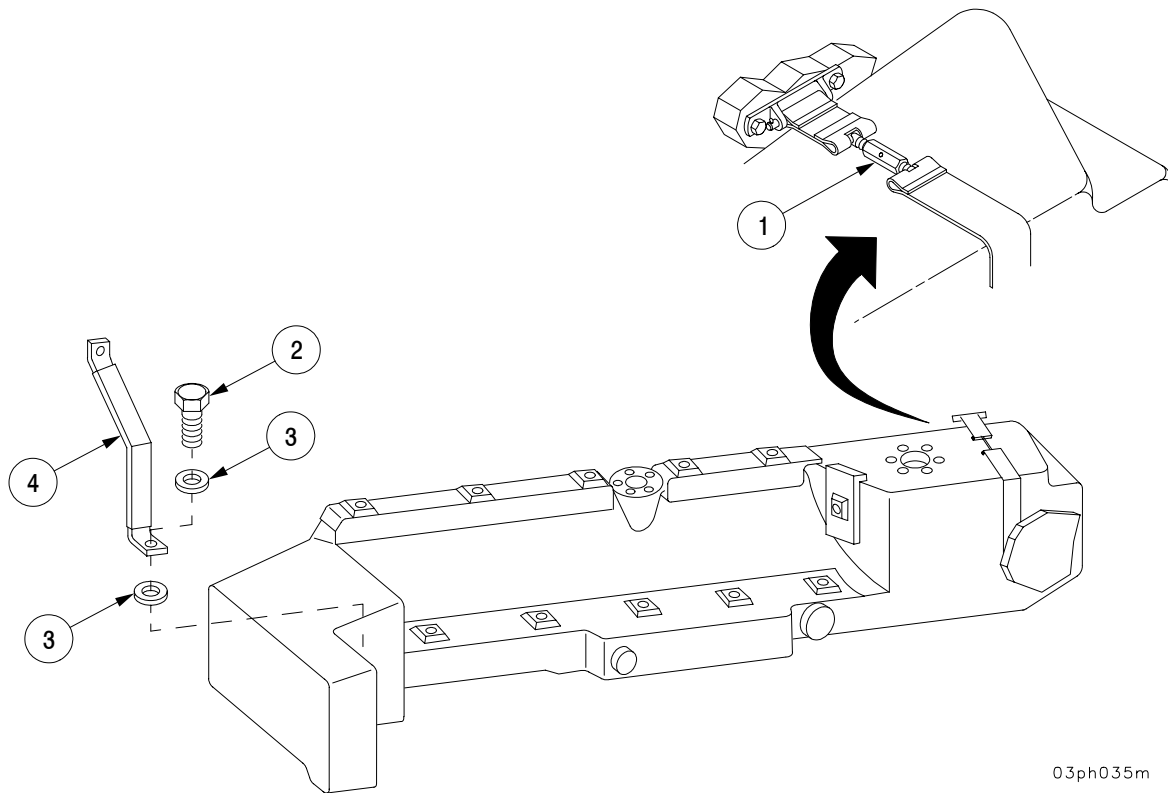

03ph035m

Section II. TANKS, LINES, FITTINGS, AND HEADERS - CONTINUED

5-2 FUEL TANKS - CONTINUED

c. Installation - Continued

- 14 Extend channel (20) against upper fuel tank (5) with screw (19) and nut (18). Torque nut to 10 lb-ft (13 N·m).

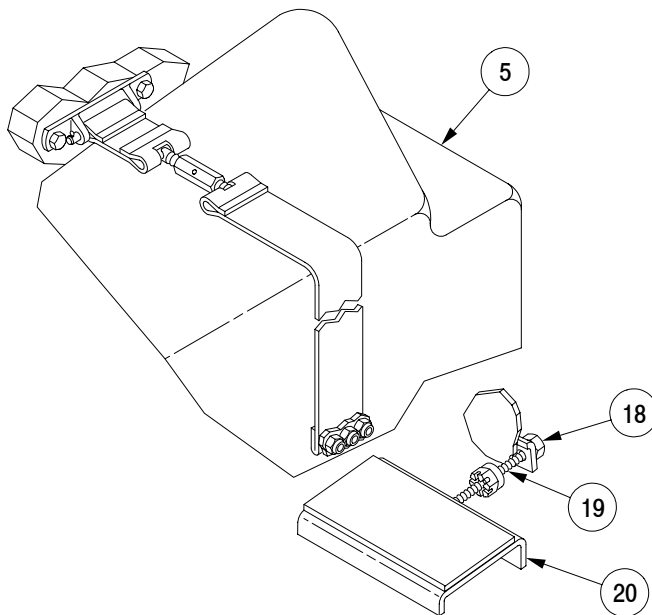

03ph036m

NOTE**FOLLOW-ON MAINTENANCE:**

- Install hoses, tubes, and fittings
(TM 9-2350-314-20-1-1)
- Install filler assembly (upper tank only)
(TM 9-2350-314-20-1-1)
- Install fuel pumps (lower tank only)
(TM 9-2350-314-20-1-1)
- Install fuel level transmitters
(TM 9-2350-314-20-1-1)
- Install exhaust heat shield (upper tank only)
(TM 9-2350-314-20-1-1)
- Install air cleaner duct and elbow (lower tank only)
(TM 9-2350-314-20-1-1)
- Install engine exhaust duct and outlet pipe (lower tank only)
(TM 9-2350-314-20-1-1)
- Install powerpack (TM 9-2350-314-20-1-1)
- Refuel vehicle (TM 9-2350-314-10)

Section II. TANKS, LINES, FITTINGS, AND HEADERS - CONTINUED

5-3 FUEL TANK PADS AND HULL-MOUNTED PADS.

This task covers: a. Removal b. Installation

INITIAL SETUP

Tools

General mechanic's tool kit
(SC 5180-90-N26)
Wire brush (item 8, Appx F)

Materials/Parts

Adhesive (item 1, Appx B)
Dry-cleaning solvent (item 29, Appx B)
Acid swabbing brush (item 6, Appx B)

Equipment Conditions

Fuel tanks removed (para 5-2)

a. Removal.

NOTE

- Remove only those pads that are defective and need replacement.
- Configuration may vary between vehicles.

1 Remove hull-mounted pads (1) and/or fuel tank pads (2).

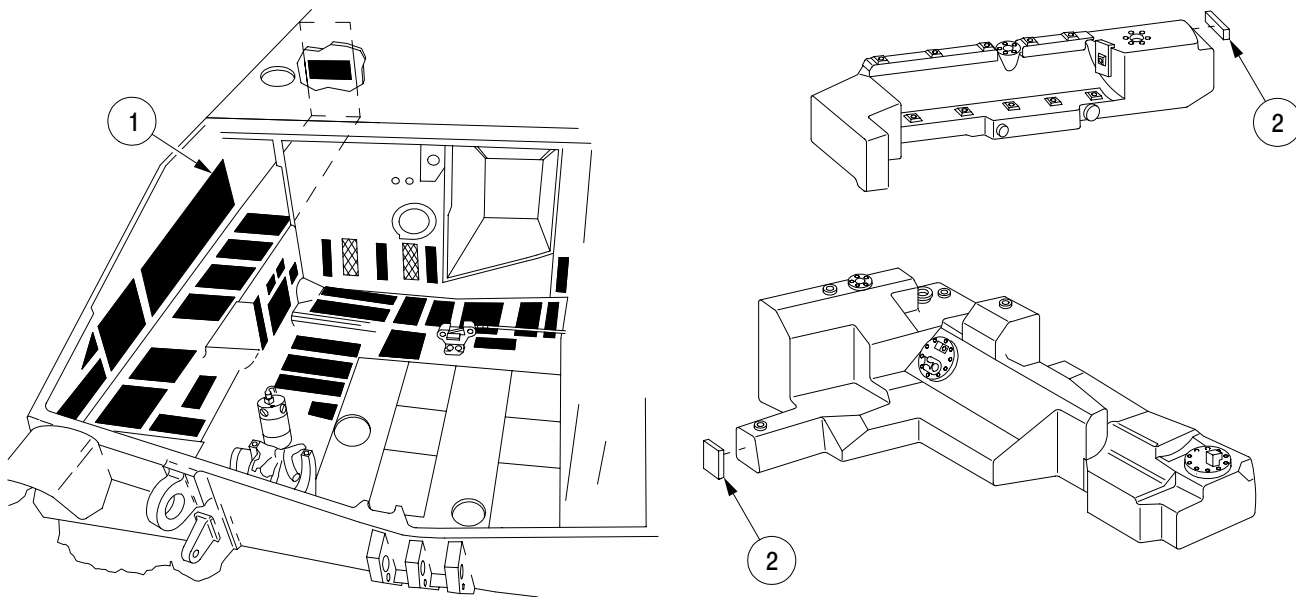

03ph026m

Section II. TANKS, LINES, FITTINGS, AND HEADERS - CONTINUED

5-3 FUEL TANK PADS AND HULL-MOUNTED PADS - CONTINUED

a. Removal - Continued**WARNING**

Dry-cleaning solvent (P-D-680), used to clean parts, is toxic and flammable. Wear protective goggles and gloves and use only in a well-ventilated area. Avoid contact with skin, eyes, and clothes. Do not breathe vapors. Do not use near open flame or excessive heat. Do not smoke when using solvent. Failure to do so could cause **SERIOUS INJURY**. If you become dizzy while using dry-cleaning solvent, get fresh air immediately, and if necessary, get medical attention. If contact with skin or clothes is made, flush thoroughly with water. If the solvent contacts your eyes, wash them with water immediately and obtain medical aid (ref. FM 21-11).

- 2 Clean pad mounting surfaces with dry-cleaning solvent and wire brush.

b. Installation.**NOTE**

Pads may require cutting and/or laminating to achieve required size and thickness. Laminate pads with adhesive as required.

- 1 Apply adhesive to fuel tank pads (2) and/or hull-mounted pads (1) and pad mounting surfaces using acid brush.
- 2 Install fuel tank pads (2) and/or hull-mounted pads (1).

NOTE

FOLLOW-ON MAINTENANCE:
Install fuel tanks (para 5-2)

Section II. TANKS, LINES, FITTINGS, AND HEADERS - CONTINUED

5-4 FUEL TANK MOUNTING PLATE AND RETAINING BAND

This task covers:

a. Removal	b. Disassembly
c. Assembly	d. Installation

INITIAL SETUP

Tools

General mechanic's tool kit
(SC 5180-90-N26)
Wire brush (item 8, Appx F)
Torque wrench (item 57, Appx F)

Equipment Conditions

Upper fuel tank removed (para 5-2)

Materials/Parts

Adhesive (item 1, Appx B)
Sealing compound (item 25, Appx B)
Dry-cleaning solvent (item 29, Appx B)
Acid swabbing brush (item 6, Appx B)
Cotter pin (item 52, Appx E)
Spring pin (item 43, Appx E)
Self-locking nuts (3) (item 34, Appx E)
Cushioning pad (item 6, Appx E)

NOTE

- Perform Removal steps 1 thru 3, Disassembly steps 1 and 2, Assembly steps 1 and 6 thru 8, and Installation steps 3 thru 6 for maintenance of fuel tank retaining band.
- Perform Removal steps 4 and 5, Disassembly steps 3 and 4, Assembly steps 2 thru 5, and Installation steps 1 and 2 for maintenance of mounting plate.

Section II. TANKS, LINES, FITTINGS, AND HEADERS - CONTINUED

5-4 FUEL TANK MOUNTING PLATE AND RETAINING BAND - CONTINUED

a. Removal.

- 1 Remove cotter pin (1) and headed pin (2) from bracket (3). Discard cotter pin.
- 2 Remove three screws (4), three self-locking nuts (5), and three flat washers (shims) (6) securing rear retaining band assembly (7) to hull. Discard self-locking nuts.
- 3 Remove two screws (8) and bracket (3).

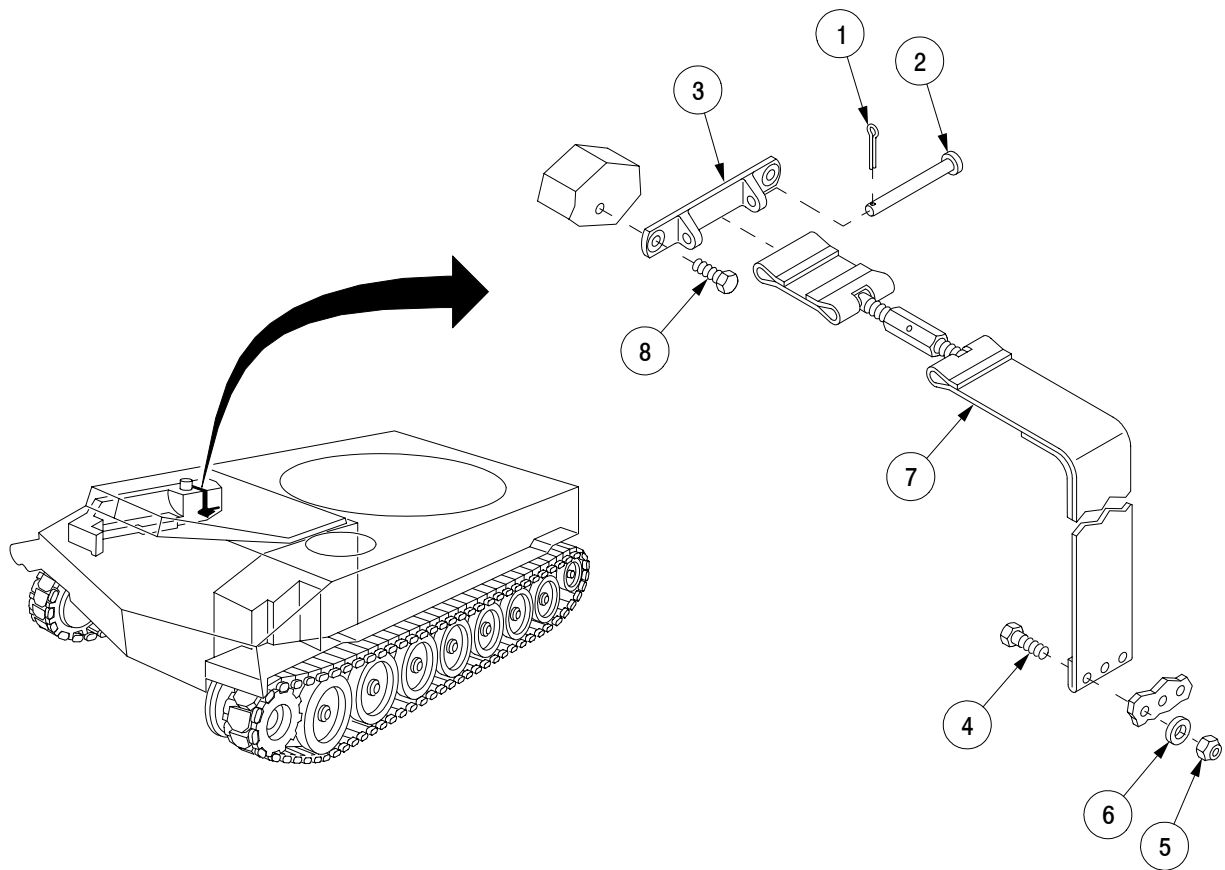

03ph027m

Section II. TANKS, LINES, FITTINGS, AND HEADERS - CONTINUED

5-4 FUEL TANK MOUNTING PLATE AND RETAINING BAND - CONTINUED

a. Removal - Continued

NOTE

Nut and retainer are located inside hull crew compartment at forward bulkhead.

- 4 Remove nut (9) and retainer (10).
- 5 Remove mounting plate (11) with stud (12), nut (13), and flat washer (14) from hull recess in engine compartment.

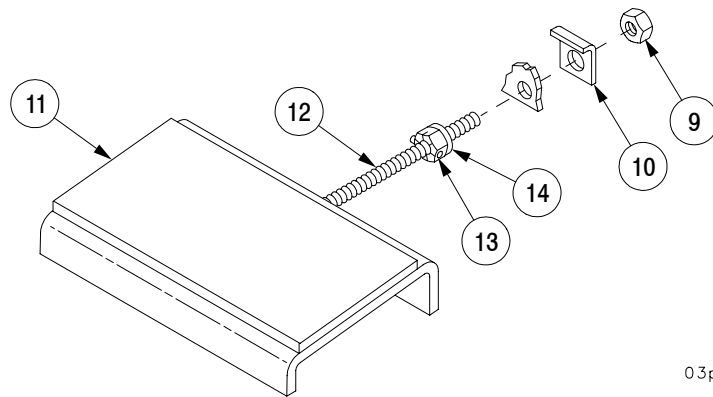

03ph028m

b. Disassembly.

- 1 Separate top retaining band (15), side retaining band (16), and turnbuckle (17).
- 2 Remove cushioning pad (18) from side retaining band (16). Discard cushioning pad.
- 3 Remove stud (12) from mounting plate (11).
- 4 Remove flat washer (14), spring pin (19), and nut (13) from stud (12). Discard spring pin.

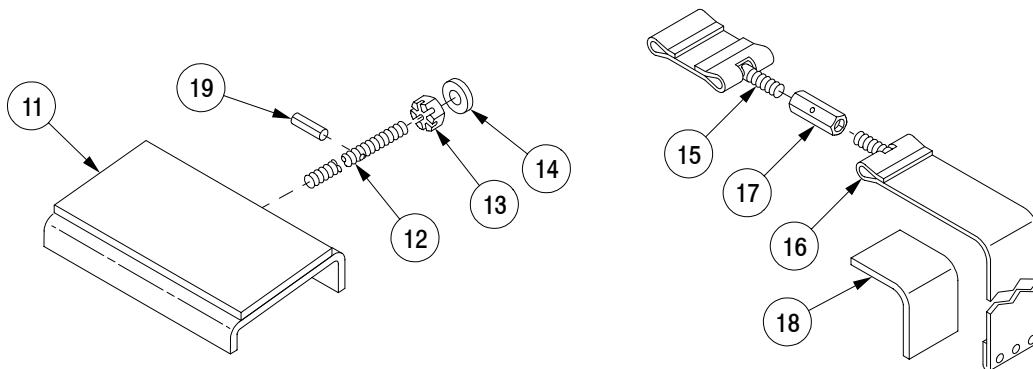

03ph029m

Section II. TANKS, LINES, FITTINGS, AND HEADERS - CONTINUED

5-4 FUEL TANK MOUNTING PLATE AND RETAINING BAND - CONTINUED

c. Assembly.

WARNING

Dry-cleaning solvent (P-D-680), used to clean parts, is toxic and flammable. Wear protective goggles and gloves and use only in a well-ventilated area. Avoid contact with skin, eyes, and clothes. Do not breathe vapors. Do not use near open flame or excessive heat. Do not smoke when using solvent. Failure to do so could cause **SERIOUS INJURY**. If you become dizzy while using dry-cleaning solvent, get fresh air immediately, and if necessary, get medical attention. If contact with skin or clothes is made, flush thoroughly with water. If the solvent contacts your eyes, wash them with water immediately and obtain medical aid (ref. FM 21-11).

- 1 Clean side retaining band (16) using dry-cleaning solvent and wire brush.
- 2 Install nut (13) on stud (12).
- 3 Install new spring pin (19) in stud (12).
- 4 Install flat washer (14) on stud (12).
- 5 Install stud (12) in mounting plate (11).
- 6 Apply adhesive to new cushioning pad (18) using acid brush.
- 7 Install new cushioning pad (18) on side retaining band (16).
- 8 Install side retaining band (16) and top retaining band (15) in turnbuckle (17).

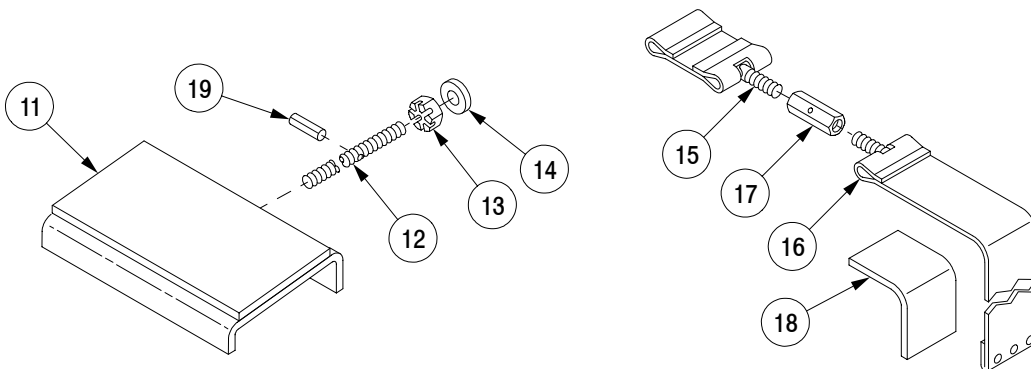

03ph029m

Section II. TANKS, LINES, FITTINGS, AND HEADERS - CONTINUED

5-4 FUEL TANK MOUNTING PLATE AND RETAINING BAND - CONTINUED

d. Installation.

- 1 Install mounting plate (11) with stud (12), nut (13), and flat washer (14) in hull recess of engine compartment.

NOTE

Prior to fuel tank installation, retract mounting plate.
After fuel tank installation, extend mounting plate.

- 2 Install retainer (10) and nut (9) from inside of hull crew compartment. Torque nut to 10 lb-ft (13 N·m).

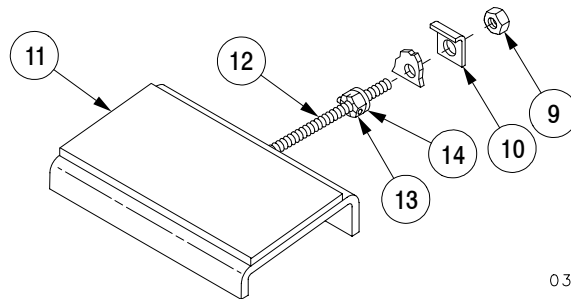

03ph030m

- 3 Apply sealing compound to two screws (8).
- 4 Install bracket (3) with two screws (8).
- 5 Install rear retaining band assembly (7) in bracket (3) with headed pin (2) and new cotter pin (1).
- 6 Install rear retaining band assembly (7) to hull with three screws (4), three flat washers (shims) (6), and three new self-locking nuts (5).

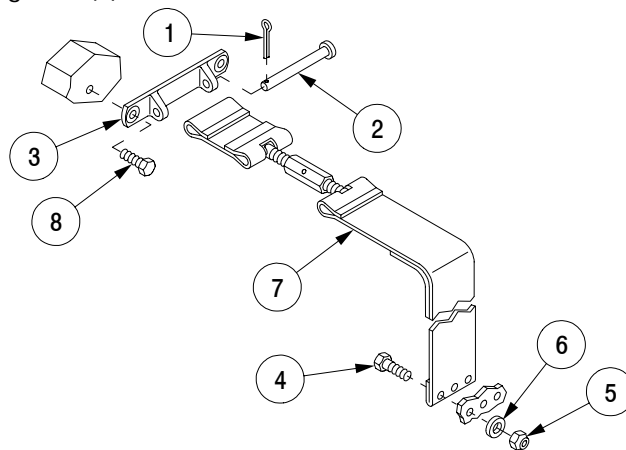

03ph031m

NOTE

FOLLOW-ON MAINTENANCE:

Install upper fuel tank (para 5-2)

CHAPTER 6 COOLING SYSTEM

GENERAL

This chapter illustrates and defines direct support maintenance for the engine cooling system.

CONTENTS

Page

6-1	VANEAXIAL COOLING FAN ASSEMBLY	6-2
6-2	GEAR BOX ASSEMBLY BREATHER AND SEAL	6-4
6-3	COOLING FAN DRIVE ASSEMBLY	6-6
6-4	COOLING FAN ASSEMBLIES AND MOUNT	6-24



6-1 VANEAXIAL COOLING FAN ASSEMBLY.

This task covers: a. Disassembly b. Assembly

INITIAL SETUP

Tools

General mechanic's tool kit
(SC 5180-90-N26)
Torque wrench (item 57, Appx F)
Arbor press (item 5, Appx F)
Machinist's vise (item 53, Appx F)
Adapter (item 4, Appx F)
Vise jaw caps (item 11, Appx F)
Socket wrench (item 45, Appx F)
Attachment socket wrench (item 6, Appx F)

Equipment Conditions

Fan assembly removed
(para 6-4)

Personnel Required

Two

References

TM 9-2350-314-10

Materials/Parts

Key washer (item 46, Appx E)

a. Disassembly.

CAUTION

Use vise jaw caps with vise to prevent damage to input shaft splines.

- 1 Place input shaft (1) in vise, and bend key washer (2) lock tab away from nut (3) on output shaft (4).
- 2 Remove nut (3), key washer (2), and impeller (5) from output shaft (4). Discard key washer.
- 3 Remove input shaft (1) from vise.

NOTE

If necessary, use arbor press to separate gear box from fan housing.

- 4 Remove ten screws (6) and gear box assembly (7) from fan housing (8).

NOTE

Marker is to be replaced only if damaged or illegible.

- 5 Remove marker (9), if damaged or illegible.

6-1 VANEAXIAL COOLING FAN ASSEMBLY - CONTINUED

b. Assembly.

- 1 Install new marker (9), if removed.
- 2 Install gear box assembly (7) in fan housing (8) with ten screws (6).

CAUTION

Use vise jaw caps with vise to prevent damage to input shaft splines.

- 3 Place input shaft (1) in vise.
- 4 Install impeller (5) on output shaft (4) with new key washer (2) and nut (3).
- 5 Torque nut (3) to 65–75 lb-ft (88–102 N·m) and bend lock tab on key washer (2) against nut (3).
- 6 Remove input shaft (1) from vise.
- 7 Fill gear box assembly (7) with lubricating oil in accordance with TM 9-2350-314-10.

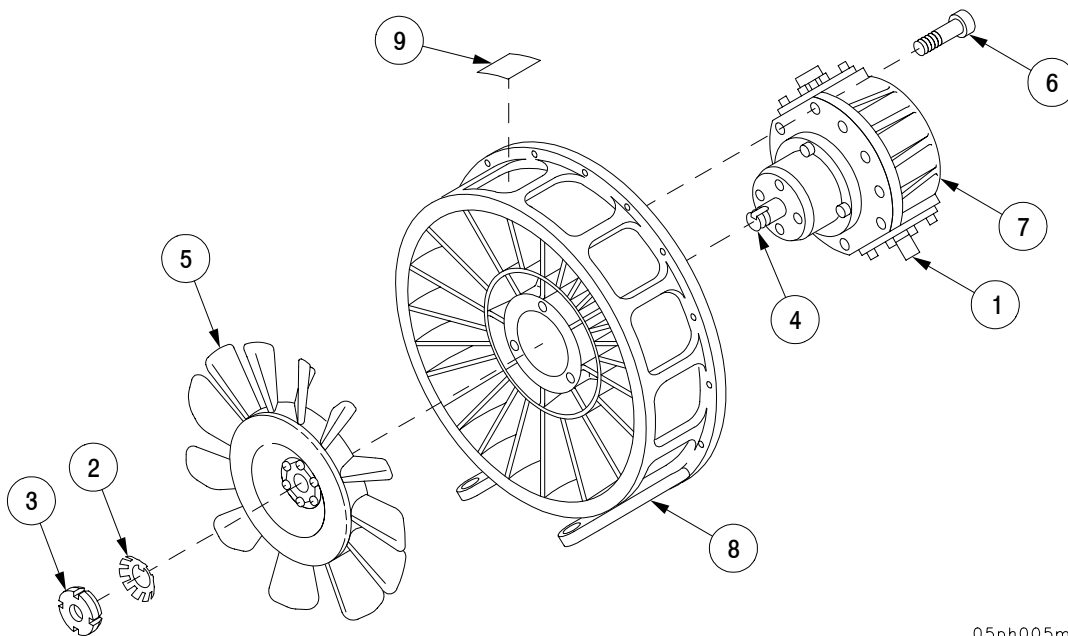

05ph005m

NOTE

FOLLOW-ON MAINTENANCE:
Install fan assembly (para 6-4)

6-2 GEAR BOX ASSEMBLY BREATHER AND SEAL.

This task covers: a. Disassembly b. Assembly

INITIAL SETUP

Tools

General mechanic's tool kit
(SC 5180-90-N26)
Utility pail (item 32, Appx F)
Torque wrench (item 57, Appx F)
Adapter (item 4, Appx F)
Attachment, socket wrench, 5/16 (item 6, Appx F)

Equipment Conditions

Gear box assembly removed
(para 6-1)

References

TM 9-2350-314-10

Materials/Parts

Seal (item 8, Appx E)
Preformed packing (item 54, Appx E)

a. Disassembly.

- 1 Remove plug (1) and drain lubricating oil from gear box assembly (2).
- 2 Remove breather (3) from gear box assembly (2).

CAUTION

When removing retainer from gear box assembly, retain shims for reinstalling. If shims are damaged, gear box assembly has to be replaced.

- 3 Remove four screws (4) and gasket (5), retainer (6) and shims (7, 8, 9) from gear box assembly (2).
- 4 Remove seal (10) from retainer (6). Discard seal.
- 5 Remove preformed packing (11) from retainer (6). Discard preformed packing.

NOTE

Decal is to be replaced only if damaged or illegible.

- 6 Remove decal (12) if damaged or illegible.
- 7 Ensure all interfacing surfaces of plug (1), gearbox assembly (2), four screws (4), retainer (6), and shims (7, 8, 9) are free of paint and primer prior to assembly.

6-2 GEAR BOX ASSEMBLY BREATHER AND SEAL - CONTINUED

b. Assembly.

- 1 Install new decal (12), if removed.
- 2 Install new preformed packing (11) on retainer (6).
- 3 Install new seal (10) in retainer (6).

NOTE

Install shims as required to achieve .004 - .008 gear backlash.

- 4 Install retainer (6) with shims (7, 8, 9) and gasket (5) with four screws (4). Torque screws to 12-15 lb-ft (16-20 N-m).
- 5 Install breather (3) in gear box assembly (2).
- 6 Fill gear box assembly (2) with lubricating oil in accordance with TM 9-2350-314-20-1-1 (PMCS).
- 7 Install plug (1) in gear box assembly (2).

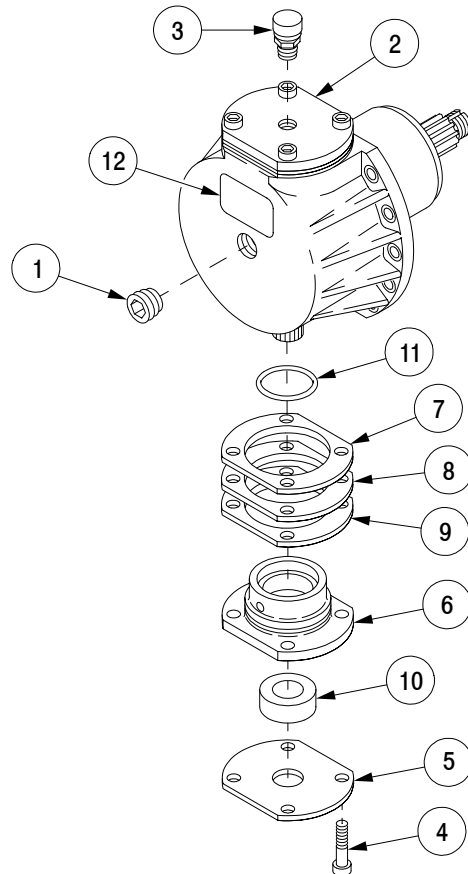

05ph006m

NOTE

FOLLOW-ON MAINTENANCE:
Gear box assembly installed (para 6-1)

6-3 COOLING FAN DRIVE ASSEMBLY.

- This task covers:
- | | |
|-----------------|----------------|
| a. Removal | b. Disassembly |
| c. Inspection | d. Assembly |
| e. Installation | |
-

INITIAL SETUP

Tools

General mechanic's tool kit
(SC 5180-90-N26)
Torque wrench (item 57, Appx F)
Arbor press (item 5, Appx F)
Outside micrometer caliper set (item 9, Appx F)
Indicating dial (item 13, Appx F)
Fabricated fan drive bracket (item 7, Appx F)
Snapping pliers (item 33, Appx F)
Depth micrometer (item 30, Appx F)
Pliers, wire twisting (item 34, Appx F)

Equipment Conditions

Fan drive shafts removed
(TM 9-2350-314-20-1-1)

References

TM 9-214
TM 9-2350-314-20-1-1

Materials/Parts

Kit, repair, drive assembly, fan
(item 25, Appx E)
Dry-cleaning solvent (item 29, Appx B)

a. Removal.

- 1 Remove 12 screws (1) and 12 lockwashers (2). Discard lockwashers.
- 2 Remove cooling fan drive assembly (3) and gasket (4) from transfer assembly (5). Discard gasket.

6-3 COOLING FAN DRIVE ASSEMBLY - CONTINUED

a. Removal - Continued

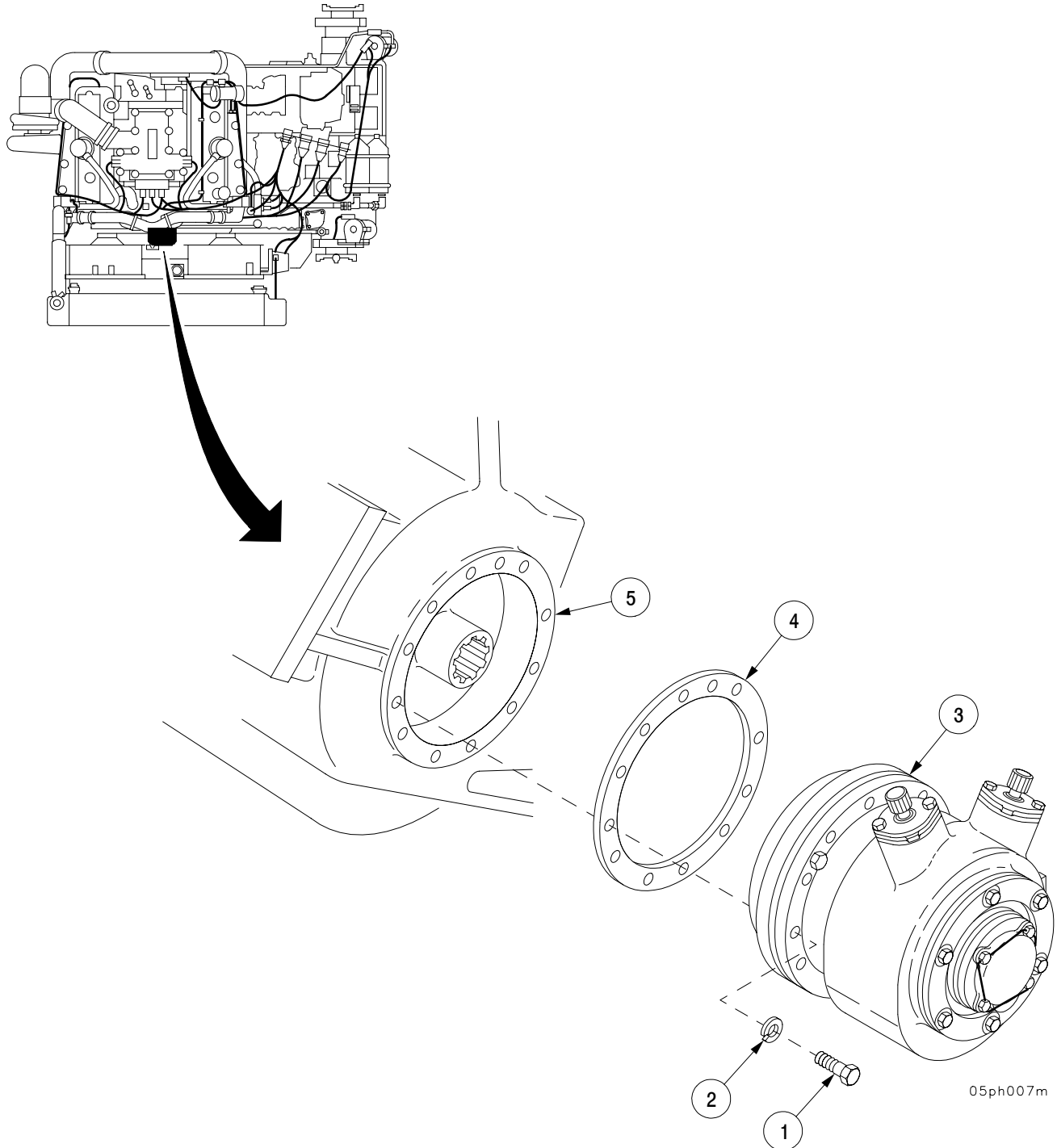

6-3 COOLING FAN DRIVE ASSEMBLY - CONTINUED

b. Disassembly.

- 1 Remove two screws (6), gasket (7), and inner housing cover (8) from cooling fan drive assembly (3). Discard gasket.
- 2 Remove preformed packing (9) from inner housing cover (8). Discard preformed packing.
- 3 Remove four screws (10), two bevel gear assemblies (11), two shims (12), and two preformed packings (13). Discard preformed packings.

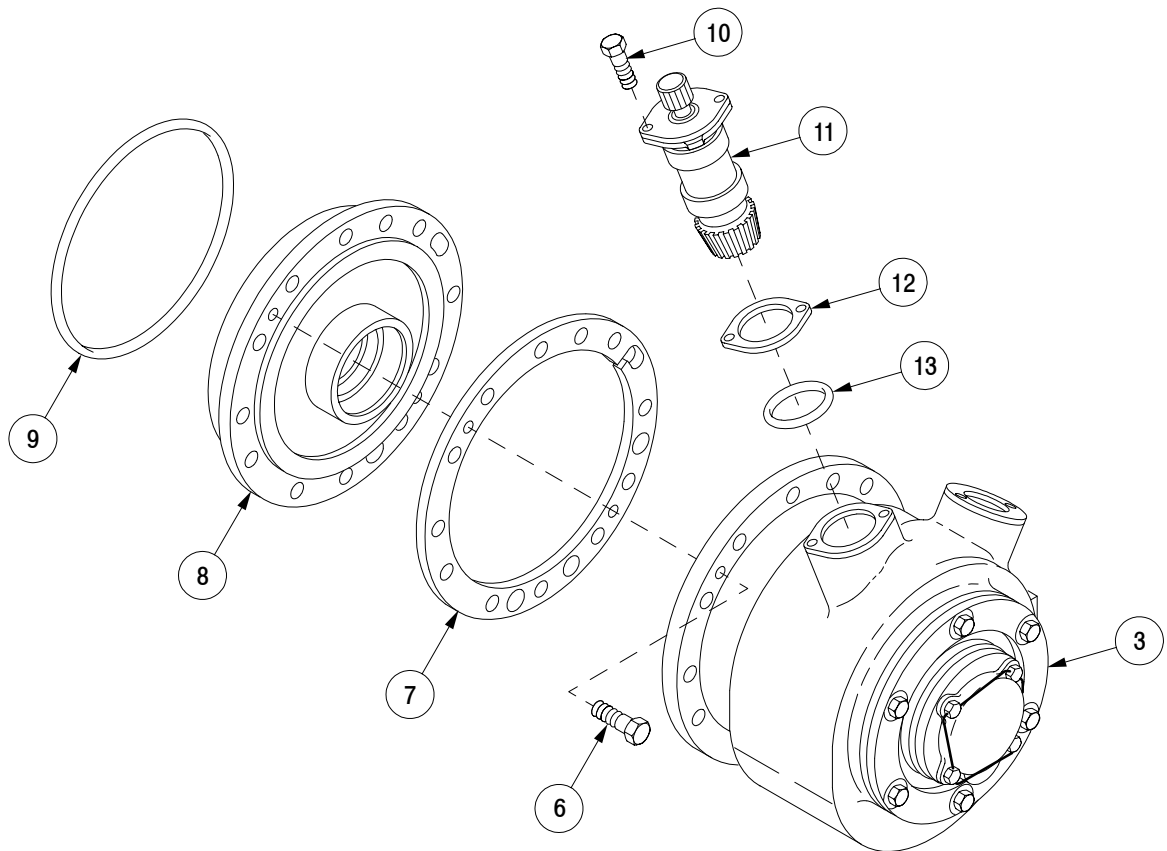

05ph008m

6-3 COOLING FAN DRIVE ASSEMBLY - CONTINUED

b. Disassembly - Continued**NOTE**

- There are two bevel gear case assemblies. Both assemblies are disassembled in the same manner. This task disassembles only one bevel gear case assembly.
- Perform steps 4 through 8 for disassembly of bevel gear case assembly.

- 4 Remove retainer (14) from bevel gear case assembly (11).
- 5 Remove preformed packing (15) and seal (16). Discard preformed packing and seal.
- 6 Straighten locking tabs on key washer (17).
- 7 Remove nut (18) and key washer (17). Discard key washer.
- 8 Remove bearing (19), spacer (20), bearing (21), and sleeve (22) from gear shaft (23).

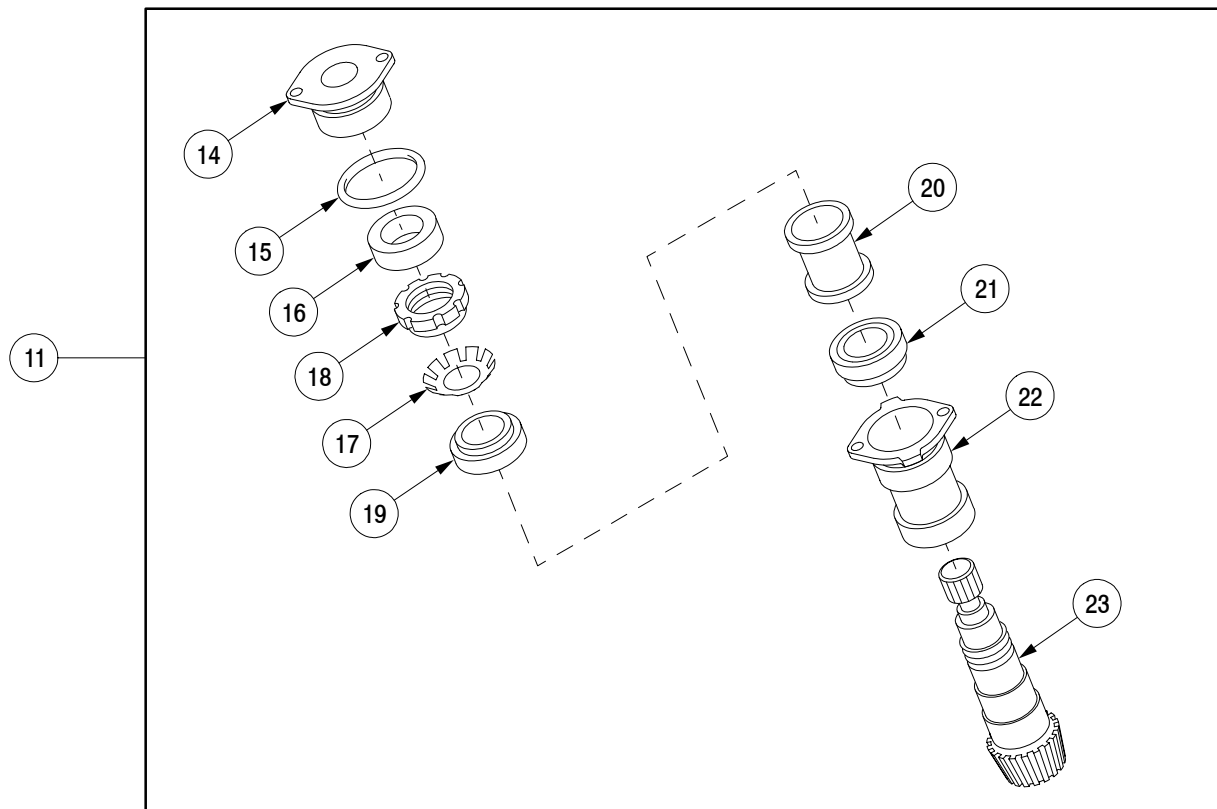

05ph009m

6-3 COOLING FAN DRIVE ASSEMBLY - CONTINUED

b. Disassembly - Continued

- 9 Remove lockwire (24), four screws (25), cover (26), and bearing gasket (27) from cooling fan drive assembly (3). Discard gasket and lockwire.

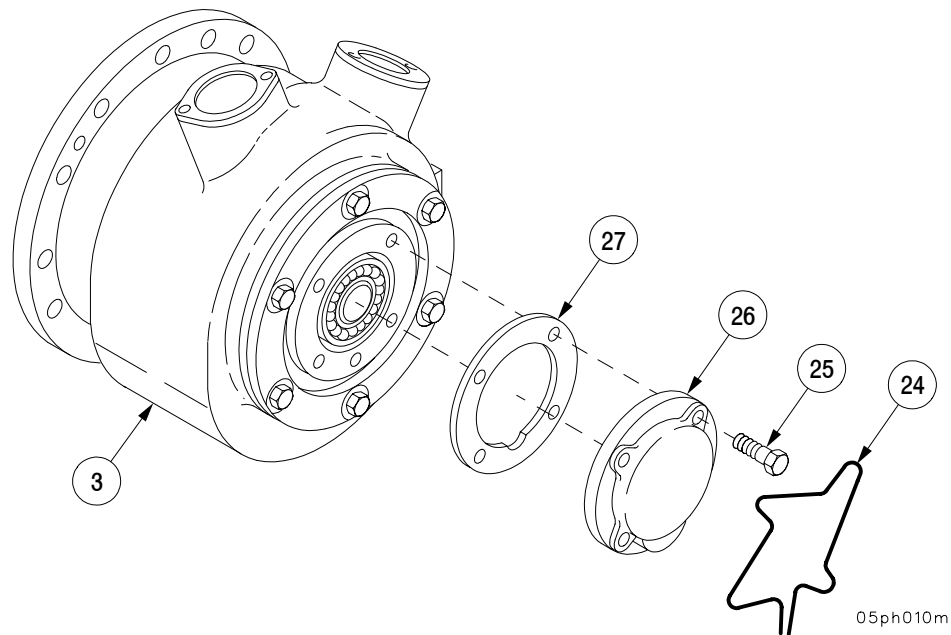

NOTE

Quantity of shims will vary. Measure thickness of shims and record information for use during assembly.

- 10 Remove six screws (28), housing (29), preformed packing (30), and shims (31). Discard shim(s) and preformed packing.

WARNING

Use care when removing snap and retaining rings. Snap and retaining rings are under spring tension and can act as projectiles when released and could cause severe eye injury.

- 11 Remove retaining ring (32) and bearing (33). Discard retaining ring.
- 12 Remove drive shaft assembly (34) from fan drive housing (35).
- 13 Remove bearing (36) from drive shaft assembly (34).
- 14 Remove lockwire (37), six screws (38), and gear (39) from drive shaft (40). Discard lockwire.

6-3 COOLING FAN DRIVE ASSEMBLY - CONTINUED

b. Disassembly - Continued

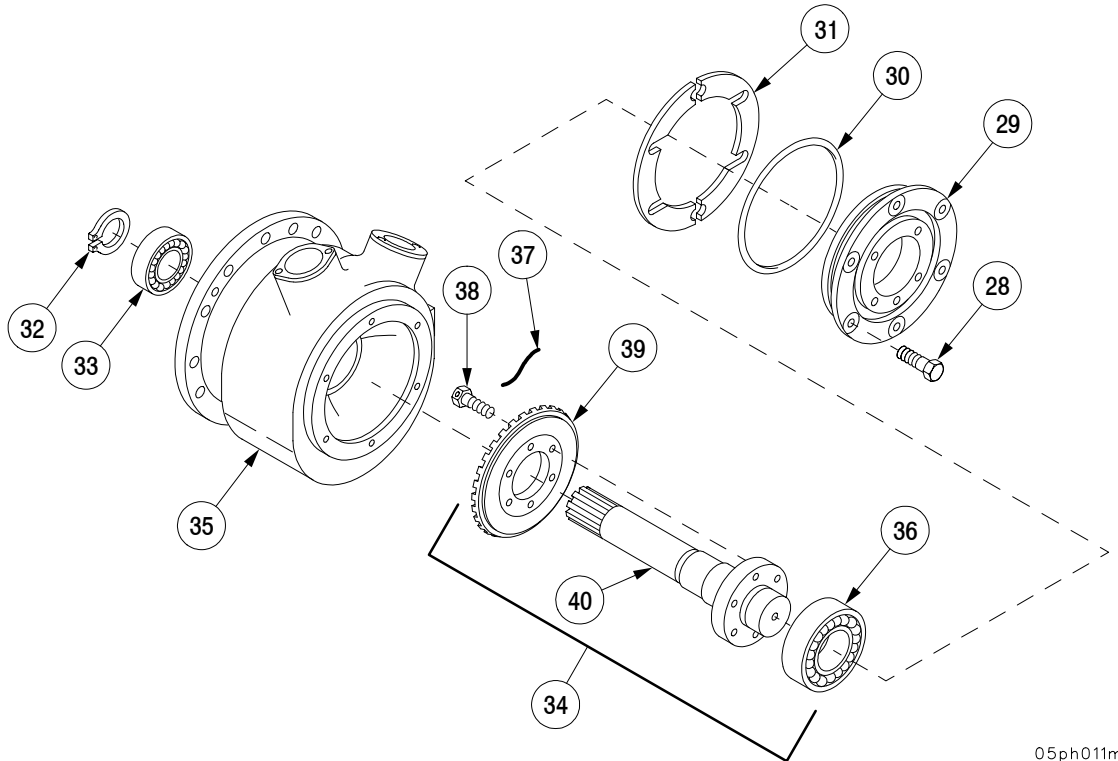

05ph011m

c. Inspection.

WARNING

Dry-cleaning solvent (P-D-680), used to clean parts, is toxic and flammable. Wear protective goggles and gloves and use only in a well-ventilated area. Avoid contact with skin, eyes, and clothes. Do not breathe vapors. Do not use near open flame or excessive heat. Do not smoke when using solvent. Failure to do so could cause **SERIOUS INJURY**. If you become dizzy while using dry-cleaning solvent, get fresh air immediately, and if necessary, get medical attention. If contact with skin or clothes is made, flush thoroughly with water. If the solvent contacts your eyes, wash them with water immediately and obtain medical aid (ref. FM 21-11).

- 1 Clean all parts before inspection with dry-cleaning solvent.

6-3 COOLING FAN DRIVE ASSEMBLY - CONTINUED

c. Inspection - Continued

- 2 Inspect inner housing cover (8) for cracks or distortion. Replace if cracked or distorted.

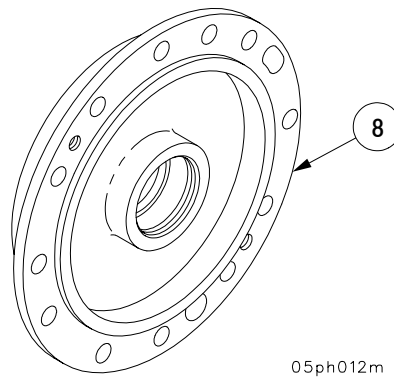

- 3 Inspect two retainers (14) for burrs, cracks or chips. Replace if burred, cracked or chipped.

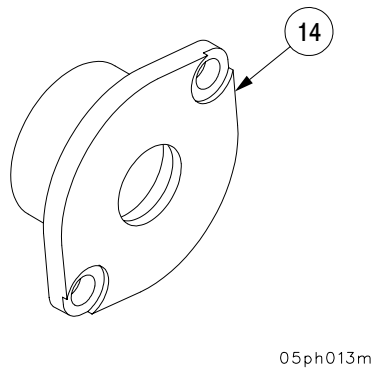

- 4 Inspect bearing (19) and bearing (21) for damage or defects (TM 9-214). Replace if defective.

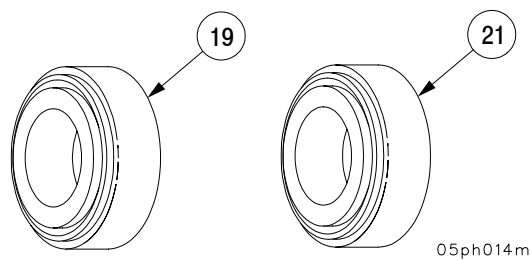

6-3 COOLING FAN DRIVE ASSEMBLY - CONTINUED

c. Inspection - Continued

- 5 Inspect sleeve (22) for cracks. Replace if cracked.

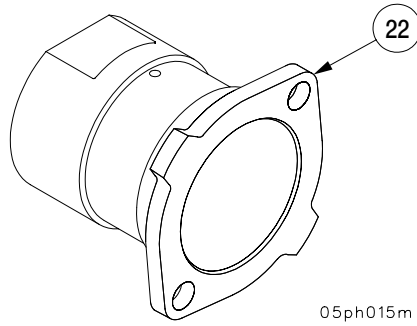

- 6 Inspect spacer (20) for burrs or sharp edges. Replace if burred or defective.

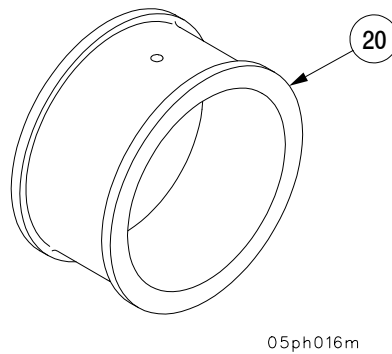

- 7 Inspect gearshaft (23) for burrs, chipped, or broken splines. Replace if burred or splines are chipped or broken.

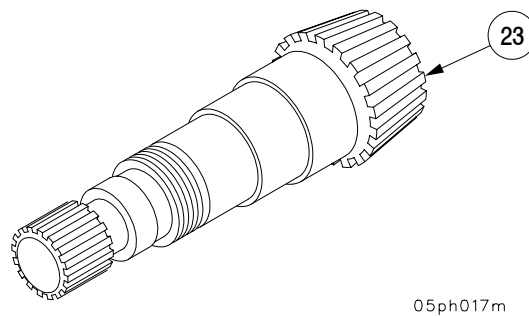

6-3 COOLING FAN DRIVE ASSEMBLY - CONTINUED

c. Inspection - Continued

- 8 Inspect cover (26) for burrs and cracks. Replace if cracked. Remove burrs with fine file or stone.
- 9 Inspect housing (29) for nicks or damage. Replace if nicked or damaged.

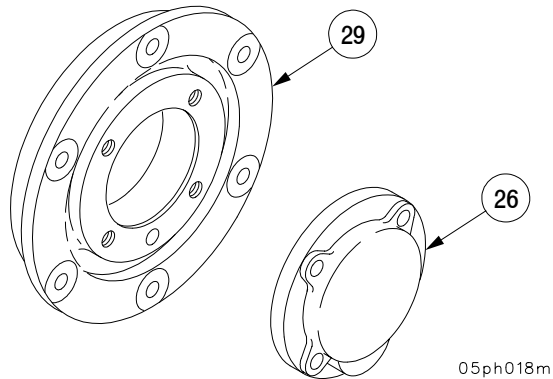

- 10 Inspect bearing (33) and bearing (36) for damage or defects (TM 9-214). Replace if defective.

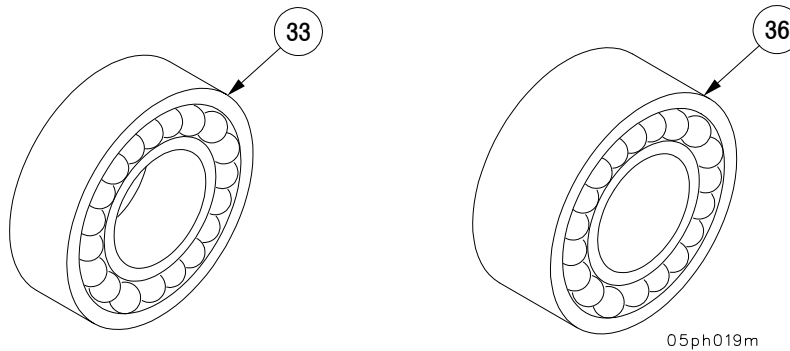

- 11 Inspect gear (39) for burrs, cracked, or broken splines. Replace if splines are cracked or broken. Remove burrs with fine file or stone.

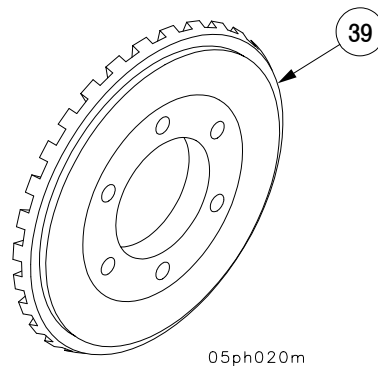

6-3 COOLING FAN DRIVE ASSEMBLY - CONTINUED

c. Inspection - Continued

- 12 Inspect drive shaft (40) for burrs, cracked, or broken splines. Replace if splines are cracked or broken. Remove burrs with fine file or stone.

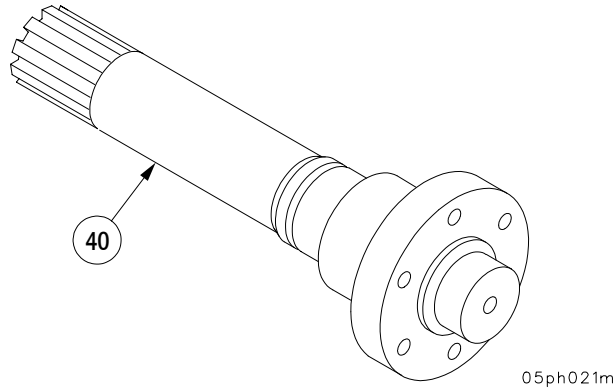

- 13 Inspect fan drive housing (35) for cracks or damage. Replace if cracked or damaged.

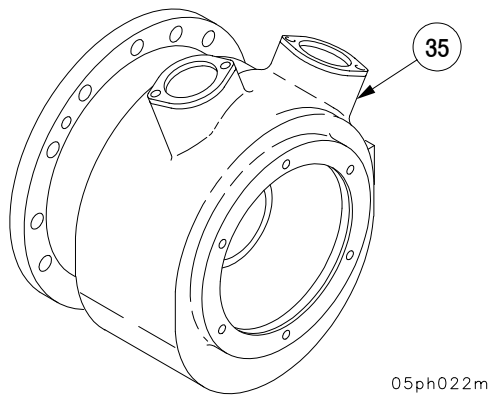

6-3 COOLING FAN DRIVE ASSEMBLY - CONTINUED

d. Assembly.

- 1 Install gear (39) on drive shaft (40) with six screws (38) and new lockwire (37). Torque screws to 32 lb-ft (43 N·m).
- 2 Install bearing (36) on drive shaft assembly (34).
- 3 Install drive shaft assembly (34) in fan drive housing (35).

NOTE

Install shims using thickness recorded during disassembly.

- 4 Install new shims (31), new preformed packing (30), and housing (29) on fan drive assembly (3) with six screws (28).

WARNING

Use care when installing snap and retaining rings. Snap and retaining rings are under spring tension and can act as projectiles when released and could cause severe eye injury.

- 5 Install bearing (33) and new retaining ring (32).

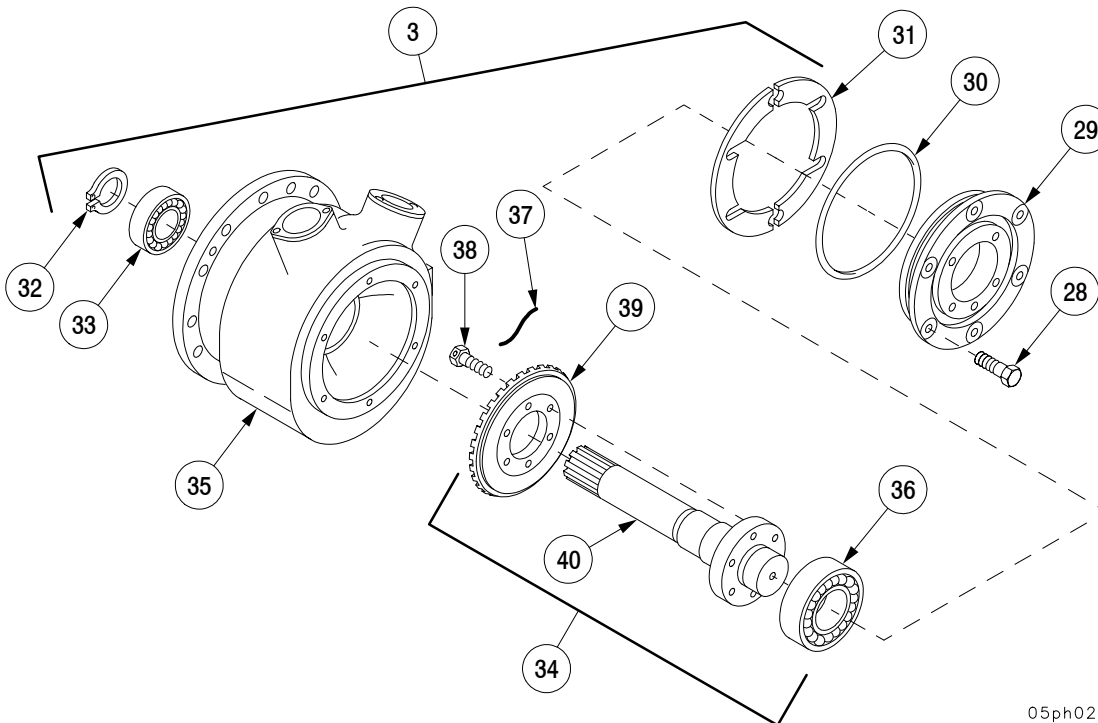

05ph023m

6-3 COOLING FAN DRIVE ASSEMBLY - CONTINUED

d. Assembly - Continued

- 6 Install new bearing gasket (27) and cover (26) on fan drive assembly (3) with four screws (25). Torque screws to 19-21 lb-ft (25-28 N·m).

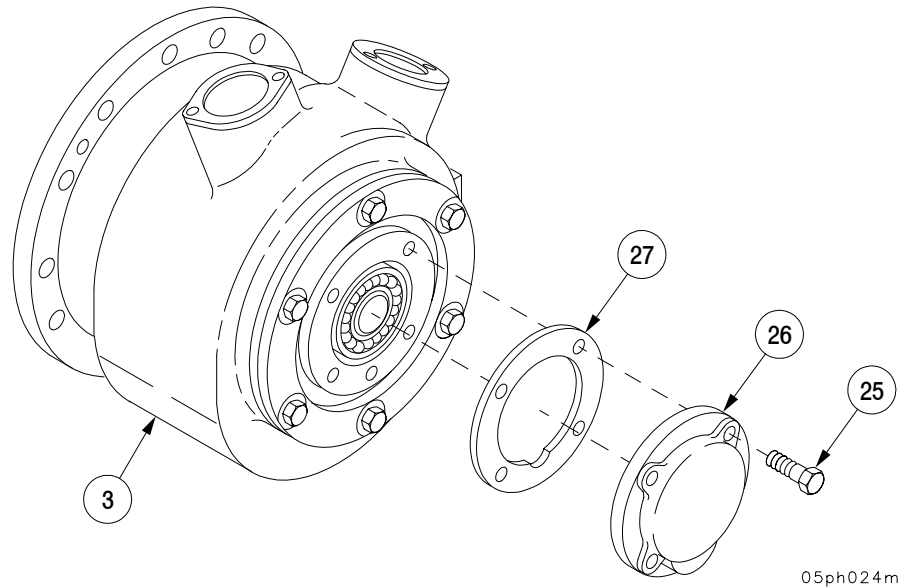

- 7 Measure distance between retainer boss and top of drive shaft (40) at a point between fan drive housing (35) and gear (39).
- 8 Add 0.671 in. (17.04 mm) to distance measured in Disassembly step 10 and record total as dimension B.

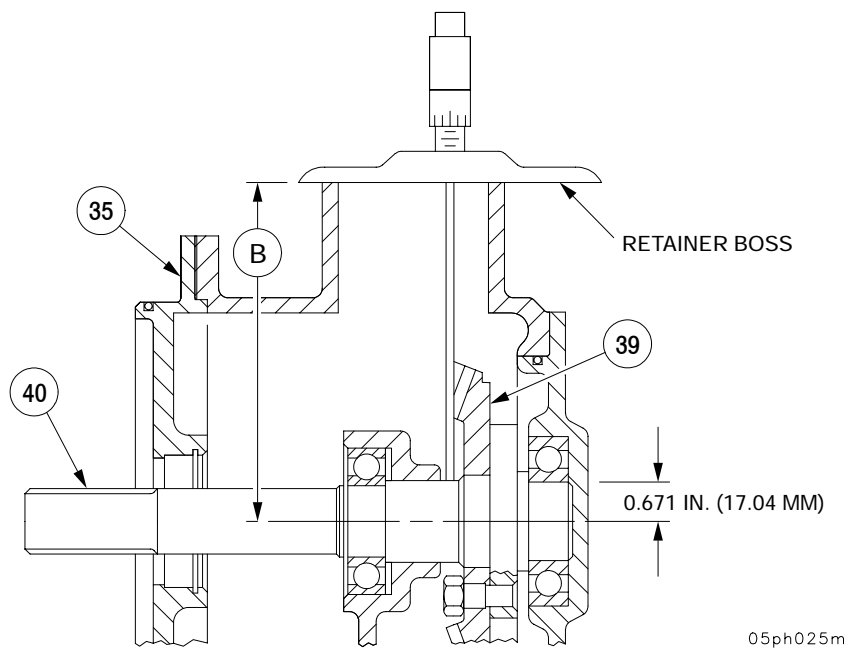

6-3 COOLING FAN DRIVE ASSEMBLY - CONTINUED

d. Assembly - Continued

NOTE

- There are two bevel gear case assemblies. Both assemblies are assembled in the same manner. This task assembles only one bevel gear case assembly.
- Perform steps 9 through 11 for assembly of bevel gear case assembly.
- Clean and lubricate new seal members in step 11 before assembly.

- 9 Install sleeve (22), bearing (21), spacer (20), and bearing (19) on gear shaft (23).
- 10 Install new key washer (17) and nut (18).
- 11 Install new seal (16), new preformed packing (15), and retainer (14) on bevel gear case assembly (11).

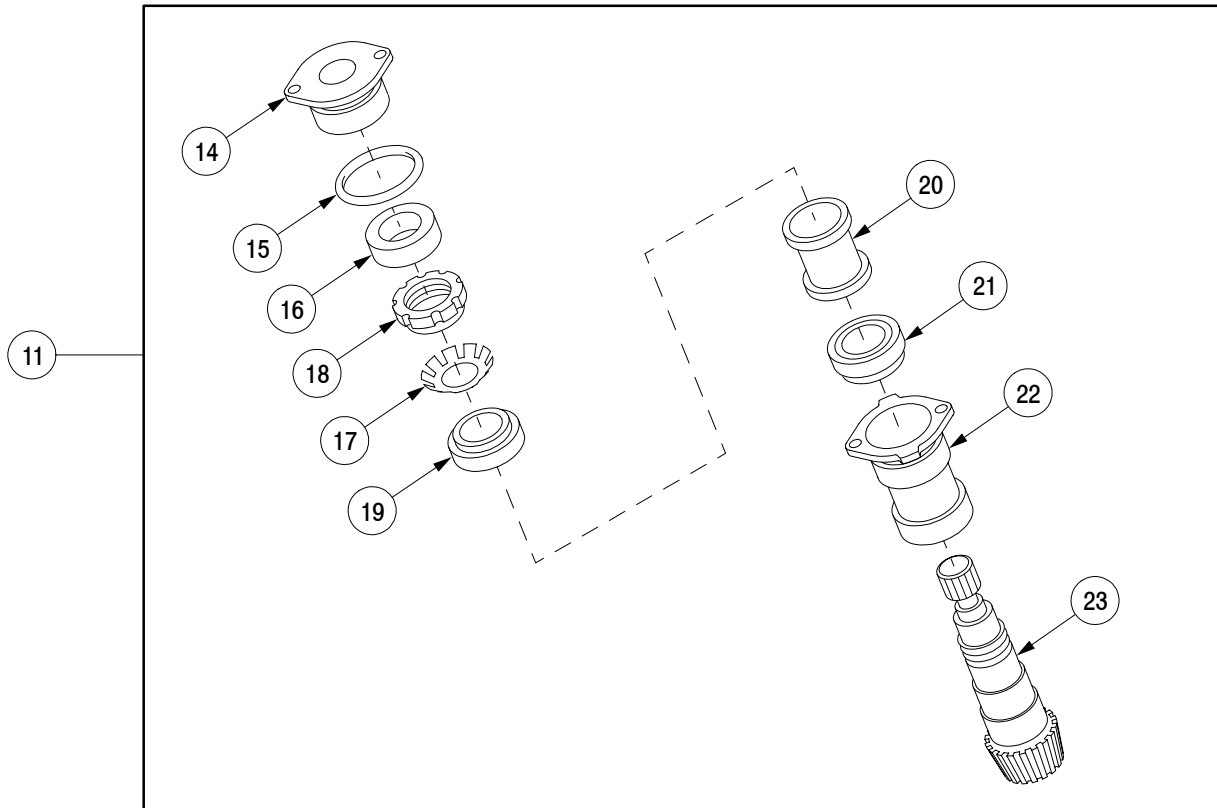

05ph009m

6-3 COOLING FAN DRIVE ASSEMBLY - CONTINUED

d. Assembly - Continued

- 12 Measure distance from end of gear shaft (23) to flange on retainer (14).
- 13 Record distance measured in step 12 as dimension A.
- 14 Subtract dimension A from dimension B (step 8) and record result as dimension C.

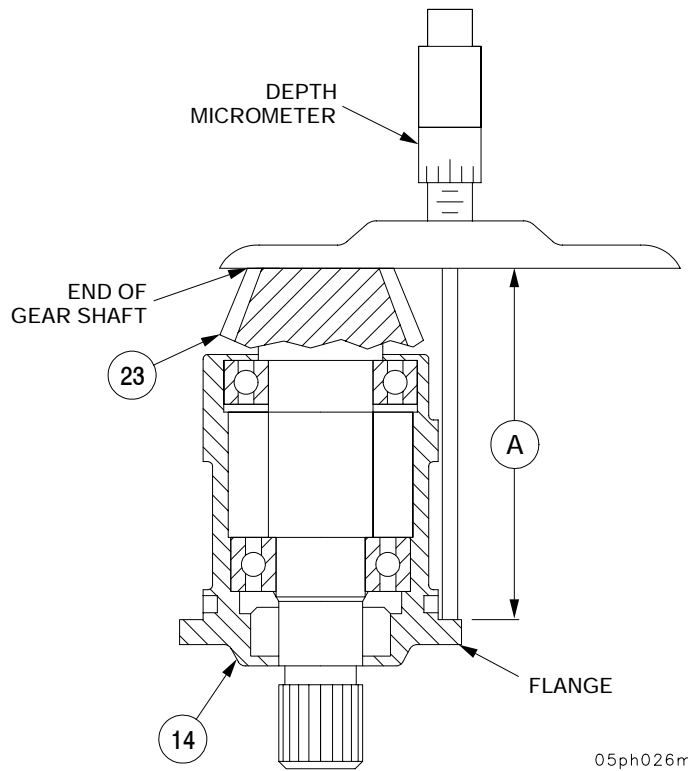

- 15 Read dimension Z from face of gear shaft (23).
- 16 Subtract dimension C (step 14) from dimension Z and record result as the shim (12) thickness required.

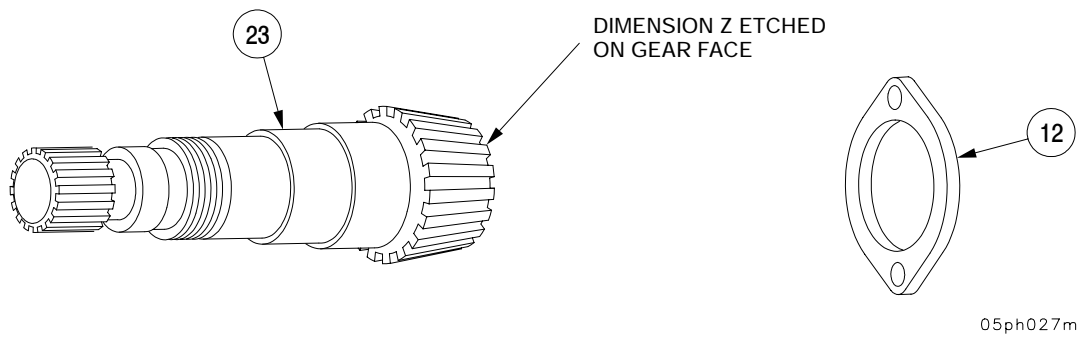

6-3 COOLING FAN DRIVE ASSEMBLY - CONTINUED

d. Assembly - Continued

NOTE

Use shim thickness as determined in step 16.

- 17 Install two new preformed packings (13), shims (12), and two bevel gear case assemblies (11) into fan drive assembly (3) with four screws (10). Torque screws to 19-21 lb-ft (25-28 N-m).

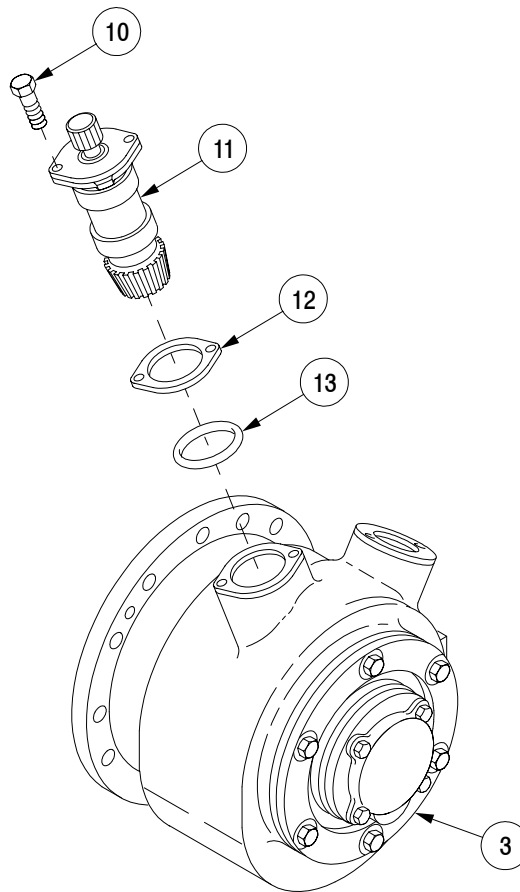

05ph028m

6-3 COOLING FAN DRIVE ASSEMBLY - CONTINUED

d. Assembly - Continued

NOTE

- Backlash between gear shaft and draft shaft must be between 0.002 and 0.004 in. (0.0508 and 0.1016 mm).
- Perform steps 18-23 to check backlash.

- 18 Set cooling fan drive assembly (3) on support blocks on a flat surface.
- 19 Install fabricated fan drive bracket (41) in line with bevel gear case assembly (11) on cooling fan drive assembly (3) with two screws (42) and nuts (43).
- 20 Install dial indicator (44) on fabricated fan drive bracket (41) with plunger positioned on bevel gear teeth.
- 21 Hold drive shaft (40) secure to prevent any movement and rotate gear shaft (11) counterclockwise as far as possible (do not force).
- 22 Zero dial indicator and slowly rotate gear shaft (11) clockwise as far as possible (do not force). Read backlash measurement.

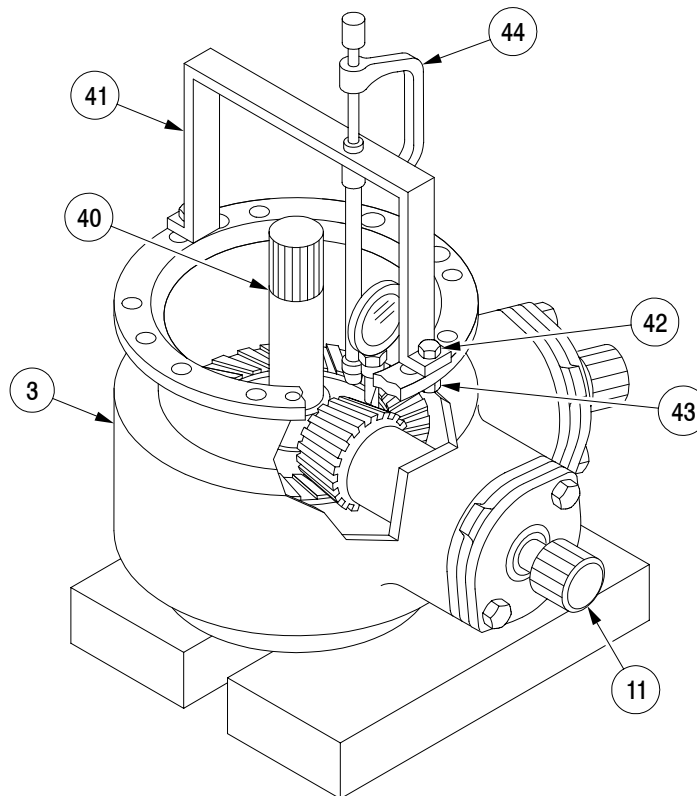

05ph029m

6-3 COOLING FAN DRIVE ASSEMBLY - CONTINUED

d. Assembly - Continued

23 Add or remove shim(s) (31) between fan drive housing (35) and housing (29) to obtain required backlash.

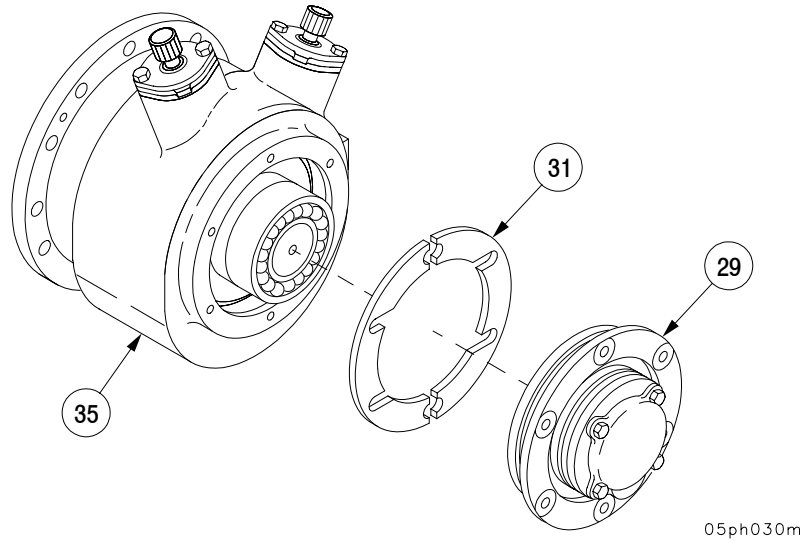

24 Install new lockwire (24) on four screws (25).

25 Install new gasket (7) and inner housing cover (8) on cooling fan drive assembly (3) with two screws (6).

26 Install new preformed packing (9) on inner housing cover (8).

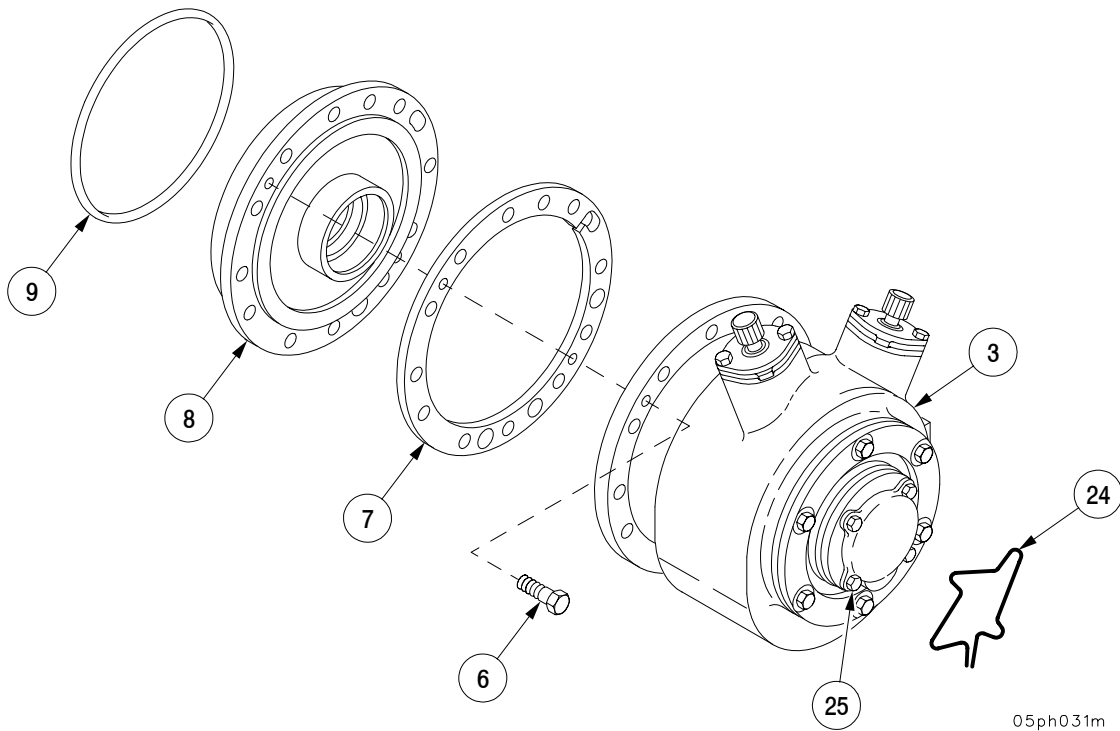

6-3 COOLING FAN DRIVE ASSEMBLY - CONTINUED

e. Installation.

- 1 Install new gasket (4).

NOTE

Rubber hammer may be needed to seat cooling fan drive assembly during installation.

- 2 Install cooling fan drive assembly (3) on transfer assembly (5) with 12 screws (1) and 12 new lockwashers (2).

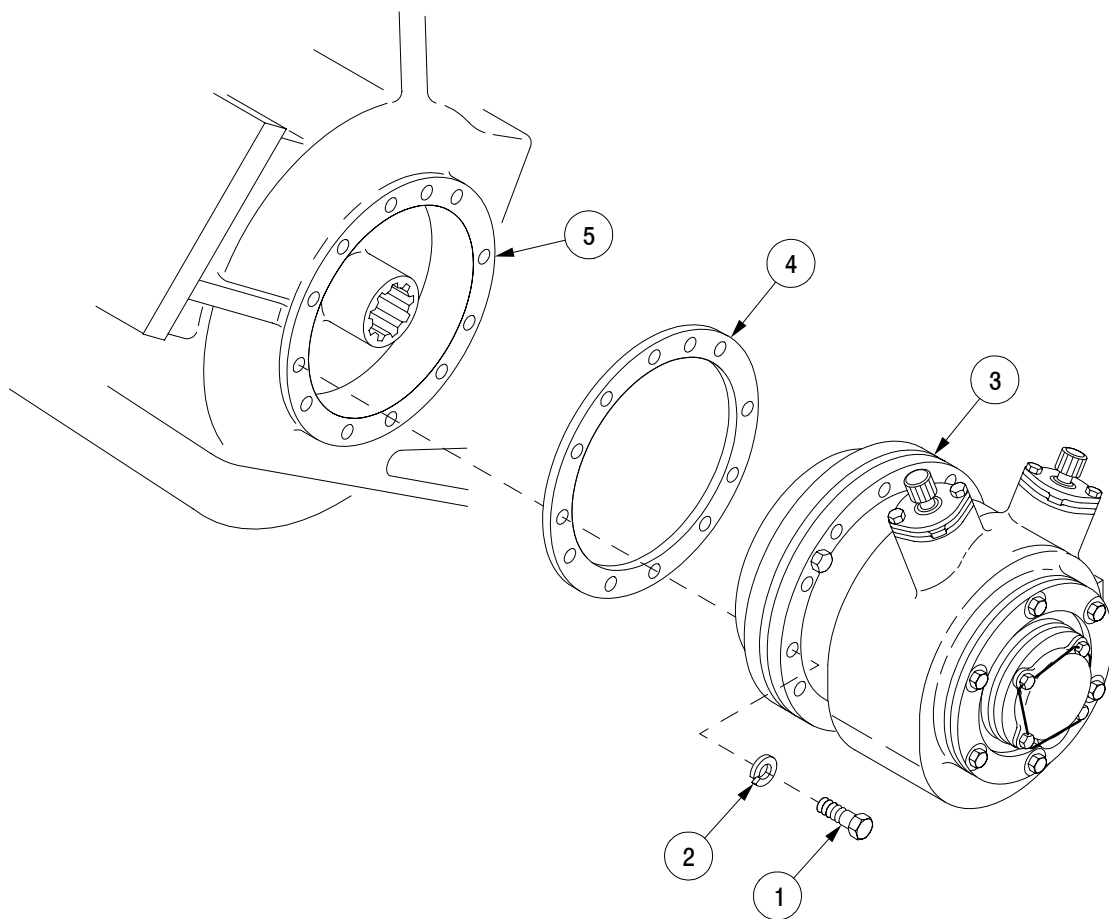

05ph032m

NOTE**FOLLOW-ON MAINTENANCE:**

Install fan drive shafts (TM 9-2350-314-20-1-1)
Check engine drive fans backlash
(TM 9-2350-314-20-1-1)

6-4 ENGINE COOLING FAN ASSEMBLIES AND MOUNT.

This task covers: a. Removal b. Installation

INITIAL SETUP

Tools

General mechanic's tool kit
(SC 5180-90-N26)

Materials/Parts

Lockwashers (16) (item 78, Appx E)

Equipment Conditions

Powerpack removed (TM 9-2350-314-20-1-1)
Radiator removed (TM 9-2350-314-20-1-1)
Fan drive shafts removed (TM 9-2350-314-20-1-1)
Radiator fan shroud removed (TM 9-2350-314-20-1-1)

Personnel Required

Two

References

TM 9-2350-314-10
TM 9-2350-314-20-1-1

a. Removal.

NOTE

Length of screws will vary. Note length and location of screws to aid in installation.

- 1 Remove four screws (1), four flat washers (2), four lockwashers (3), and fan assembly (4) from mount (5). Discard lockwashers.
- 2 Remove eight screws (6), eight flat washers (7), eight lockwashers (8), and mount (5). Discard lockwashers.
- 3 Remove four screws (9), four flat washers (10), four lockwashers (11), and fan assembly (12). Discard lockwashers.

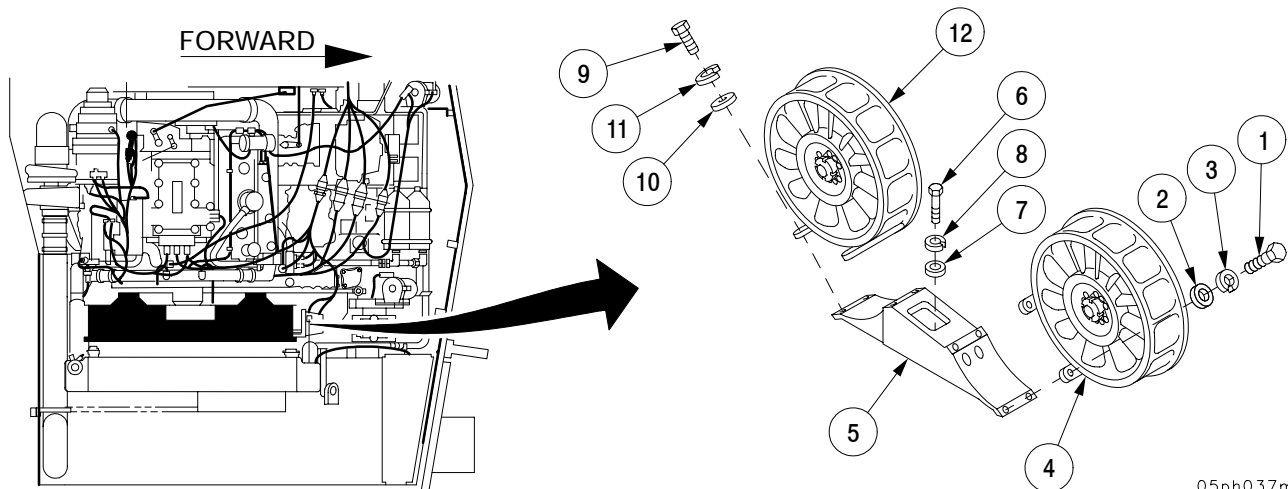

05ph037m

6-4 ENGINE COOLING FAN ASSEMBLIES AND MOUNT - CONTINUED

a. Installation.

- 1 Install fan assembly (12), four screws (9), four new lockwashers (11), and four flat washers (10).
- 2 Install mount (5) with eight screws (6), eight new lockwashers (8), and eight flat washers (10).
- 3 Install fan assembly (4) on mount (5) with four screws (1), four new lockwashers (3), and four flat washers (2).
- 4 Fill cooling fan assemblies (4 and 12) with lubricating oil in accordance with TM 9-2350-314-10.

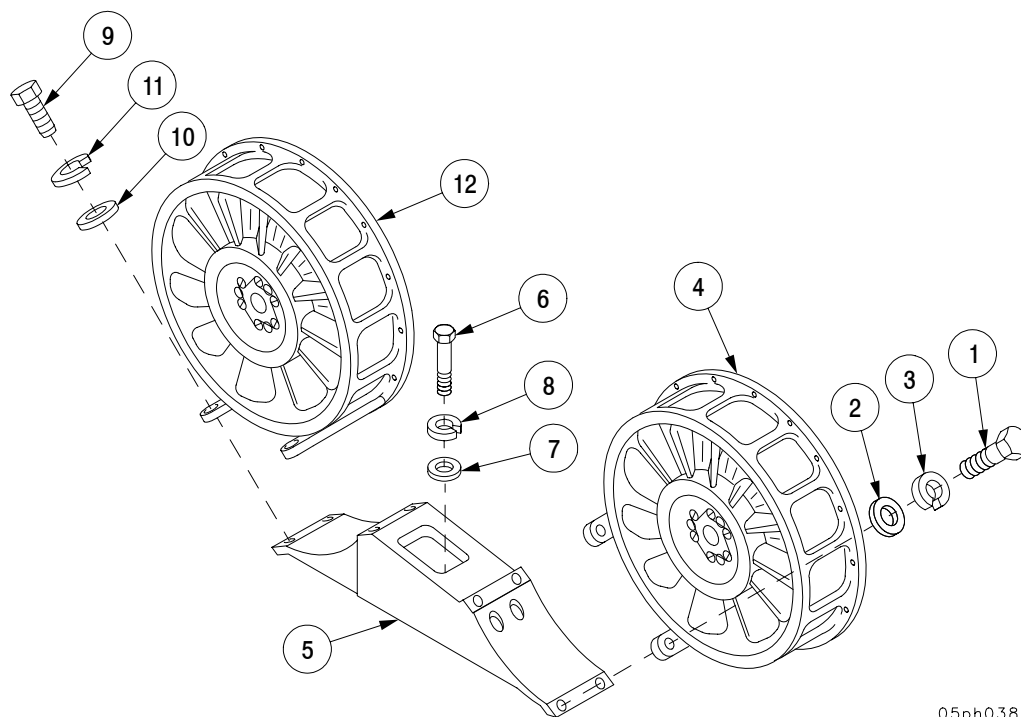

05ph038m

NOTE**FOLLOW-ON MAINTENANCE:**

- Install radiator fan shroud (TM 9-2350-314-20-1-1)
- Install fan drive shafts (TM 9-2350-314-20-1-1)
- Install radiator (TM 9-2350-314-20-1-1)
- Install powerpack (TM 9-2350-314-20-1-1)
- Check engine drive fans backlash (TM 9-2350-314-20-1-1)

CHAPTER 7 ELECTRICAL SYSTEMS

GENERAL

This chapter contains maintenance procedures for hull electrical systems and components authorized by the MAC for direct support.

Instructions for repair of individual wiring harnesses are contained in this chapter.

Each electrical cable is marked with a wire numbered metal tag attached to the junction of terminal of the cable. All electrical circuits shown in schematics and wiring diagrams are identified by wire numbers listed in each area.

<u>CONTENTS</u>	<u>Page</u>
Section I. GENERATOR	
7-1 GENERATOR PULLEY ASSEMBLY	7-2
Section II. INSTRUMENT OR ENGINE CONTROL PANELS	
7-2 GUN TUBE TRAVEL LOCK CONTROL BOX ASSEMBLY	7-6
7-3 VOLTAGE REGULATOR CONTROL BOX ASSEMBLY	7-13
7-4 ENCLOSURE ASSEMBLY — CREW COMPARTMENT WARNING LIGHT	7-20
7-5 ACCESSORY CONTROL BOX (P/N 12268582)	7-24
7-5A ACCESSORY CONTROL BOX (P/N 12268547)	7-40
Section III. HULL WIRING HARNESS	
7-6 WIRING HARNESS AND CABLE REPAIR	7-41
Section IV. VENTILATING EQUIPMENT	
7-7 PERSONNEL VENTILATING AIR DUCT FAN	7-56

Section I. GENERATOR

7-1 GENERATOR PULLEY ASSEMBLY.

This task covers: a. Disassembly b. Assembly

INITIAL SETUP

Tools

General mechanic's tool kit
(SC 5180-90-N26)
Arbor press (item 5, Appx F)
Bearing press fixture (item 19, Appx F)
Torque wrench (item 57, Appx F)
Snapping pliers (item 33, Appx F)
Socket wrench socket (item 48, Appx F)
Socket wrench adapter (item 2, Appx F)
Socket wrench adapter (item 3, Appx F)
Machinist vise (item 53, Appx F)
Vise jaw caps (item 11, Appx F)

Materials/Parts

Seals (2) (item 12, Appx E)
Sealing compound (item 27, Appx B)
Aircraft grease (item 12, Appx B)

Equipment Conditions

Generator pulley assembly removed
(TM 9-2350-314-20-1-2)

References

TM 9-2350-314-20-1-2

a. Disassembly.

- 1 Place pulley (1) in vise.
- 2 Remove nut (2) from pulley (1).
- 3 Press pulley (1) from bracket (3).

WARNING

Use care when removing snap and retaining rings. Snap and retaining rings are under spring tension and can act as projectiles when released and could cause severe eye injury.

- 4 Remove retaining ring (4), two seals (5), and double bearing (6) from bracket (3). Discard seals.
- 5 Remove alignment pin (7) from bracket (3).

b. Assembly.

- 1 Install alignment pin (7) in bracket (3).
- 2 Pack double bearing (6) with grease.

Section I. GENERATOR - CONTINUED

7-1 GENERATOR PULLEY ASSEMBLY - CONTINUED

b. Assembly - Continued

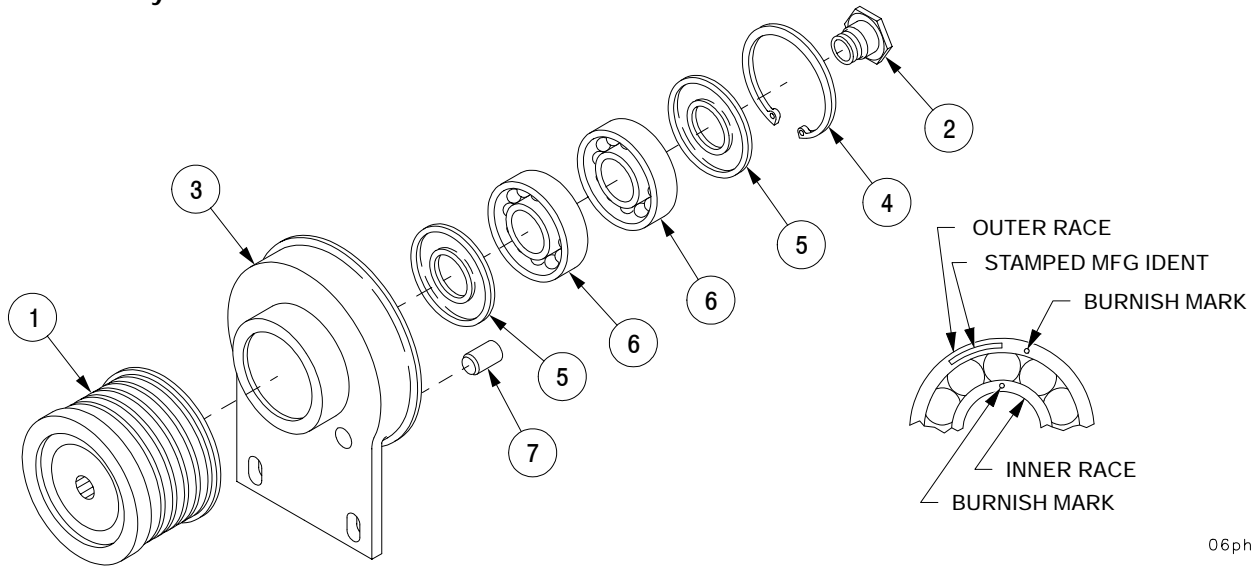

06ph037m

WARNING

Use care when installing snap and retaining rings. Snap and retaining rings are under spring tension and can act as projectiles when released and could cause severe eye injury.

CAUTION

Stamped faces of outer races shall face each other. A stamped face is one with stamped manufacturer's identification on it.

- 3 Burnish marks of outer races shall be aligned to $180^\circ \pm 15^\circ$ from each other. Burnish marks may be located on either side of bearings.

Section I. GENERATOR - CONTINUED

7-1 GENERATOR PULLEY ASSEMBLY - CONTINUED

b. Assembly - Continued

- 4 Burnish marks of inner races shall be aligned to $180^\circ \pm 15^\circ$ from each other. Burnish marks may be located on either side of bearings.



Failure to follow above information may cause bearing seizure.

- 5 Install double bearing (6), two new seals (5), and retaining ring (4) in bracket (3).
- 6 Install pulley (1) on bracket (3).



Adhesive sealant MIL-S-46163 can damage your eyes. Wear safety goggles/glasses when using: avoid contact with eyes. If sealant contacts eyes, flush eyes with water and get immediate medical attention.

- 7 Apply sealing compound to threads of nut (2).
- 8 Install nut (2) on pulley (1).
- 9 Place pulley (1) in vise.
- 10 Torque nut (2) as follows:
 - (a) Torque to 20-29 lb-ft (28-39 N·m).
 - (b) Back off nut (2).
 - (c) Torque to 15-17 lb-ft (20-23 N·m).

Section I. GENERATOR - CONTINUED

7-1 GENERATOR PULLEY ASSEMBLY - CONTINUED

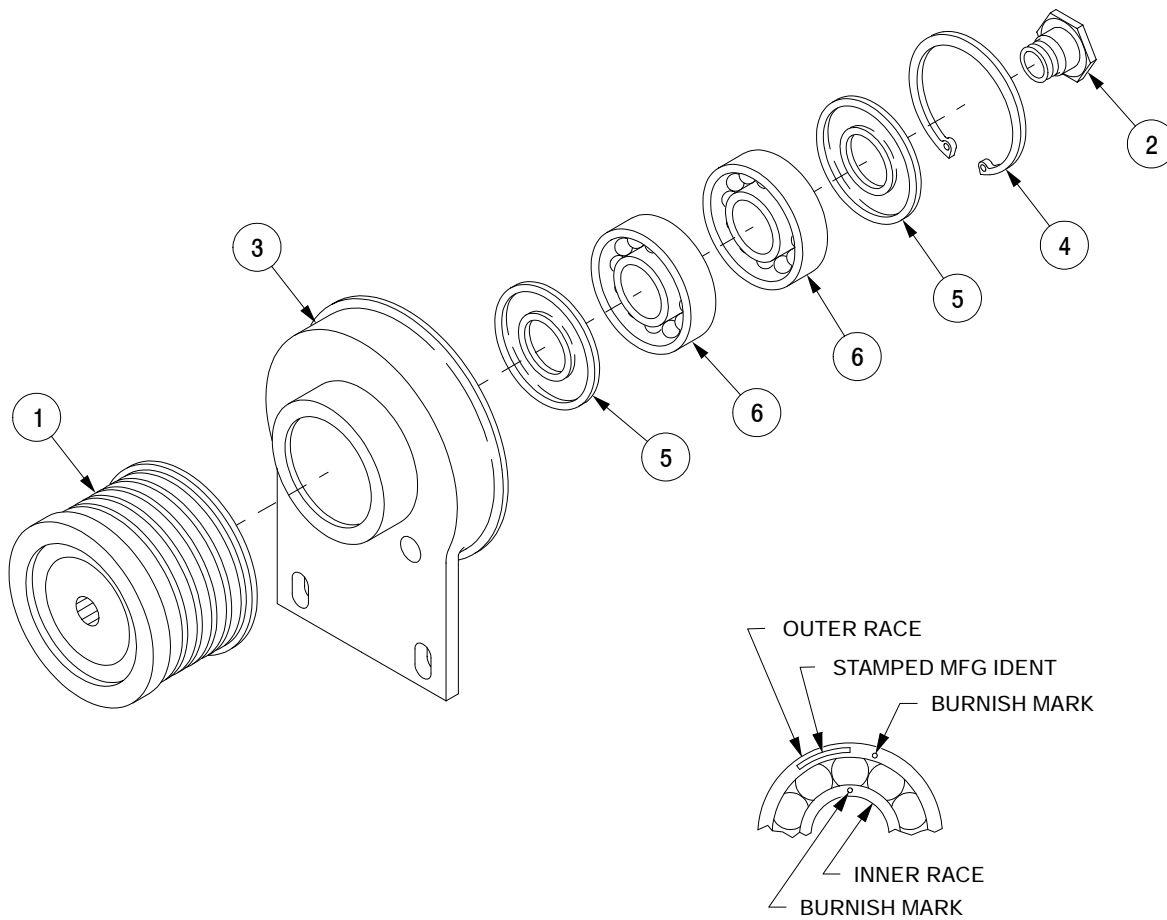

06ph038m

NOTE

FOLLOW-ON MAINTENANCE:
 Install generator pulley assembly
 (TM 9-2350-314-20-1-2)

Section II. INSTRUMENT OR ENGINE CONTROL PANELS

7-2 GUN TUBE TRAVEL LOCK CONTROL BOX ASSEMBLY.

This task covers: a. Disassembly b. Assembly

INITIAL SETUP

Tools

Fuel and electrical tool kit
(SC 5180-95-B08)
Soldering gun (item 49, Appx F)
Wire brush (item 8, Appx F)

Materials/Parts

Gasket (item 11, Appx E)
Lockwashers (2) (item 71, Appx E)
Solder (item 28, Appx B)
Flux, soldering (item 10, Appx B)
Dry-cleaning solvent (item 29, Appx B)
Seal(s) (item 86, Appx E)

Equipment Conditions

Gun tube travel lock control box assembly
removed (TM 9-2350-314-20-1-2)

References

TB SIG 222
TM 9-2350-314-20-1-2

NOTE

- To replace indicator light housing, perform Disassembly steps 1, 2, 3 and 5 thru 7 and Assembly steps 5, 6, 7 and 9 thru 11.
- To replace relay, perform Disassembly steps 3, 8, and 9 and Assembly steps 3, 4, and 9.
- To replace cable assembly, perform Disassembly steps 3 thru 6 and 8, 10, 11 and Assembly steps 1, 2, 4 and 6 thru 9.
- To replace POWER switch, perform Disassembly steps 3, 10, and 11 and Assembly steps 5, 6 and 13.
- To replace CONTROL switch, perform Disassembly steps 3, 12 and 13 and Assembly steps 3, 4, and 13.
- To replace face plate, perform Disassembly steps 3, 11, 13, and 14 and Assembly steps 1, 2, 3, 5, and 13.

Section II. INSTRUMENT OR ENGINE CONTROL PANELS - CONTINUED

7-2 GUN TUBE TRAVEL LOCK CONTROL BOX ASSEMBLY - CONTINUED

a. Disassembly.**NOTE**

There are three lenses, three LEDs, and three indicator light housings. All lenses, LEDs, and housings are removed in the same manner. Only one lens, LED, and housing are shown removed.

- 1 Remove three lenses (1) from three indicator light housings (2).
- 2 Remove three LEDs (3) from three lenses (1).

NOTE

An o-ring is installed on lens (1) as part of the lens. If this o-ring is damaged or missing the lens must be replaced.

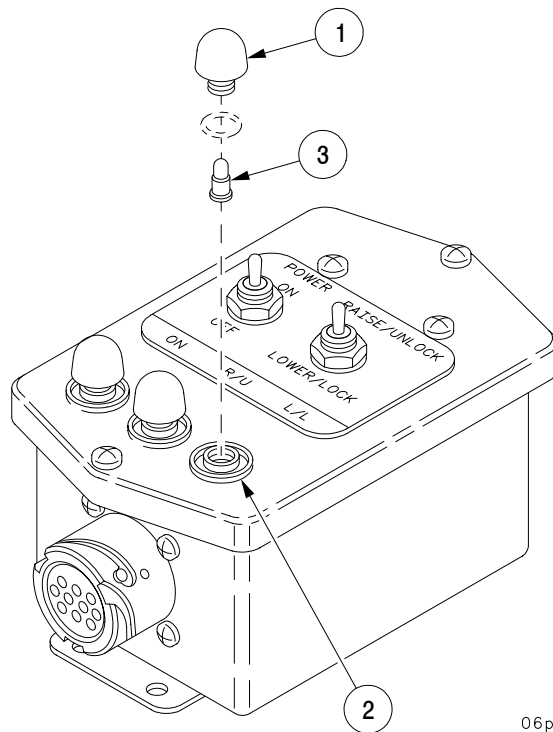

06ph039m

Section II. INSTRUMENT OR ENGINE CONTROL PANELS - CONTINUED

7-2 GUN TUBE TRAVEL LOCK CONTROL BOX ASSEMBLY - CONTINUED

a. Disassembly - Continued

- 3 Remove two screws (4) and separate gun tube travel lock control box cover (5) from gun tube travel lock control box housing (6).

NOTE

- Refer to electrical schematic foldouts for internal gun tube travel lock control box wiring.
 - Prior to removing wires, tag all electrical connections to ensure proper installation.
 - Before proceeding, see detailed instructions on soldering and solder (TB SIG 222).
- 4 Remove four screws (7), flange (8), cable assembly (9) and gasket (10) from gun tube travel lock control box housing (6). Discard gasket.
 - 5 Unsolder and remove wire (11) from each terminal (12) on three indicator light housings (2).
 - 6 Unsolder and remove two wires (13) from each terminal (14) on three indicator light housings (2).
 - 7 Remove three nuts (15), three lockwashers (16) and three indicator light housings (2) from gun tube travel lock control box cover (5).
 - 8 Unsolder and remove wires (17) from relay terminals (18).
 - 9 Remove two screws (19), two nuts (20), two lockwashers (21) and relay (22) from gun tube travel lock control box cover (5). Discard lockwashers.
 - 10 Remove two screws (23), two lockwashers (24), two flat washers (25) and two wires (26) from two terminals (27) of POWER switch (28).
 - 11 Remove nut (29), lockwasher (30), seal (31) and POWER switch (28) from gun tube travel lock control box cover (5). Discard seal.
 - 12 Remove six screws (32), six lockwashers (33), six flat washers (34) and six wires (35) from six terminals (36) of CONTROL switch (37).
 - 13 Remove nut (38), lockwasher (39), seal (40), and switch (37) from gun tube travel lock control box cover (5). Discard seal.

NOTE

Replace faceplate only if damaged or illegible.

- 14 Remove faceplate (41) from gun tube travel lock control box cover (5).

Section II. INSTRUMENT OR ENGINE CONTROL PANELS - CONTINUED

7-2 GUN TUBE TRAVEL LOCK CONTROL BOX ASSEMBLY - CONTINUED

a. Disassembly - Continued

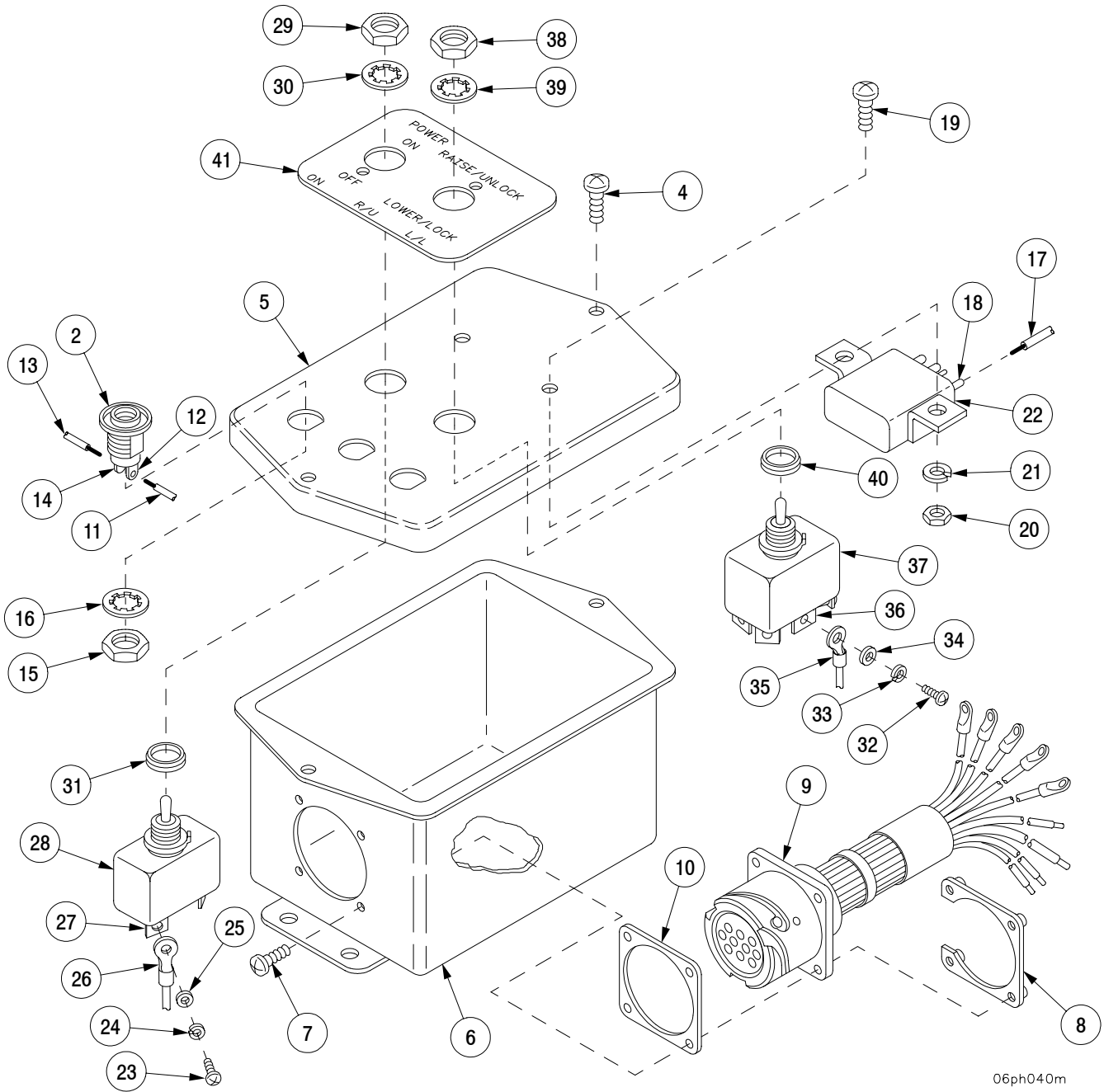

06ph040m

Section II. INSTRUMENT OR ENGINE CONTROL PANELS - CONTINUED

7-2 GUN TUBE TRAVEL LOCK CONTROL BOX ASSEMBLY - CONTINUED

b. Assembly.

NOTE

Before proceeding, see detailed instructions on soldering and solder (TB SIG 222).

WARNING

Dry-cleaning solvent (P-D-680), used to clean parts, is toxic and flammable. Wear protective goggles and gloves and use only in a well-ventilated area. Avoid contact with skin, eyes, and clothes. Do not breathe vapors. Do not use near open flame or excessive heat. Do not smoke when using solvent. Failure to do so could casue **SERIOUS INJURY**. If you become dizzy while using dry-cleaning solvent, get fresh air immediately, and if necessary, get medical attention. If contact with skin or clothes is made, flush thoroughly with water. If the solvent contacts your eyes, wash them with water immediately and obtain medical aid (ref. FM 21-11).

NOTE

Perform steps 1 and 2 only if faceplate was removed.

- 1 Clean cover (5) with dry-cleaning solvent and wire brush.
- 2 Remove backing from faceplate (41) and press into place on cover (5).
- 3 Install CONTROL switch (37) in cover (5) with new seal (40), lockwasher (39) and nut (38).
- 4 Connect six wires (35) to six terminals (36) on CONTROL switch (37) with six screws (32), six lockwashers (33) and six flat washers (34).
- 5 Install POWER switch (28) in cover (5) with new seal (31), lockwasher (30) and nut (29).
- 6 Connect two wires (26) to two terminals (27) on POWER switch (28) with screws (23), two lockwashers (24) and two flat washers (25).
- 7 Install relay (22) on gun tube travel lock control box cover (5) with two screws (19), two new lockwashers (21) and two nuts (20).
- 8 Solder wires (17) to relay terminals (18).

Section II. INSTRUMENT OR ENGINE CONTROL PANELS - CONTINUED

7-2 GUN TUBE TRAVEL LOCK CONTROL BOX ASSEMBLY - CONTINUED

b. Assembly - Continued

- 9 Install three indicator light housings (2) on gun tube travel lock control box cover (5) with three lockwashers (16) and three nuts (15).
- 10 Solder two wires (13) to each terminal (14) on three indicator light housings (2).
- 11 Solder one wire (11) to each terminal (12) on three indicator light housings (2).
- 12 Install new gasket (10) and cable assembly (9) into gun tube travel lock control box housing (6) with flange (8) and four screws (7).
- 13 Install gun tube travel lock control box cover (5) on gun tube travel lock control box housing (6) with two screws (4).

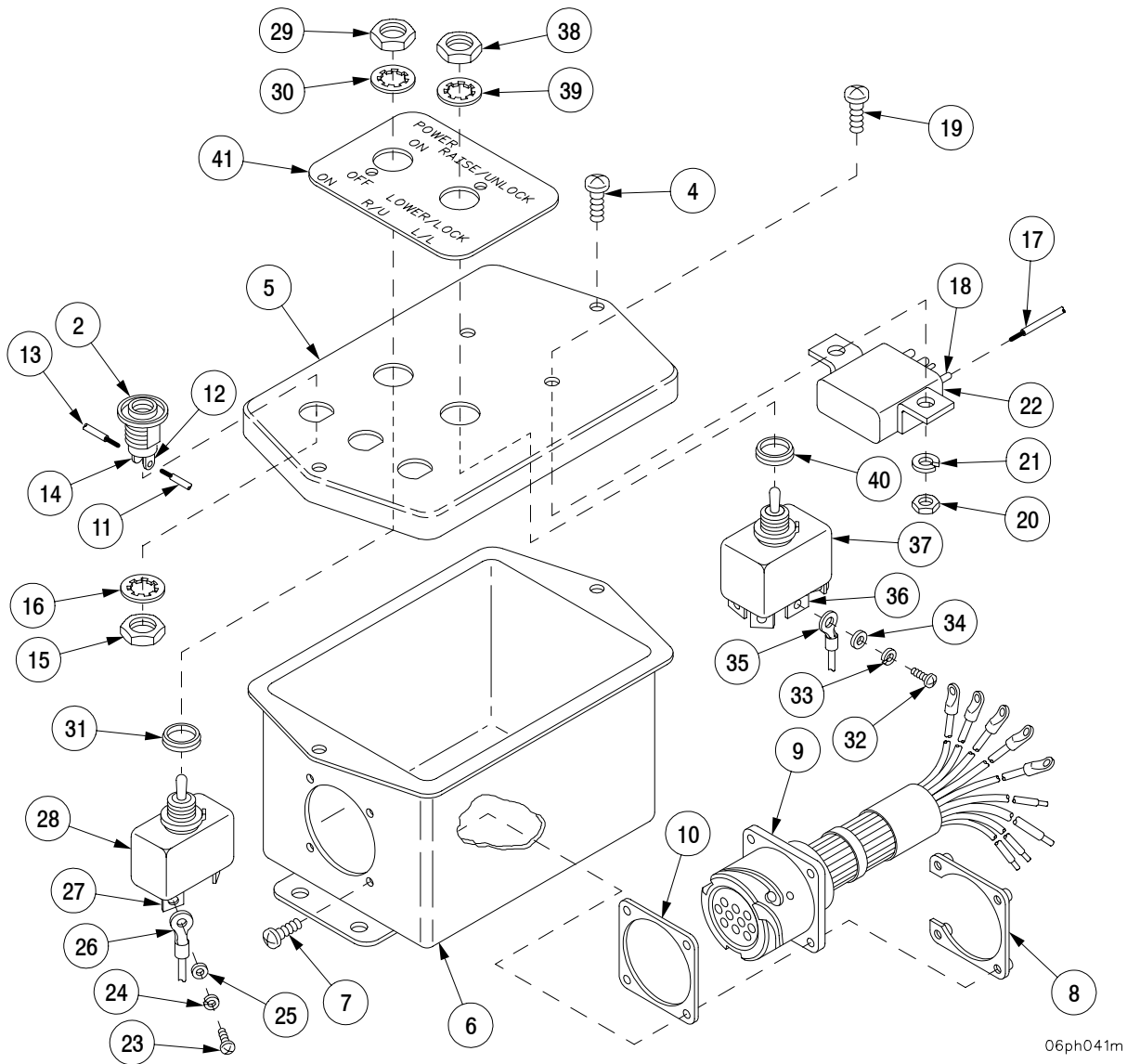

06ph041m

Section II. INSTRUMENT OR ENGINE CONTROL PANELS - CONTINUED

7-2 GUN TUBE TRAVEL LOCK CONTROL BOX ASSEMBLY - CONTINUED

b. Assembly - Continued

- 14 Install three LEDs (3) in three lenses (1).
- 15 Install three lenses (1) on three indicator light housings (2).
- 16 Perform test using 24 V dc power source.

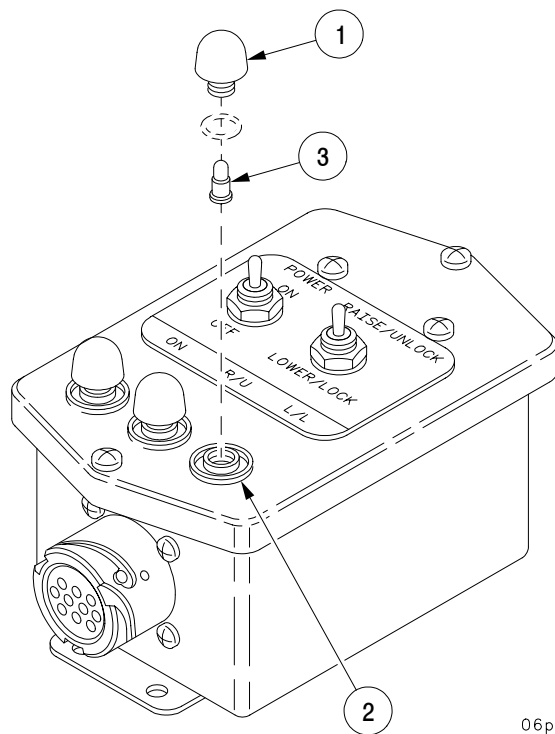

06ph039m

NOTE

FOLLOW-ON MAINTENANCE:
Install gun tube travel lock control box assembly
(TM 9-2350-314-20-1-2)

Section II. INSTRUMENT OR ENGINE CONTROL PANELS - CONTINUED

7-3 VOLTAGE REGULATOR CONTROL BOX ASSEMBLY.

This task covers: a. Disassembly b. Assembly

INITIAL SETUP

Tools

Fuel and electrical tool kit
(SC 5180-95-B08)
Soldering gun (item 49, Appx F)
Wire brush (item 8, Appx F)

Materials/Parts

Gasket (item 14, Appx E)
Lockwashers (2) (item 68, Appx E)
Solder (item 28, Appx B)
Flux, soldering (item 10, Appx B)
Dry-cleaning solvent (item 29, Appx B)

Equipment Conditions

Voltage regulator control box assembly
removed (TM 9-2350-314-20-1-2)

References

TB SIG 222
TM 9-2350-314-20-1-2

NOTE

- To replace indicator light housing, perform Disassembly steps 1 thru 5 and Assembly steps 10 thru 14.
- To replace relay, perform Disassembly steps 3, 6 and 7 and Assembly steps 8, 9 and 12.
- To replace cable assembly, perform Disassembly steps 3, 8 and 9 and Assembly steps 6, 7 and 12.
- To replace circuit breaker, perform Disassembly steps 3, 10 and 11 and Assembly steps 4, 5 and 12.
- To replace guard, perform Disassembly steps 3, 11 and 12 and Assembly steps 3, 4, and 12.
- To replace faceplate, perform Disassembly steps 1 thru 5 and 11 thru 13 and Assembly steps 1 thru 4 and steps 10 thru 14.

Section II. INSTRUMENT OR ENGINE CONTROL PANELS - CONTINUED

7-3 VOLTAGE REGULATOR CONTROL BOX ASSEMBLY - CONTINUED

a. Disassembly.

- 1 Remove lens (1) from indicator light housing (2).
- 2 Remove LED (3) from lens (1).

NOTE

An o-ring is installed on lens (1) as part of the lens. If this o-ring is damaged or missing, the lens must be replaced.

- 3 Remove two screws (4) and separate voltage regulator control box cover (5) from voltage regulator control box housing (6).

NOTE

- Refer to electrical schematic foldouts for internal voltage regulator control box wiring.
 - Prior to unsoldering wires, tag all electrical connections to ensure proper installation.
 - Before proceeding, see detailed instructions on soldering and solder (TB SIG 222).
- 4 Unsolder and remove one wire (7) from each terminal (8) on indicator light housing (2).
 - 5 Remove nut (9), lockwasher (10), and indicator light housing (2) from voltage regulator control box cover (5).
 - 6 Unsolder and remove wires (11) from relay terminals (12).
 - 7 Remove two screws (13), two nuts (14), two lockwashers (15), two flat washers (16), and relay (17) from voltage regulator control box cover (5). Discard lockwashers.
 - 8 Remove four screws (18), flange (19), cable assembly (20), and gasket (21) from voltage regulator control box housing (6). Discard gasket.

Section II. INSTRUMENT OR ENGINE CONTROL PANELS - CONTINUED

7-3 VOLTAGE REGULATOR CONTROL BOX ASSEMBLY - CONTINUED

a. Disassembly - Continued

- 9 Unsolder wires (22) from cable assembly (20).
- 10 Unsolder wires (23) from circuit breaker terminals (24).
- 11 Remove nut (25), lockwasher (26), locking tab (27) and circuit breaker (28) from voltage regulator control box cover (5).

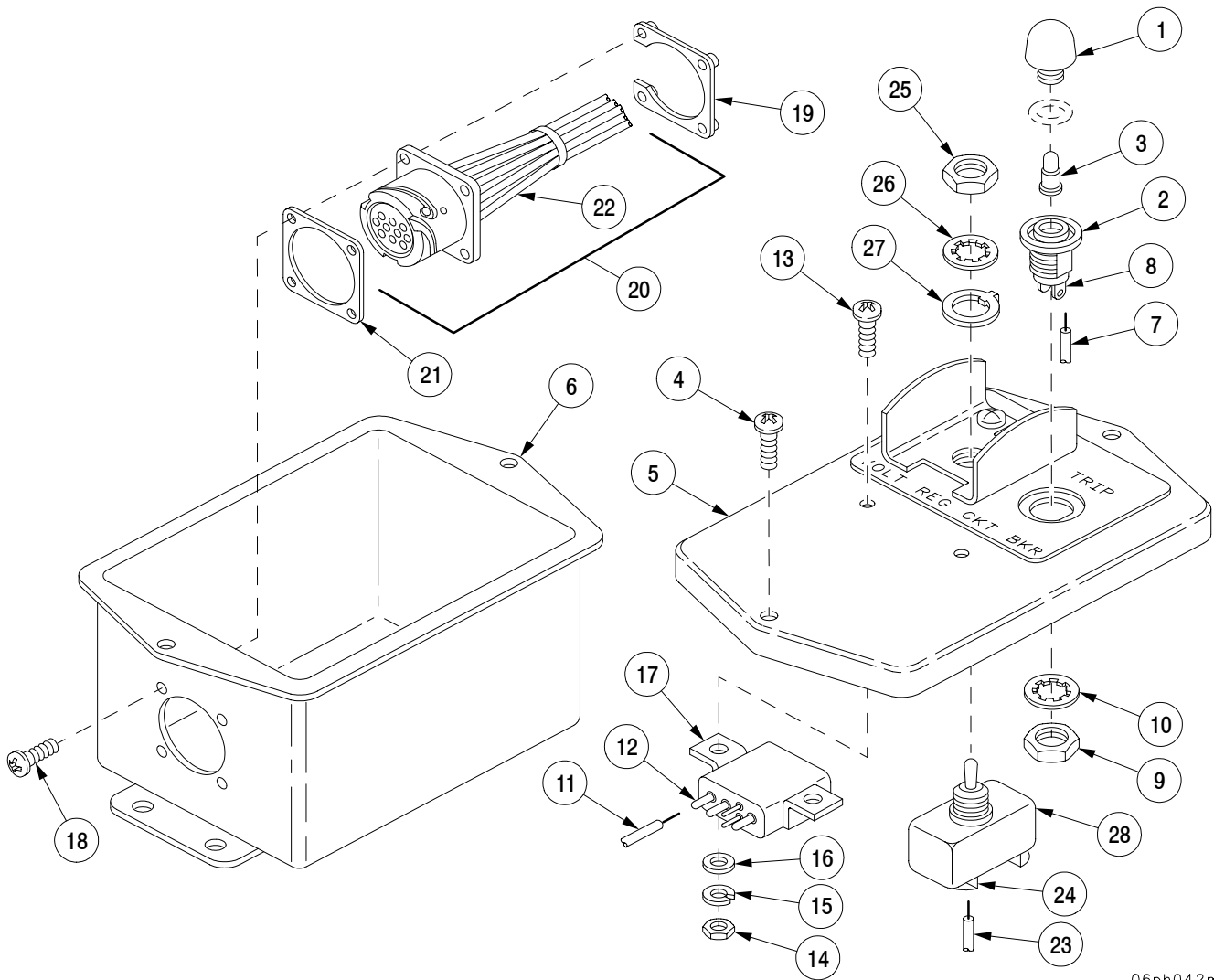

06ph042m

Section II. INSTRUMENT OR ENGINE CONTROL PANELS - CONTINUED

7-3 VOLTAGE REGULATOR CONTROL BOX ASSEMBLY - CONTINUED

a. Disassembly - Continued

- 12 Remove two screws (29) and guard (30) from voltage regulator control box cover (5).

NOTE

Faceplate is to be replaced only if damaged or illegible.

- 13 Remove faceplate (31) from voltage regulator control box cover (5).

b. Assembly.

WARNING

Dry-cleaning solvent (P-D-680), used to clean parts, is toxic and flammable. Wear protective goggles and gloves and use only in a well-ventilated area. Avoid contact with skin, eyes, and clothes. Do not breathe vapors. Do not use near open flame or excessive heat. Do not smoke when using solvent. Failure to do so could casue SERIOUS INJURY. If you become dizzy while using dry-cleaning solvent, get fresh air immediately, and if necessary, get medical attention. If contact with skin or clothes is made, flush thoroughly with water. If the solvent contacts your eyes, wash them with water immediately and obtain medical aid (ref. FM 21-11).

NOTE

Perform steps 1 and 2 only if faceplate was removed.

- 1 Clean voltage regulator control box cover (5) with dry-cleaning solvent and wire brush.

Section II. INSTRUMENT OR ENGINE CONTROL PANELS - CONTINUED

7-3 VOLTAGE REGULATOR CONTROL BOX ASSEMBLY - CONTINUED

b. Assembly - Continued

- 2 Remove backing from faceplate (31) and press into place on voltage regulator control box cover (5).
- 3 Install guard (30) on voltage regulator control box cover (5) with two screws (29).

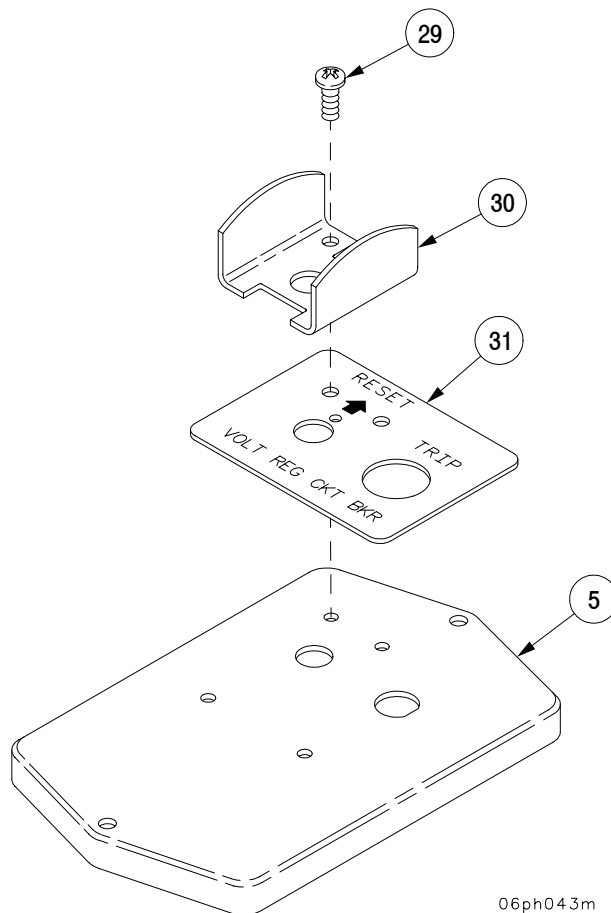

06ph043m

Section II. INSTRUMENT OR ENGINE CONTROL PANELS - CONTINUED

7-3 VOLTAGE REGULATOR CONTROL BOX ASSEMBLY - CONTINUED

b. Assembly - Continued

- 4 Install circuit breaker (28) on voltage regulator control box cover (5) with locking tab (27), lockwasher (26) and nut (25).

NOTE

Before proceeding, see detailed instructions on soldering and solder (TB SIG 222).

- 5 Solder wires (23) to circuit breaker terminals (24).
- 6 Solder wires (22) to cable assembly (20).
- 7 Install cable assembly (20) in voltage regulator control box housing (6) with new gasket (21), flange (19), and four screws (18).
- 8 Install relay (17) on voltage regulator control box cover (5) with two screws (13), two flat washers (16), two new lockwashers (15), and two nuts (14).
- 9 Solder wires (11) to relay terminals (12).
- 10 Install indicator light housing (2) in voltage regulator control box cover (5) with lockwasher (10) and nut (9).
- 11 Solder one wire (7) to each terminal (8) on indicator light housing (2).
- 12 Install voltage regulator control box cover (5) on voltage regulator control box housing (6) with two screws (4).
- 13 Install LED (3) in lens (1).
- 14 Install lens (1) on indicator light housing (2).
- 15 Perform test using 24 V dc power source.

Section II. INSTRUMENT OR ENGINE CONTROL PANELS - CONTINUED

7-3 VOLTAGE REGULATOR CONTROL BOX ASSEMBLY - CONTINUED

b. Assembly - Continued

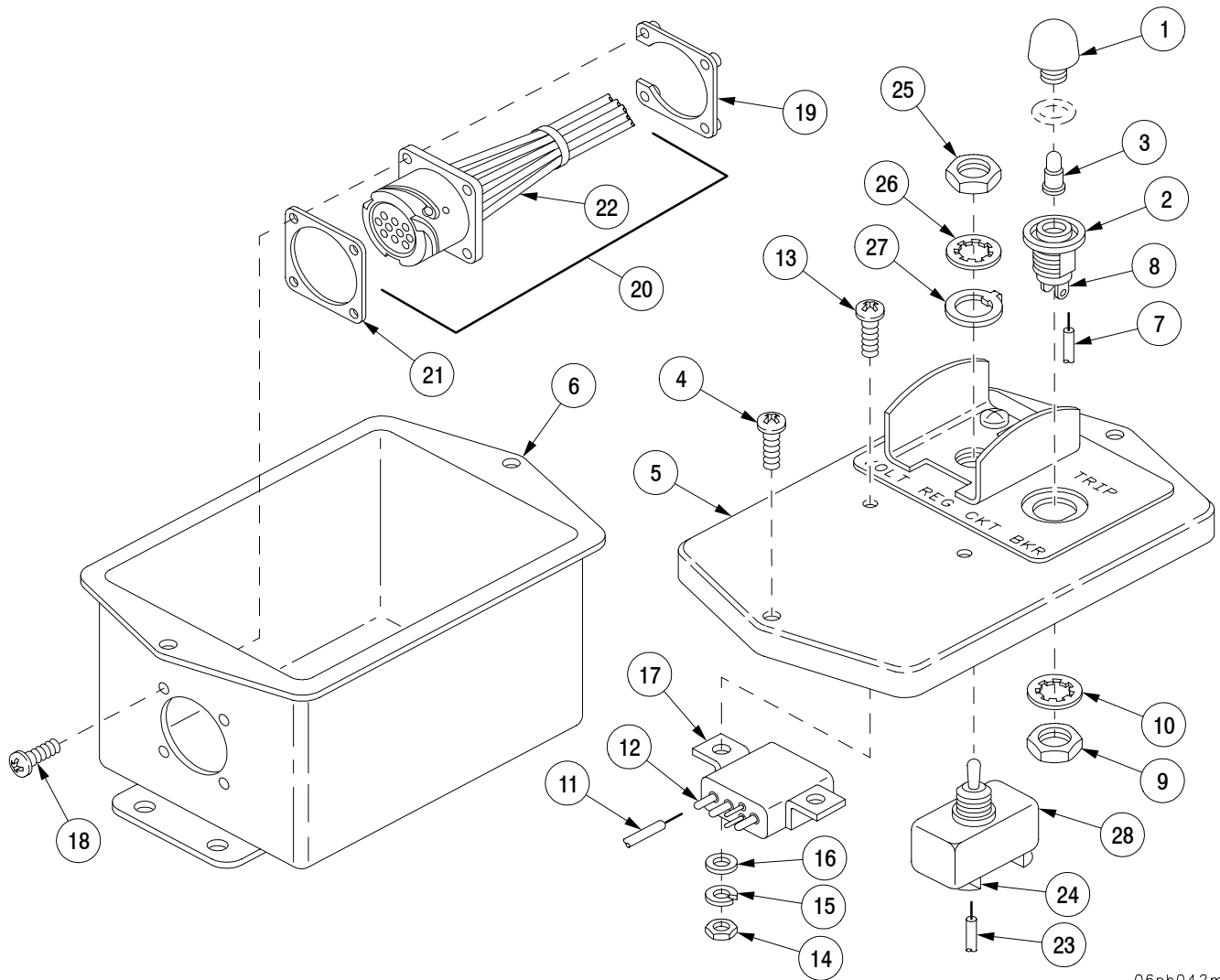

06ph042m

Section II. INSTRUMENT OR ENGINE CONTROL PANELS - CONTINUED

7-4 ENCLOSURE ASSEMBLY — CREW COMPARTMENT WARNING LIGHT.

This task covers: a. Disassembly b. Assembly

INITIAL SETUP

Tools

Fuel and electrical tool kit
(SC 5180-95-B08)
Soldering gun (item 49, Appx F)

Materials/Parts

Gasket (item 38, Appx E)
Lockwashers (4) (item 70, Appx E)
Lockwasher (item 65, Appx E)
Solder (item 28, Appx B)
Soldering flux (item 10, Appx B)

Equipment Conditions

Enclosure assembly removed
(TM 9-2350-314-20-1-2)

References

TB SIG 222
TM 9-2350-314-20-1-2

a. Disassembly.

- 1 Remove lens (1) and lamp (2) from enclosure housing (3).
- 2 Remove two screws (4) and cover (5) from enclosure housing (3).
- 3 Remove four screws (6), four lockwashers (7), and four nuts (8) securing connector (9) to enclosure housing (3). Discard lockwashers.

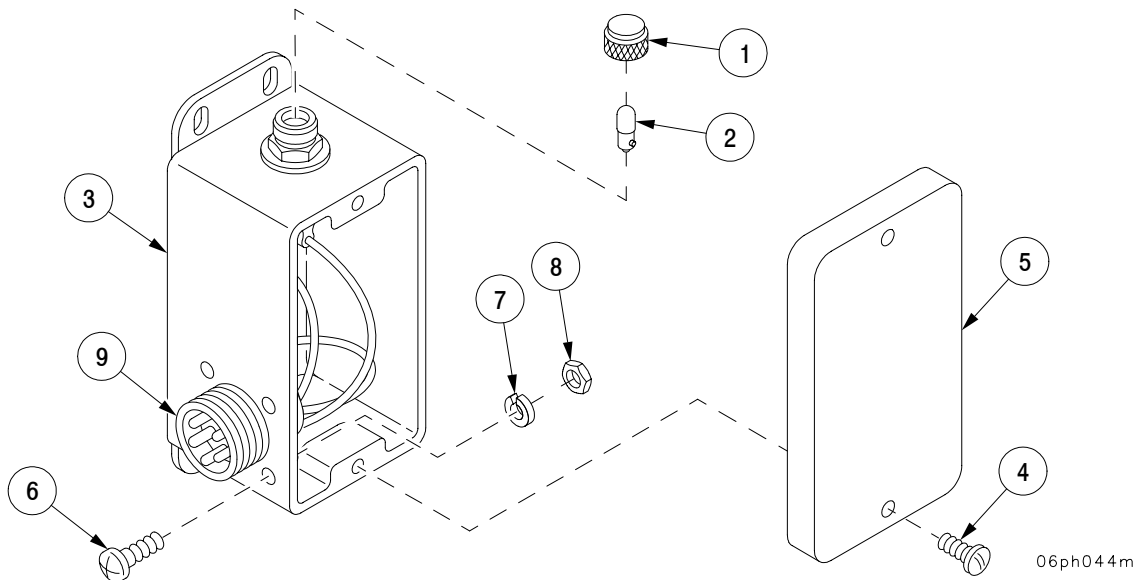

Section II. INSTRUMENT OR ENGINE CONTROL PANELS - CONTINUED

7-4 ENCLOSURE ASSEMBLY — CREW COMPARTMENT WARNING LIGHT - CONTINUED

a. Disassembly - Continued

- 4 Remove nut (10), lockwasher (11) and light assembly (12) from enclosure housing (3).
- 5 Remove nut (13), lockwasher (14), and strap (15) securing diode assembly (16).
- 6 Remove connector (9), gasket (17), diode assembly (16), and light assembly (12) from enclosure housing (3). Discard gasket.
- 7 Slide insulation sleeving (18) from soldered connections of two wires (19) and diode assembly wire (20).

NOTE

- Tag electrical wires to ensure proper installation.
 - Before proceeding, see detailed instructions on soldering and solder (TB SIG 222).
- 8 Unsolder two wires (19) and diode assembly wire (20) from light assembly (12). Remove insulation sleeving (18).
 - 9 Unsolder two wires (19) and two diode assembly wires (21) from connector (9).

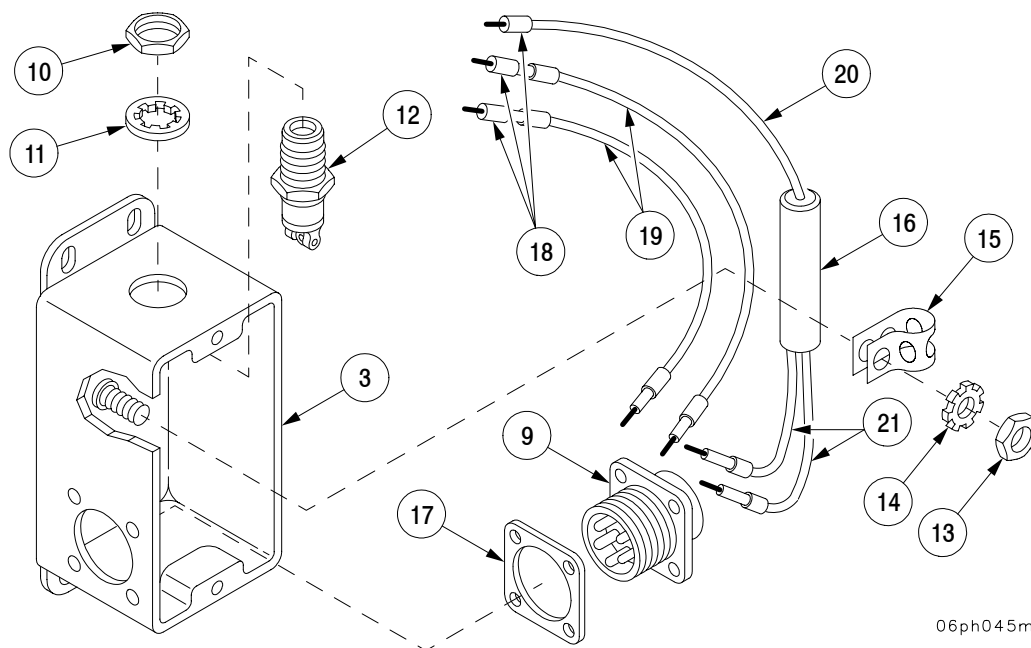

Section II. INSTRUMENT OR ENGINE CONTROL PANELS - CONTINUED

7-4 ENCLOSURE ASSEMBLY — CREW COMPARTMENT WARNING LIGHT - CONTINUED

b. Assembly.

NOTE

Before proceeding, see detailed instructions on soldering and solder (TB SIG 222).

- 1 Solder two wires (19) and two diode assembly wires (21) to connector (9).
- 2 Install insulation sleeving (18) on two wires (19) and diode assembly wire (20).
- 3 Solder two wires (19) and diode assembly wire (20) to light assembly (12).
- 4 When solder has cooled, slide insulation sleeving (18) onto terminals.
- 5 Install connector (9), gasket (17), diode assembly (16), and light assembly (12) in enclosure housing (3).
- 6 Install four screws (6), four new lockwashers (7), and four nuts (8) to secure connector (9) in enclosure housing (3).
- 7 Secure diode assembly (16) to enclosure housing (3) with strap (15), new lockwasher (14), and nut (13).
- 8 Secure light assembly (12) in enclosure housing (3) with lockwasher (11) and nut (10).

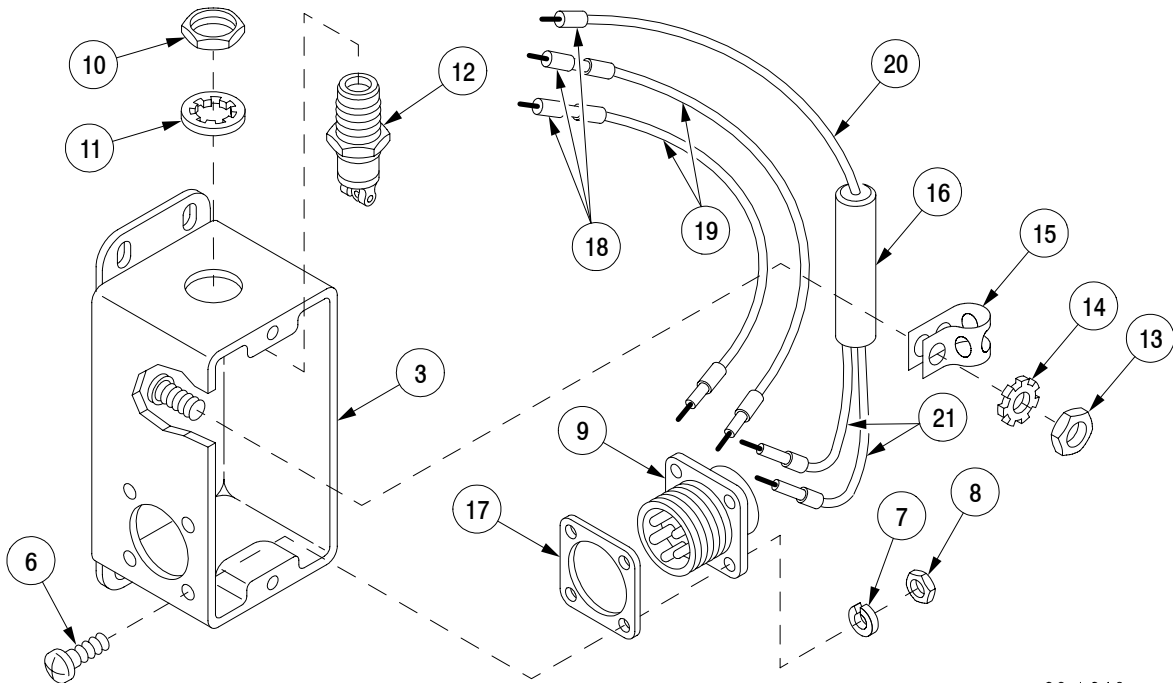

06ph046m

Section II. INSTRUMENT OR ENGINE CONTROL PANELS - CONTINUED

7-4 ENCLOSURE ASSEMBLY — CREW COMPARTMENT WARNING LIGHT - CONTINUED

b. Assembly - Continued

- 9 Install lamp (2) and lens (1) on enclosure housing (3).
- 10 Perform test using 24 volt power source to ensure lamp (2) and diode assembly (16) works properly.
- 11 Install cover (5) on enclosure housing (3) with two screws (4).

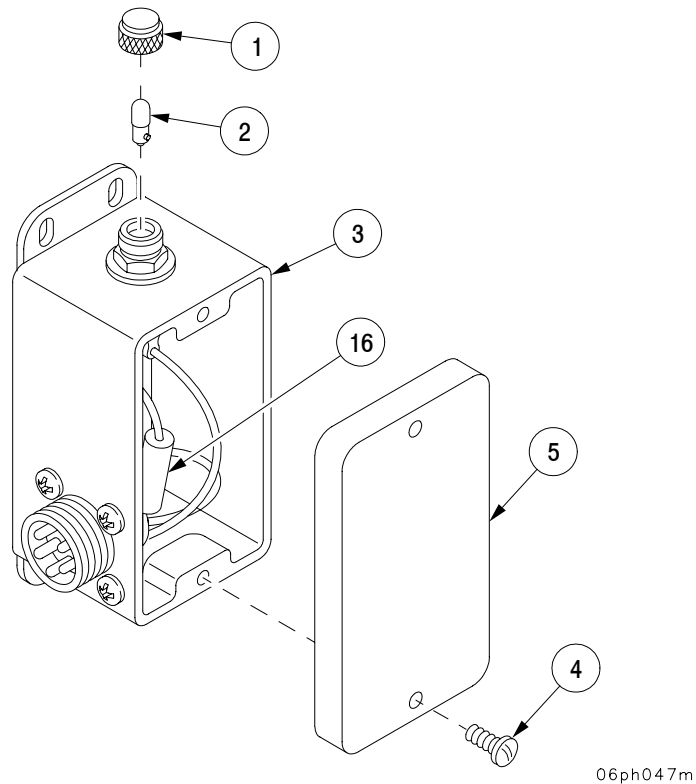
**NOTE****FOLLOW-ON MAINTENANCE:**

Install enclosure assembly
(TM 9-2350-314-20-1-2)

Section II. INSTRUMENT OR ENGINE CONTROL PANELS - CONTINUED

7-5 ACCESSORY CONTROL BOX (P/N 12268582).

This task covers: a. Disassembly b. Assembly

INITIAL SETUP

Tools

Fuel and electrical tool kit
(SC 5180-95-B08)
Soldering gun (item 49, Appx F)
Hand riveter (item 37, Appx F)
Tubing (item 52, Appx F)
Purging kit (item 28, Appx F)
Insulation (item 60, Appx F)

Equipment Conditions

Accessory control box removed
(TM 9-2350-314-20-1-2)

References

TM 9-2350-314-20-1-2

Materials/Parts

Lockwashers (16) (item 72, Appx E)
Lockwashers (12) (item 77, Appx E)
Gasket (item 4, Appx E)
Lockwashers (2) (item 58, Appx E)
Tiedown straps (2) (item 56, Appx E)
Lockwashers (2) (item 69, Appx E)
Lockwashers (2) (item 64, Appx E)
Lockwashers (2) (item 59, Appx E)
Lockwashers (4) (item 73, Appx E)
Lockwashers (8) (item 76, Appx E)
Rivets (8) (item 47, Appx E)
Lockwashers (2) (item 82, Appx E)
Lockwashers (4) (item 67, Appx E)
Lockwasher (item 36, Appx E)
Lockwasher (item 39, Appx E)
Solder (item 28, Appx B)
Soldering flux (item 10, Appx B)
Distilled water (item 32, Appx B)
Silicone compound (item 34, Appx B)

NOTE

- The procedures in this task are for vehicles with Accessory Control Box P/N 12268582.
- See para 7-5A for the task that covers the procedures for vehicles with Accessory Control Box P/N 12268547.

a. Disassembly.

- 1 Remove 12 screws (1), 12 nuts (2), 12 lockwashers (3), 12 flat washers (4), cover (5), and gasket (6) from accessory control box body (7). Discard gasket and lockwashers.

Section II. INSTRUMENT OR ENGINE CONTROL PANELS - CONTINUED

7-5 ACCESSORY CONTROL BOX (P/N 12268582) - CONTINUED

a. Disassembly - Continued

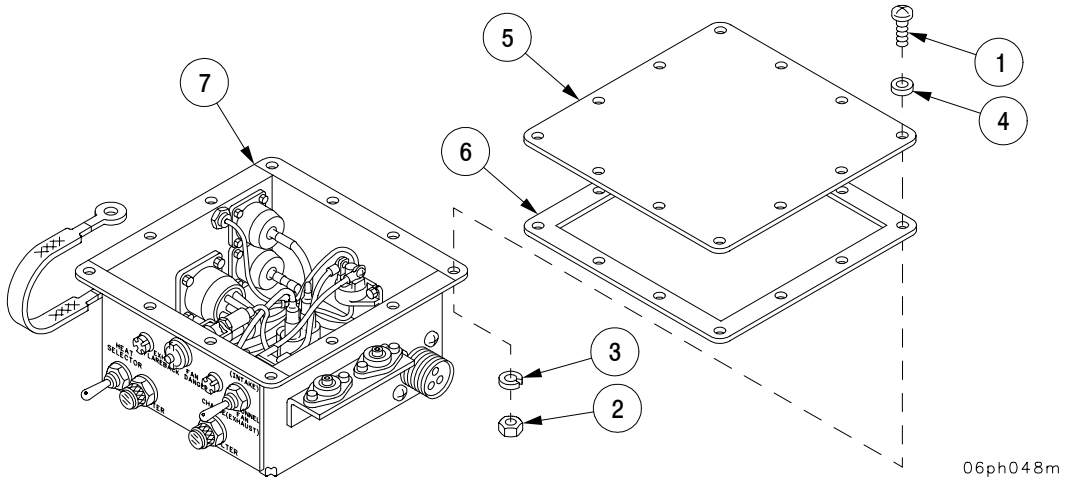

NOTE

- Refer to electrical schematic foldouts for internal accessory control box wiring.
- Tag all electrical connections and electrical leads prior to removal to aid in installation.

2 Remove four electrical leads (8, 9, 10, and 11) from two circuit breakers (12).

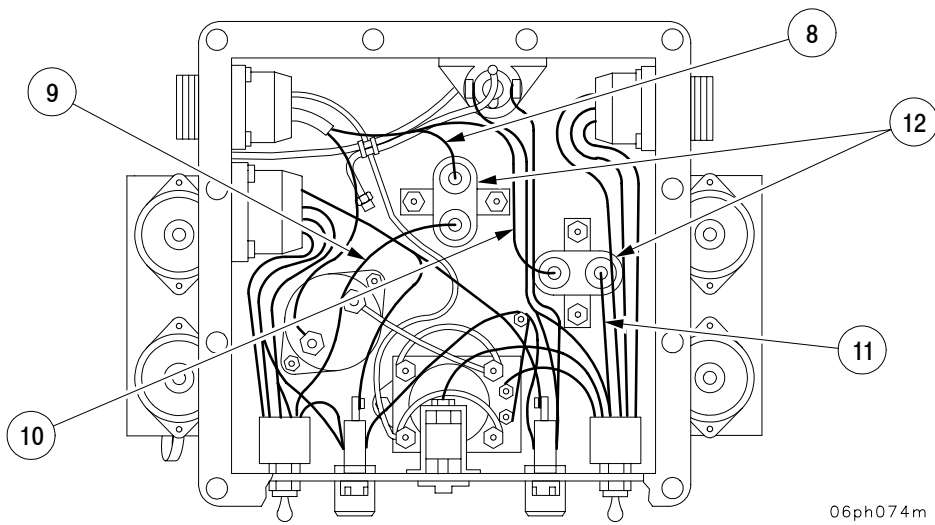

Section II. INSTRUMENT OR ENGINE CONTROL PANELS - CONTINUED

7-5 ACCESSORY CONTROL BOX (P/N 12268582) - CONTINUED

a. Disassembly - Continued

- 3 Remove four screws (13), four nuts (14), four lockwashers (15), four flat washers (16), and two circuit breakers (12) from accessory control box body (7). Discard lockwashers.
- 4 Remove two screws (17), four lockwashers (18), and two leads (19 and 20) from circuit breaker (21). Discard lockwashers.
- 5 Remove two screws (22), two nuts (23), two lockwashers (24), two flat washers (25), and circuit breaker (21) from accessory control box body (7). Discard lockwashers.

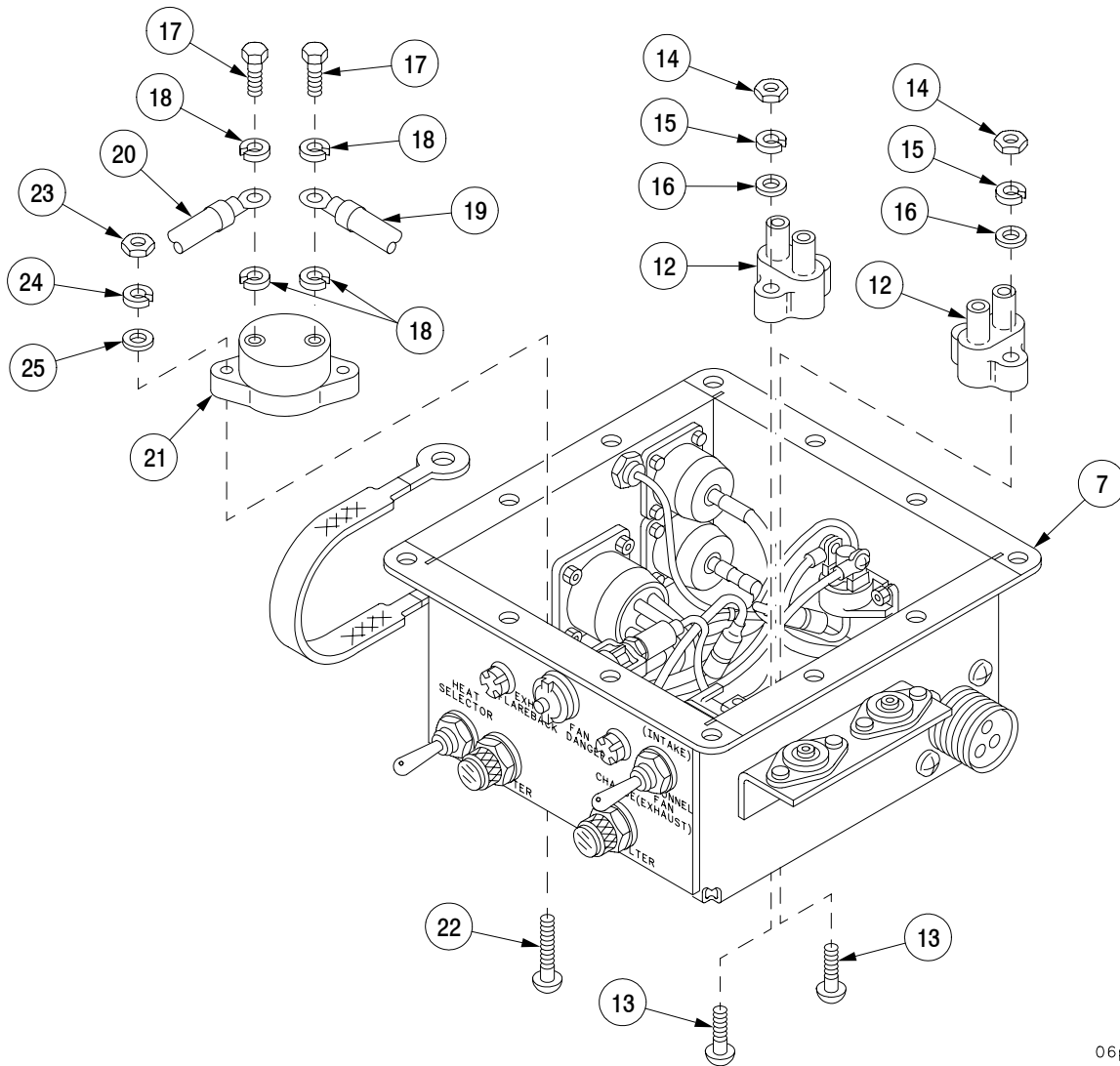

06ph049m

Section II. INSTRUMENT OR ENGINE CONTROL PANELS - CONTINUED

7-5 ACCESSORY CONTROL BOX (P/N 12268582) - CONTINUED

a. Disassembly - Continued

- 6 Remove nut (26), lockwasher (27), flat washer (28), and lead (29) from terminal X1 of relay (30). Discard lockwasher.
- 7 Remove nut (26), lockwasher (27), flat washer (28), and ground lead (31) from terminal X2 of relay (30). Discard lockwasher.
- 8 Remove nut (32), lockwasher (33), flat washer (34), and two leads (19 and 35) from terminal A1 of relay (30). Discard lockwasher.
- 9 Remove lead (19) from accessory control box body (7).
- 10 Remove nut (32), lockwasher (33), flat washer (34), and two leads (36 and 37) from terminal B2 of relay (30). Discard lockwasher.
- 11 Remove nut (32), lockwasher (33), flat washer (34), and lead (35) from terminal B1 of relay (30). Discard lockwasher.
- 12 Remove lead (35) from accessory control box body (7).
- 13 Remove nut (32), lockwasher (33), flat washer (34), and lead (37) from terminal A2 of relay (30). Discard lockwasher.
- 14 Remove lead (37) from accessory control box body (7).
- 15 Remove two screws (38), two nuts (39), two lockwashers (40), two flat washers (41), and relay (30) from accessory control box body (7). Discard lockwashers.

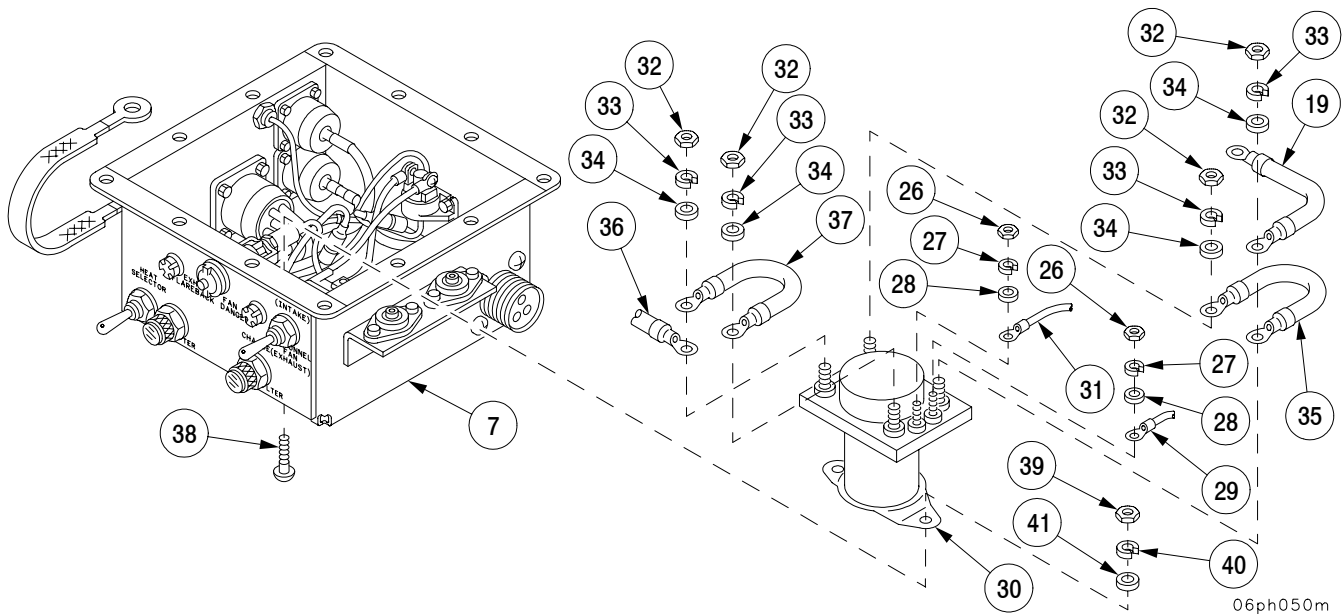

Section II. INSTRUMENT OR ENGINE CONTROL PANELS - CONTINUED

7-5 ACCESSORY CONTROL BOX (P/N 12268582) - CONTINUED

a. Disassembly - Continued

- 16 Remove two screws (42), two nut (43), two lockwashers (44), two flat washers (45), and two leads (46 and 47) from pressure switch (48). Discard lockwashers.
- 17 Remove two tubes (49 and 50) from pressure switch (48).
- 18 Remove two screws (51), two nuts (52), two lockwashers (53), two flat washers (54), and pressure switch (48) from accessory control box body (7). Discard lockwashers.
- 19 Remove two straps (55) and two tubes (49 and 50) from two fittings (56 and 57). Discard straps.
- 20 Remove nut (58) from fitting (56) and remove fittings (56 and 57) from accessory control box body (7).
- 21 Remove screw (59), two lockwashers (60), and two nuts (61) securing ground lead (31) and two ground leads (62) to accessory control box body (7). Discard lockwashers.
- 22 Remove ground lead (31) from accessory control box body (7).

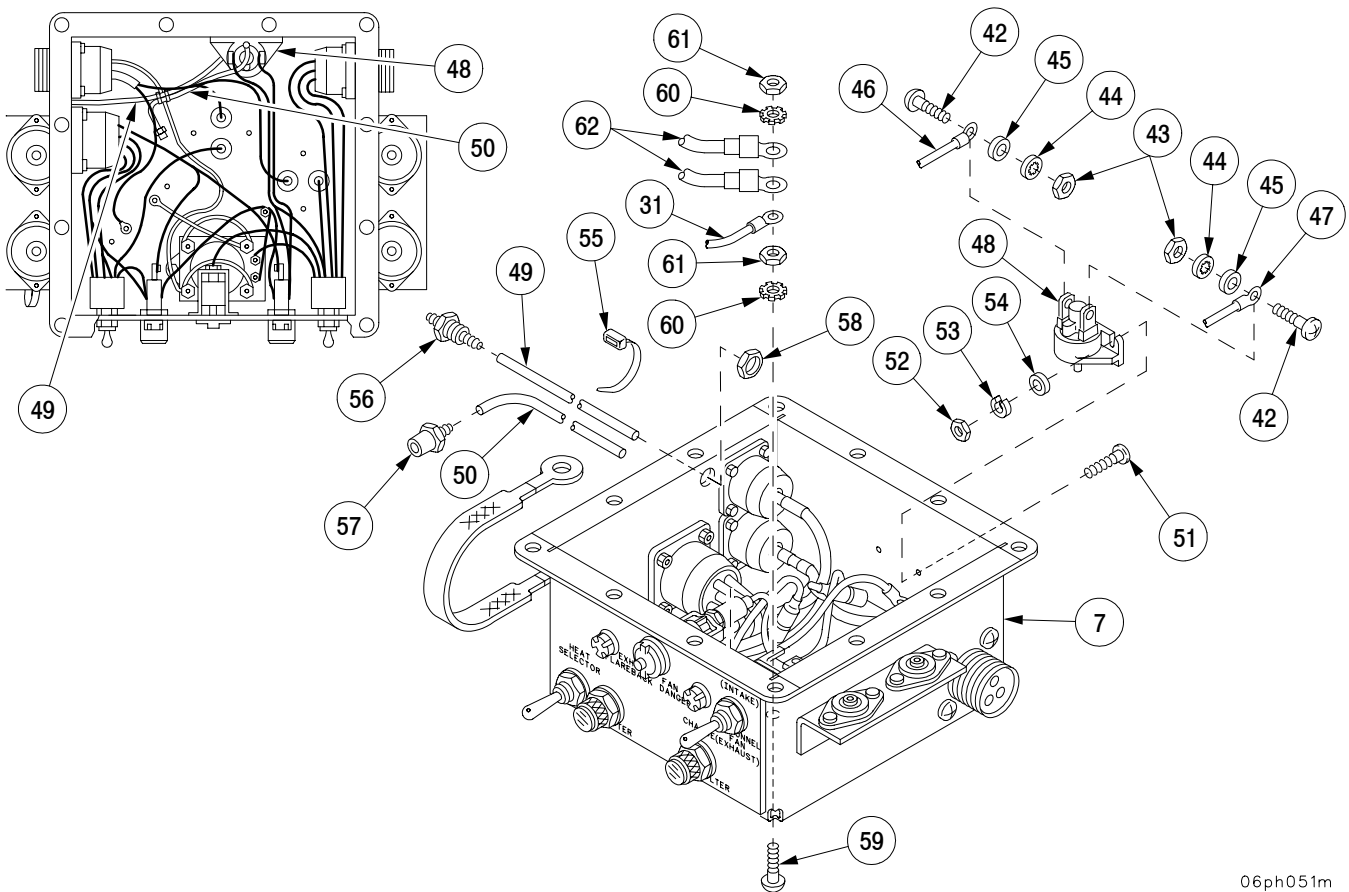

06ph051m

Section II. INSTRUMENT OR ENGINE CONTROL PANELS - CONTINUED

7-5 ACCESSORY CONTROL BOX (P/N 12268582) - CONTINUED

a. Disassembly - Continued

- 23 Remove lead (63) from lamp assembly (64).
- 24 Remove lens cap (65), gasket (66), and lamp (67) from lamp assembly (64).
- 25 Remove nut (68), lockwasher (69), and switch (70) from accessory control box body (7).
- 26 Remove leads (11, 29, 46, 63, 71, 72, and 73) and jumper lead (74) from fan switch (70) by removing six screws (75) and six lockwashers (76).
- 27 Remove leads (11, 29, and 63) from accessory control box body (7).
- 28 Remove nut (68), lockwasher (69), and switch (77) from accessory control box body (7).
- 29 Remove leads (9, 78, 79, 80, 81, and 82) from HEAT SELECTOR switch (77), by removing five screws (83) and five lockwashers (84).
- 30 Remove lead (9) from accessory control box body (7).

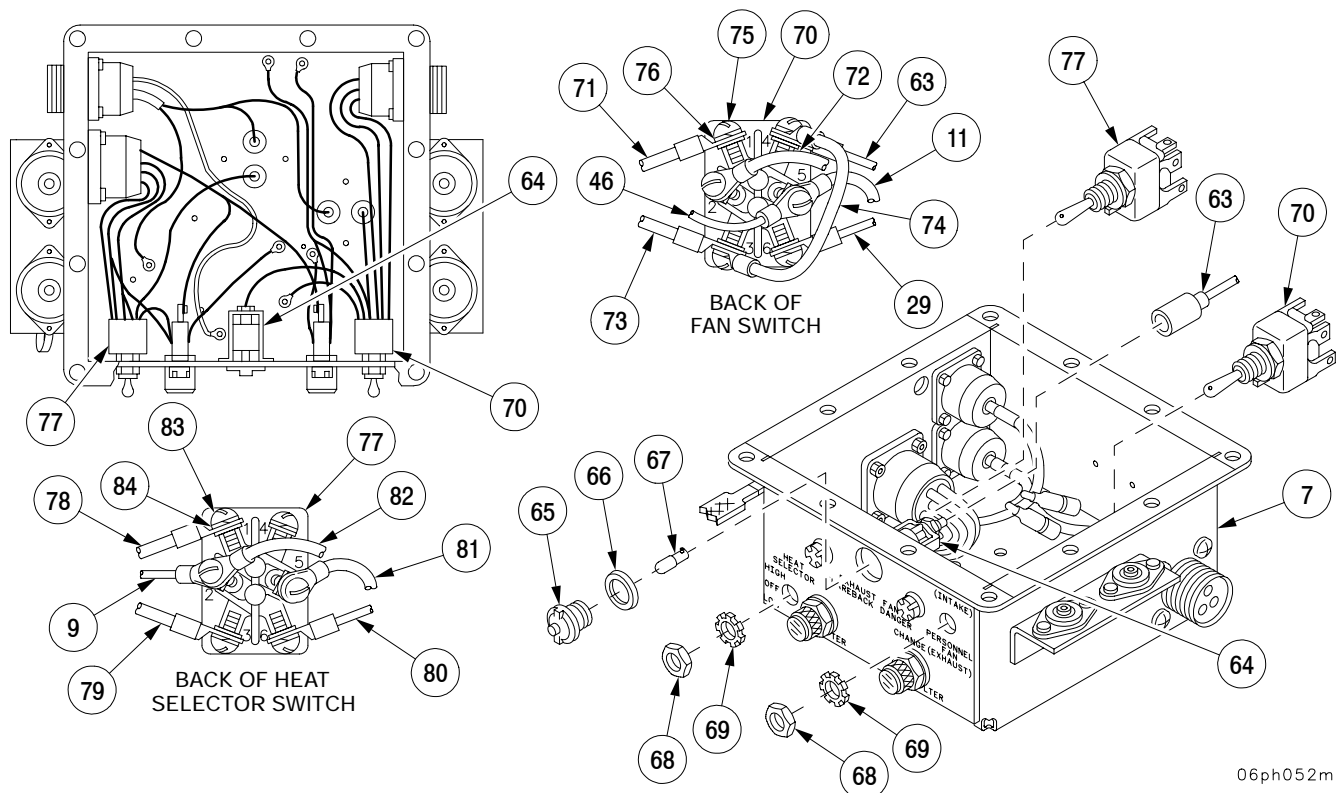

Section II. INSTRUMENT OR ENGINE CONTROL PANELS - CONTINUED

7-5 ACCESSORY CONTROL BOX (P/N 12268582) - CONTINUED

a. Disassembly - Continued

- 31 Remove two panel light lens caps (85) with seals and two lamps (86), two screws (87), two lockwashers (88) and lead (89) from two panel light brackets (90).

NOTE

To remove electrical connector from lamp assembly, unsolder points of connection.

- 32 Unsolder leads (46, 47, 62, 91 and 92) from two indicator lamp bases (93).
- 33 Remove insulation (94) from leads (46, 47, 62, 91 and 92).
- 34 Remove leads (46 and 47) and two leads (62) from accessory control box body (7).
- 35 Remove two indicator lens caps (95), two lamps (96), two nuts (97), two lockwashers (98), two indicator lamp bases (93) and front panel (99) from accessory control box body (7).
- 36 Remove two nuts (100), two lockwashers (101) and two panel light brackets (90) from accessory control box body (7). Discard lockwashers.
- 37 Remove two screws (102), two lockwashers (103) and lamp assembly (64) from accessory control box body (7). Discard lockwashers.

Section II. INSTRUMENT OR ENGINE CONTROL PANELS - CONTINUED

7-5 ACCESSORY CONTROL BOX (P/N 12268582) - CONTINUED

a. Disassembly - Continued

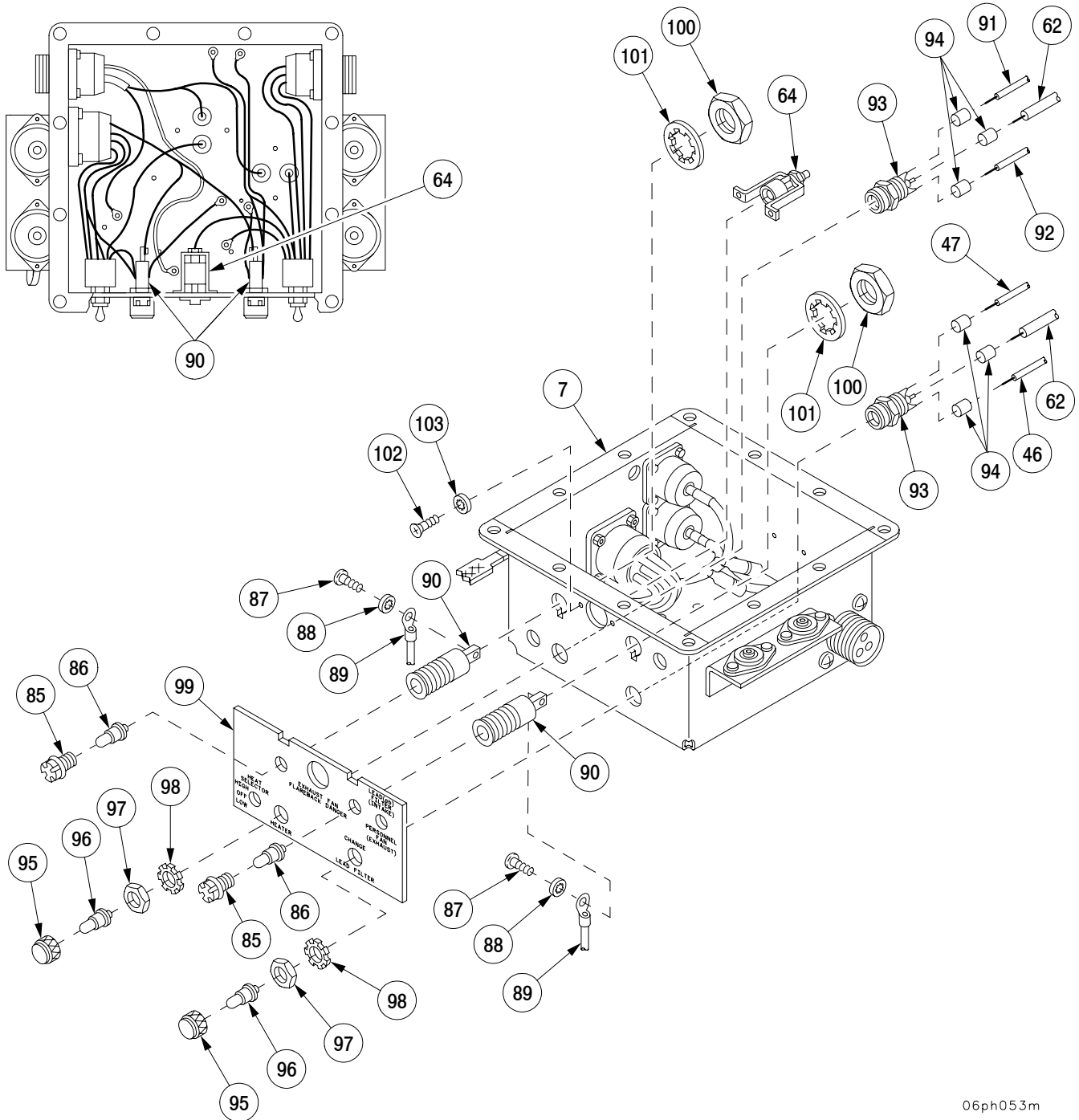

06ph053m

Section II. INSTRUMENT OR ENGINE CONTROL PANELS - CONTINUED

7-5 ACCESSORY CONTROL BOX (P/N 12268582) - CONTINUED

a. Disassembly - Continued

- 38 Remove 16 screws (104), 16 nuts (105), 16 lockwashers (106), 16 flat washers (107) and four lead assemblies (36, 108, 109, and 110) from accessory control box body (7). Discard lockwashers.

NOTE

There are four cushions used on accessory control box. All cushions are removed in the same manner. A ground lead is attached to a cushion. Note location to aid in installation of ground lead.

- 39 Remove two rivets (111), ground lead (112), and cushion (113) from accessory control box body (7). Discard rivets.
- 40 Remove six rivets (111) and three cushions (113) from accessory control box body (7). Discard rivets.

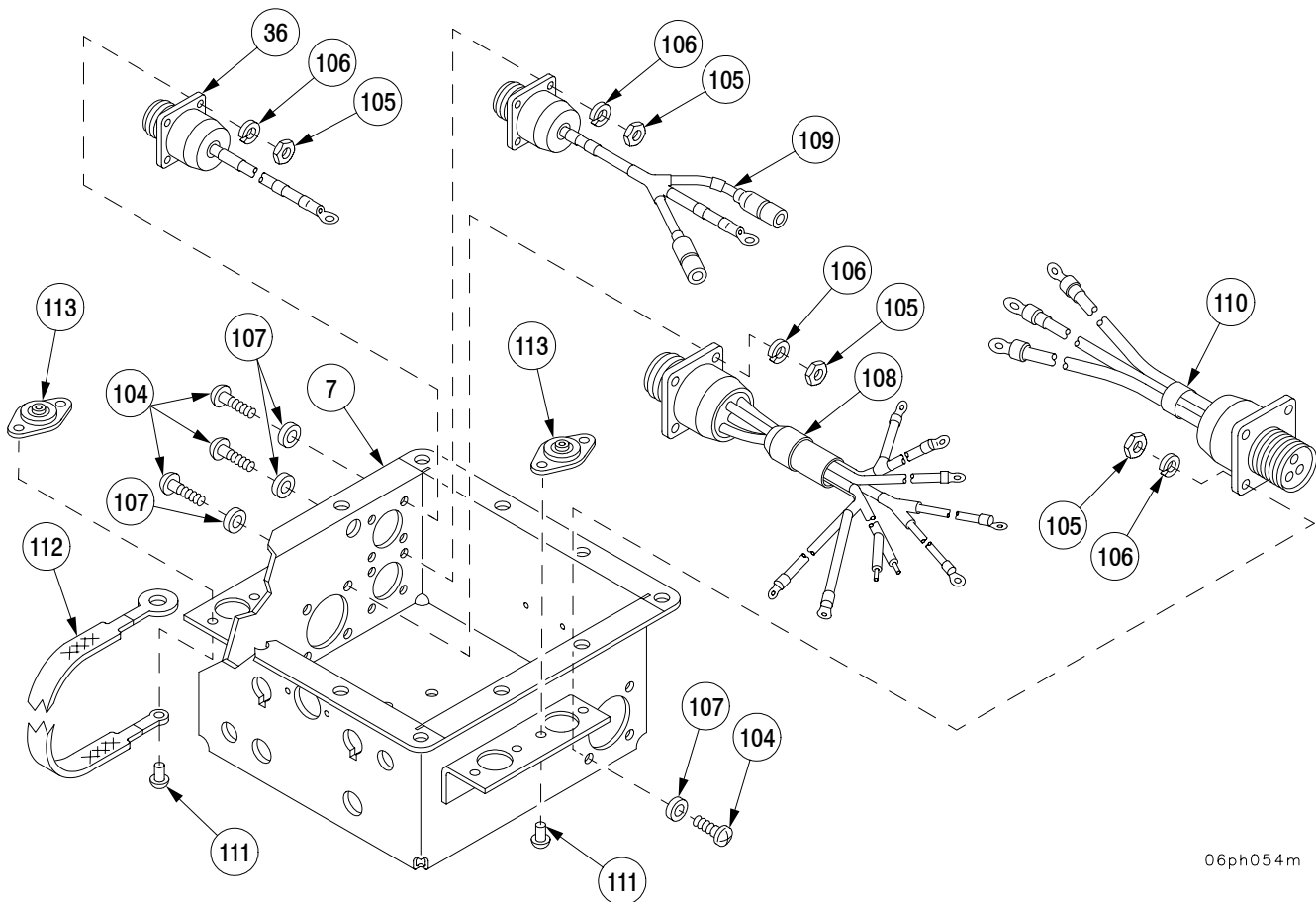

06ph054m

Section II. INSTRUMENT OR ENGINE CONTROL PANELS - CONTINUED

7-5 ACCESSORY CONTROL BOX (P/N 12268582) - CONTINUED

b. Assembly.

NOTE

All cushions are installed in the same manner. A ground lead is attached to one of the cushions.

- 1 Install three cushions (113) on accessory control box body (7) with six new rivets (111).
- 2 Install ground lead (112) and cushion (113) on accessory control box body (7) with two new rivets (111).
- 3 Install four lead assemblies (36, 108, 109, and 110) in accessory control box body (7) with 16 screws (104), 16 flat washers (107), 16 new lockwashers (106) and 16 nuts (105).

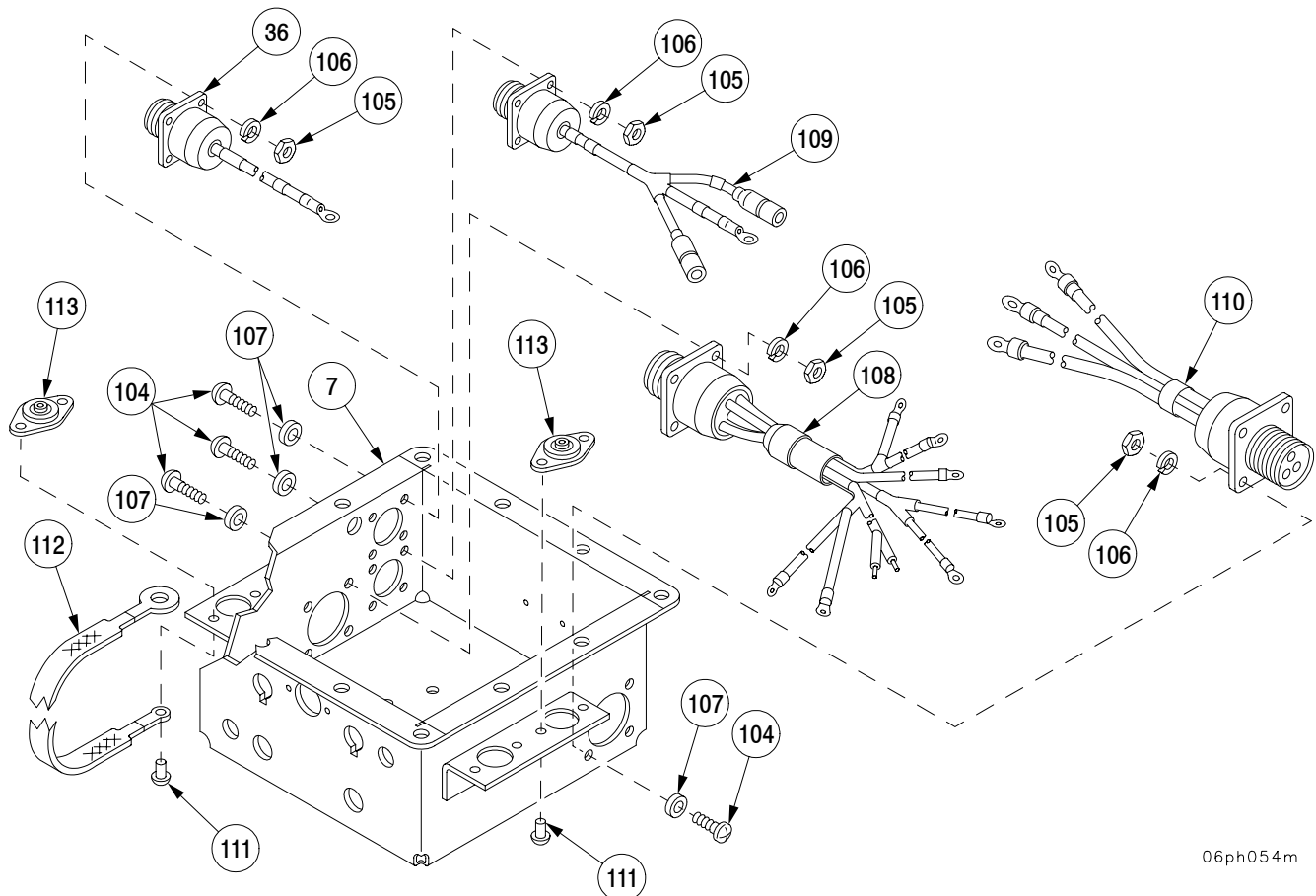

06ph054m

Section II. INSTRUMENT OR ENGINE CONTROL PANELS - CONTINUED

7-5 ACCESSORY CONTROL BOX (P/N 12268582) - CONTINUED

b. Assembly - Continued

NOTE

Apply a thorough coat of anti-corrosion silicone compound to socket before installing new lamp.

- 4 Install lamp assembly (64) in accessory control box body (7) with two new lockwashers (103) and two screws (102).
- 5 Install two panel light brackets (90) in accessory control box body (7) with two new lockwashers (101) and two nuts (100).
- 6 Install two indicator lamp bases (93) and front panel (99) in accessory control box body (7) with two lockwashers (98) and two nuts (97).
- 7 Install two lamps (96) and two indicator lens caps (95) on two indicator lamp bases (93).

NOTE

Refer to electrical schematic foldouts for internal accessory control box wiring.

To install electrical connector on lamp assembly, solder point of connection.

- 8 Install insulation (94) on leads (46, 47, 62, 91 and 92).
- 9 Solder leads (46, 47, 91, and 92) and two leads (62) on two indicator lamp bases (93).
- 10 Install lead (89) on two panel light brackets (90) with two screws (87) and two new lockwashers (88).
- 11 Install two lamps (86) and two panel light lens caps (85).
- 12 Install leads (9, 78, 79, 80, 81, and 82) on HEAT SELECTOR switch (77) with five screws (83) and five lockwashers (84).
- 13 Install HEAT SELECTOR switch (77) in accessory control box body (7) with lockwasher (69) and nut (68).
- 14 Install leads (11, 29, 46, 63, 71, 72, and 73) and jumper lead (74) on fan switch (70) with six screws (75) and six lockwashers (76).
- 15 Install switch (70) in accessory control box body (7) with lockwasher (69) and nut (68).
- 16 Install lamp (67), gasket (66) and lens (65) on lamp assembly (64).
- 17 Install lead (63) on lamp assembly (64).

Section II. INSTRUMENT OR ENGINE CONTROL PANELS - CONTINUED

7-5 ACCESSORY CONTROL BOX (P/N 12268582) - CONTINUED

b. Assembly - Continued

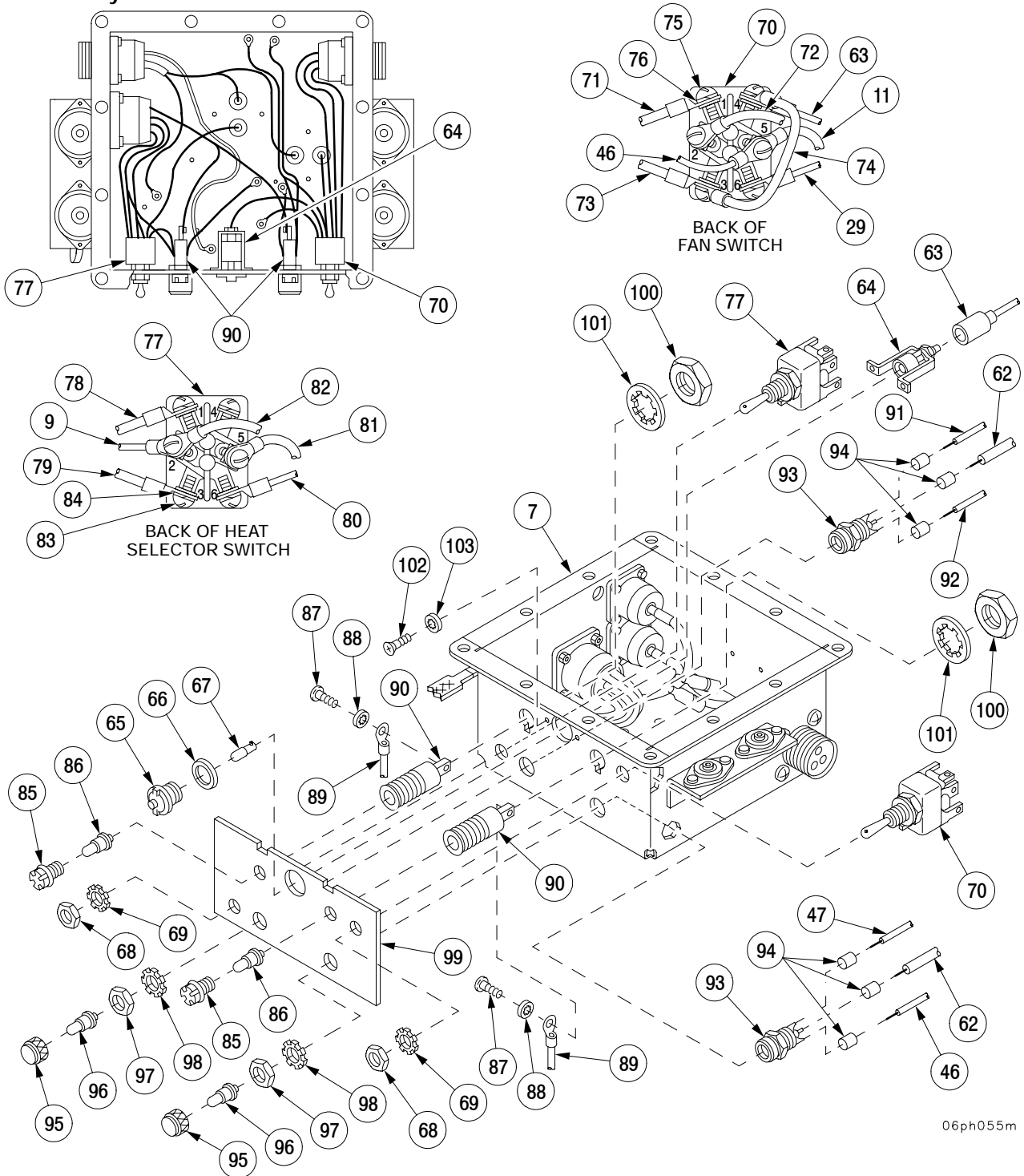

Section II. INSTRUMENT OR ENGINE CONTROL PANELS - CONTINUED

7-5 ACCESSORY CONTROL BOX (P/N 12268582) - CONTINUED

b. Assembly - Continued

- 18 Install two ground leads (62) and ground lead (31) to accessory control box body (7) with screw (59), two new lockwashers (60), and two nuts (61).
- 19 Install fitting (56) with nut (58), and fitting (57) in accessory control box body (7).
- 20 Install two tubes (49 and 50) to two fittings (56 and 57) and secure two tubes (49 and 50) with two new straps (55).
- 21 Install pressure switch (48) in accessory control box body (7) with two screws (51), two flat washers (54), two new lockwashers (53), and two nuts (52).
- 22 Install two tubes (49 and 50) to pressure switch (48).
- 23 Install two leads (46 and 47) to pressure switch (48) with two screws (42), two flat washers (45), two new lockwashers (44), and two nuts (43).
- 24 Perform adjustment on pressure switch (48).
- 25 Install relay (30) in accessory control box body (7) with two screws (38), two flat washers (41), two new lockwashers (40), and two nuts (39).
- 26 Install lead (37) on terminal A2 of relay (30) with flat washer (34), new lockwasher (33), and nut (32).
- 27 Install lead (35) on terminal B1 of relay (30) with flat washer (34), new lockwasher (33), and nut (32).
- 28 Install two leads (36 and 37) on terminal B2 of relay (30) with flat washer (34), new lockwasher (33), and nut (32).
- 29 Install two leads (19 and 35) on terminal A1 of relay (30) with flat washer (34), new lockwasher (33), and nut (32).
- 30 Install ground lead (31) on terminal X2 of relay (30) with flat washer (28), new lockwasher (27), and nut (26).
- 31 Install lead (29) on terminal X1 of relay (30) with flat washer (28), new lockwasher (27), and nut (26).

Section II. INSTRUMENT OR ENGINE CONTROL PANELS - CONTINUED

7-5 ACCESSORY CONTROL BOX (P/N 12268582) - CONTINUED

b. Assembly - Continued

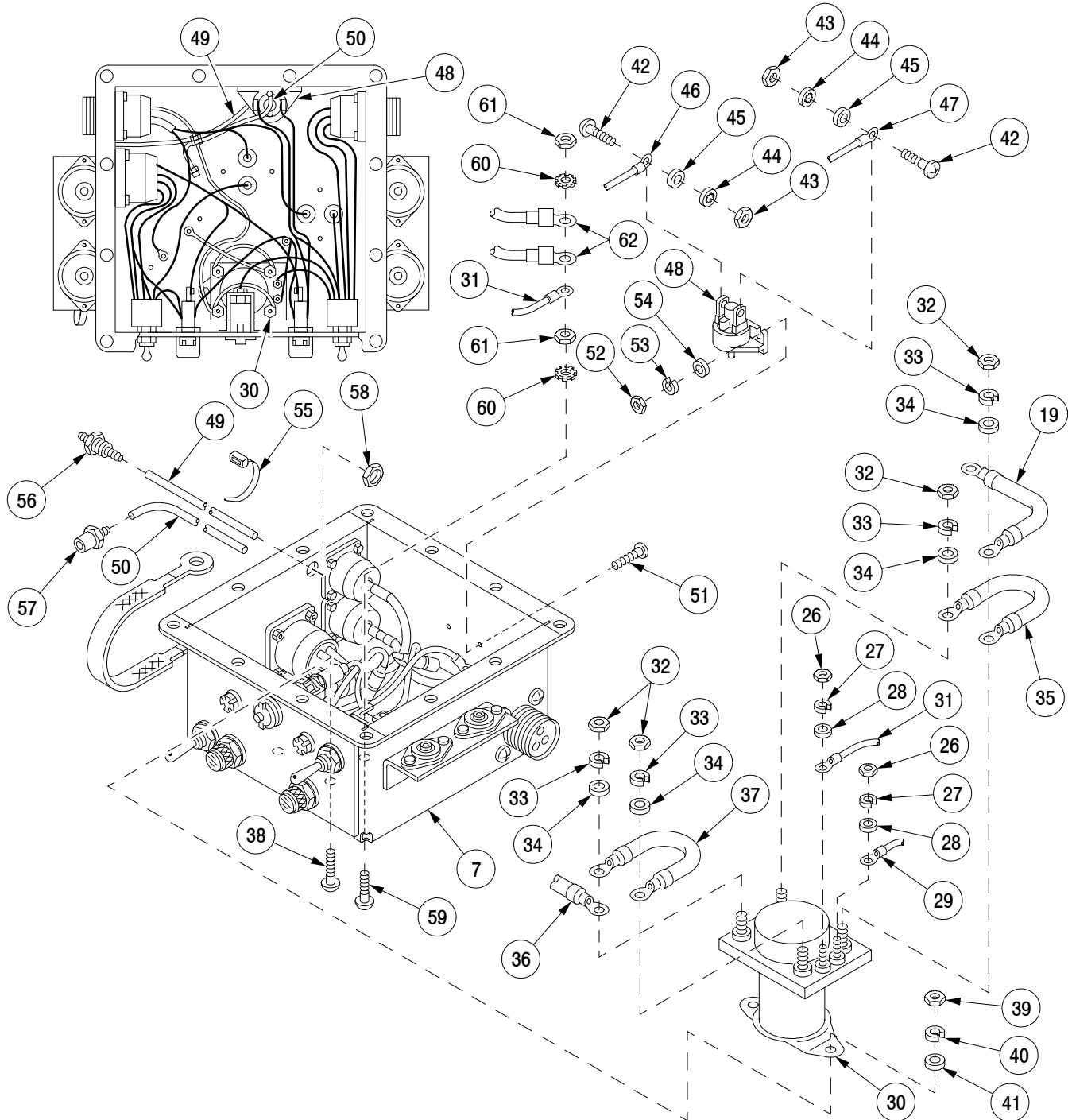

06ph056m

Section II. INSTRUMENT OR ENGINE CONTROL PANELS - CONTINUED

7-5 ACCESSORY CONTROL BOX (P/N 12268582) - CONTINUED

b. Assembly - Continued

- 32 Install circuit breaker (21) in accessory control box body (7) with two screws (22), two flat washers (25), two new lockwashers (24), and two nuts (23).
- 33 Install two leads (19 and 20) on circuit breaker (21) with four new lockwashers (18) and two screws (17).
- 34 Install two circuit breakers (12) in accessory control box body (7) with four screws (13), four flat washers (16), four new lockwashers (15), and four nuts (14).
- 35 Install four electrical leads (8, 9, 10, and 11) to two circuit breakers (12).

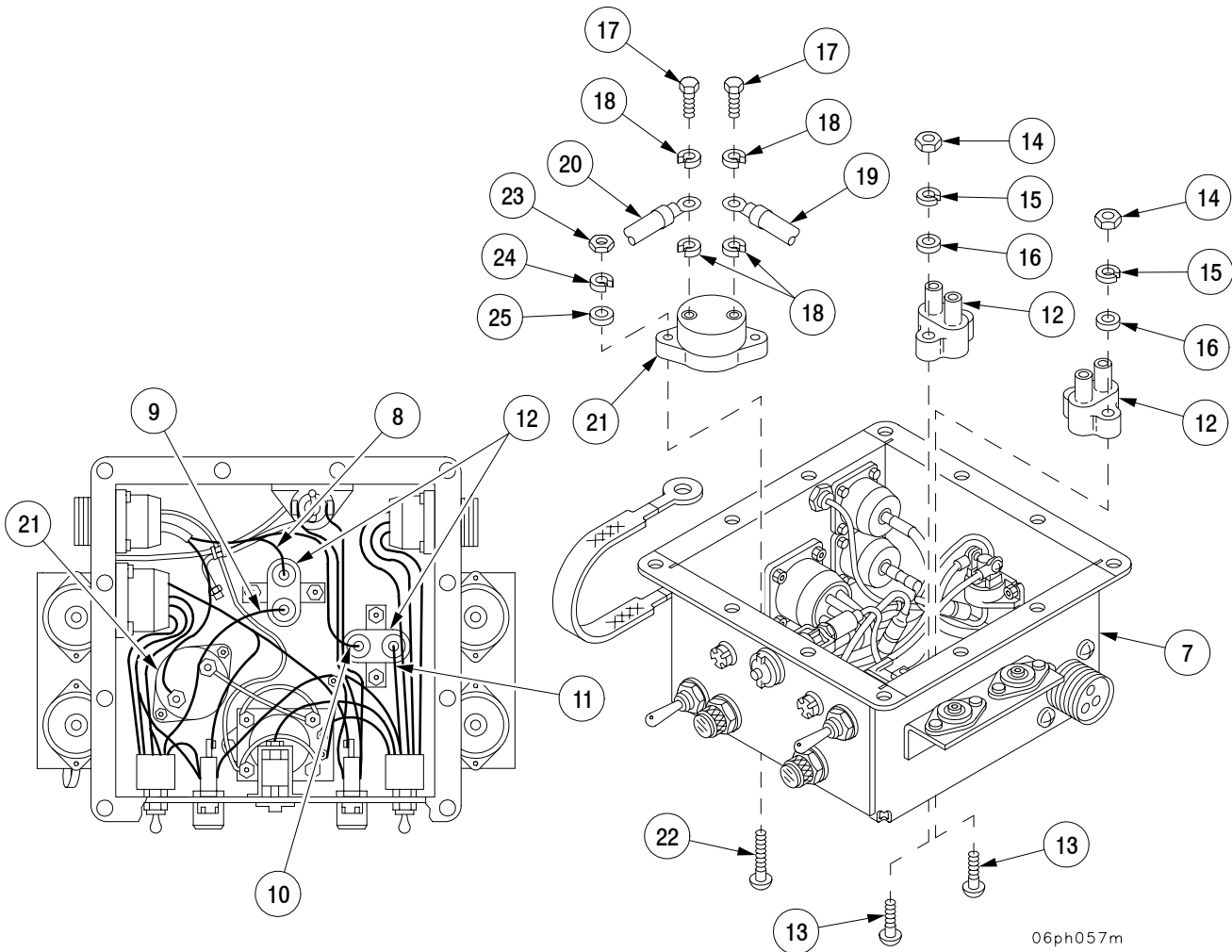

Section II. INSTRUMENT OR ENGINE CONTROL PANELS - CONTINUED

7-5 ACCESSORY CONTROL BOX (P/N 12268582) - CONTINUED

b. Assembly - Continued

CAUTION

Prior to installing cover on accessory control box, make sure wiring connections are correct. Failure to make correct connection may result in equipment damage.

- 36 Install cover (5) on accessory control box body (7) with new gasket (6), 12 screws (1), 12 flat washers (4), 12 new lockwashers (3), and 12 nuts (2).

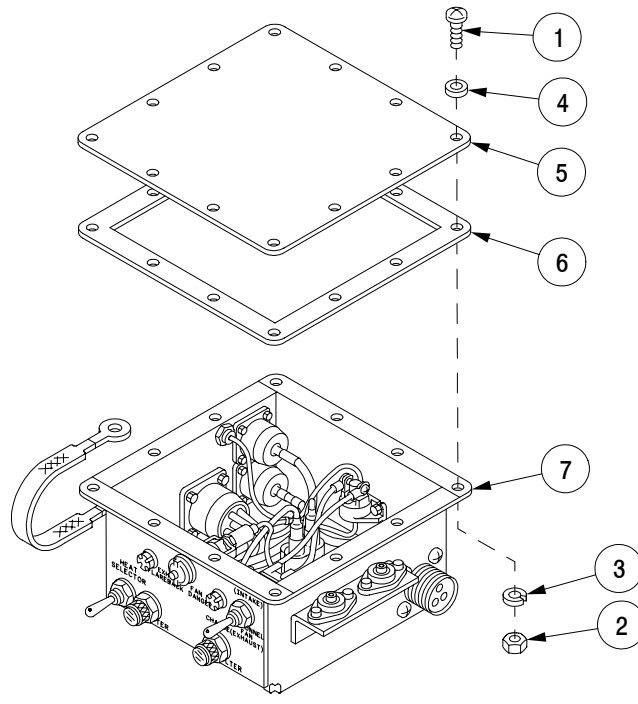

06ph058m

NOTE

FOLLOW-ON MAINTENANCE:
 Install accessory control box
 (TM 9-2350-314-20-1-2)

Section II. INSTRUMENT OR ENGINE CONTROL PANELS - CONTINUED

7-5A ACCESSORY CONTROL BOX (P/N 12268547).

This task covers: a. Disassembly b. Assembly

INITIAL SETUP

Tools

Fuel and electrical tool kit
(SC 5180-95-B08)
Soldering gun (item 49, Appx F)
Hand riveter (item 37, Appx F)
Tubing (item 52, Appx F)
Purging kit (item 28, Appx F)
Insulation (item 60, Appx F)

Equipment Conditions

Accessory control box removed
(TM 9-2350-314-20-1-2)

References

TM 9-2350-314-20-1-2

Materials/Parts

Lockwashers (16) (item 72, Appx E)
Lockwashers (12) (item 77, Appx E)
Gasket (item 4, Appx E)
Lockwashers (2) (item 58, Appx E)
Tiedown straps (2) (item 56, Appx E)
Lockwashers (2) (item 69, Appx E)
Lockwashers (2) (item 64, Appx E)
Lockwashers (2) (item 59, Appx E)
Lockwashers (4) (item 73, Appx E)
Lockwashers (8) (item 76, Appx E)
Rivets (8) (item 47, Appx E)
Lockwashers (2) (item 82, Appx E)
Lockwashers (4) (item 67, Appx E)
Lockwasher (item 36, Appx E)
Lockwasher (item 39, Appx E)
Solder (item 28, Appx B)
Soldering flux (item 10, Appx B)
Distilled water (item 32, Appx B)
Silicone compound (item 34, Appx B)

NOTE

- The procedures in this task are for vehicles with Accessory Control Box P/N 12268547.
- See para 7-5 for the task that covers the procedures for vehicles with Accessory Control Box P/N 12268582.

a. Disassembly.

- 1 Remove 12 screws (1), 12 nuts (2), 12 lockwashers (3), 12 flat washers (4), cover (5), and gasket (6) from accessory control box body (7). Discard gasket and lockwashers.

Section II. INSTRUMENT OR ENGINE CONTROL PANELS - CONTINUED

7-5A ACCESSORY CONTROL BOX (P/N 12268547) - CONTINUED

a. Disassembly - Continued

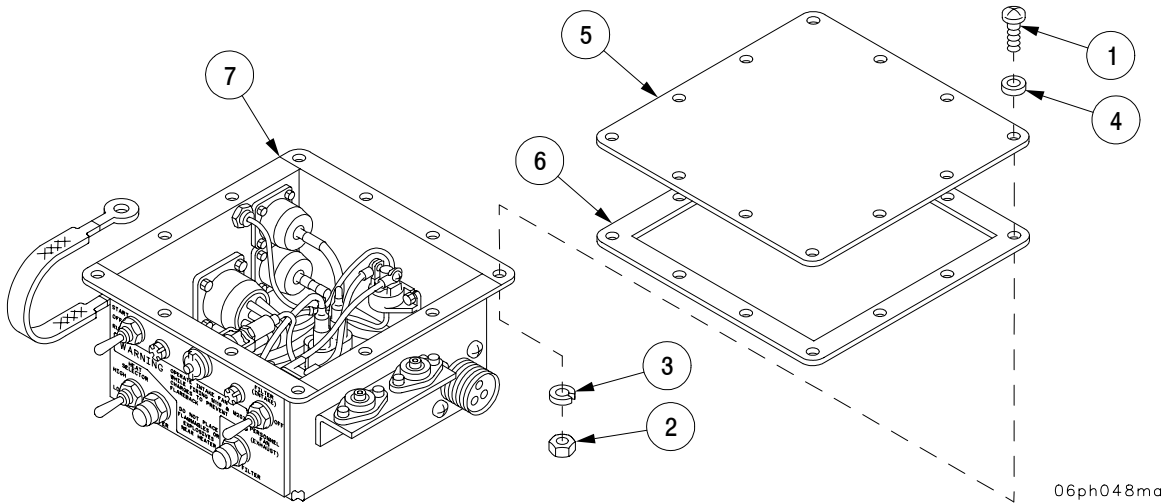

NOTE

- Refer to electrical schematic foldouts for internal accessory control box wiring.
- Tag all electrical connections and electrical leads prior to removal to aid in installation.

2 Remove four electrical leads (8, 9, 10, and 11) from two circuit breakers (12).

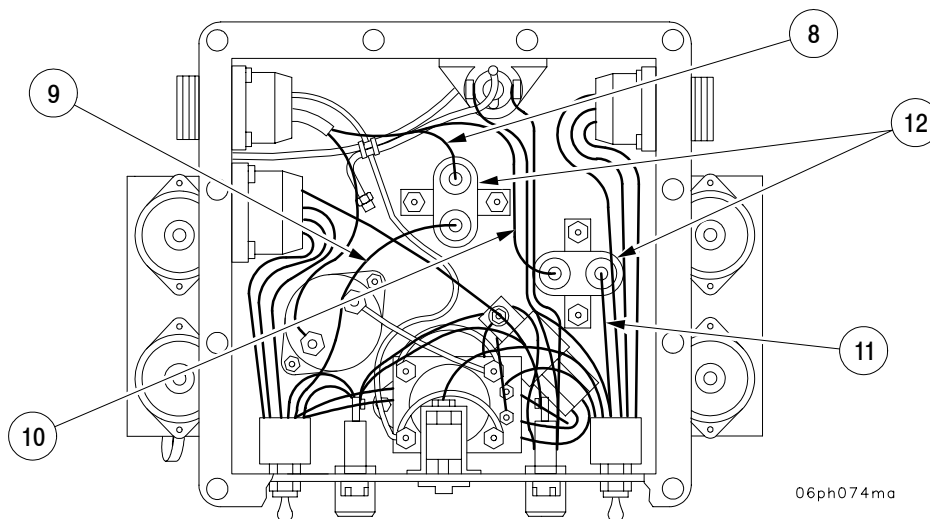

Section II. INSTRUMENT OR ENGINE CONTROL PANELS - CONTINUED

7-5A ACCESSORY CONTROL BOX (P/N 12268547) - CONTINUED

a. Disassembly - Continued

- 3 Remove four screws (13), four nuts (14), four lockwashers (15), four flat washers (16), and two circuit breakers (12) from accessory control box body (7). Discard lockwashers.
- 4 Remove two screws (17), four lockwashers (18), and two leads (19 and 20) from circuit breaker (21). Discard lockwashers.
- 5 Remove two screws (22), two nuts (23), two lockwashers (24), two flat washers (25), and circuit breaker (21) from accessory control box body (7). Discard lockwashers.

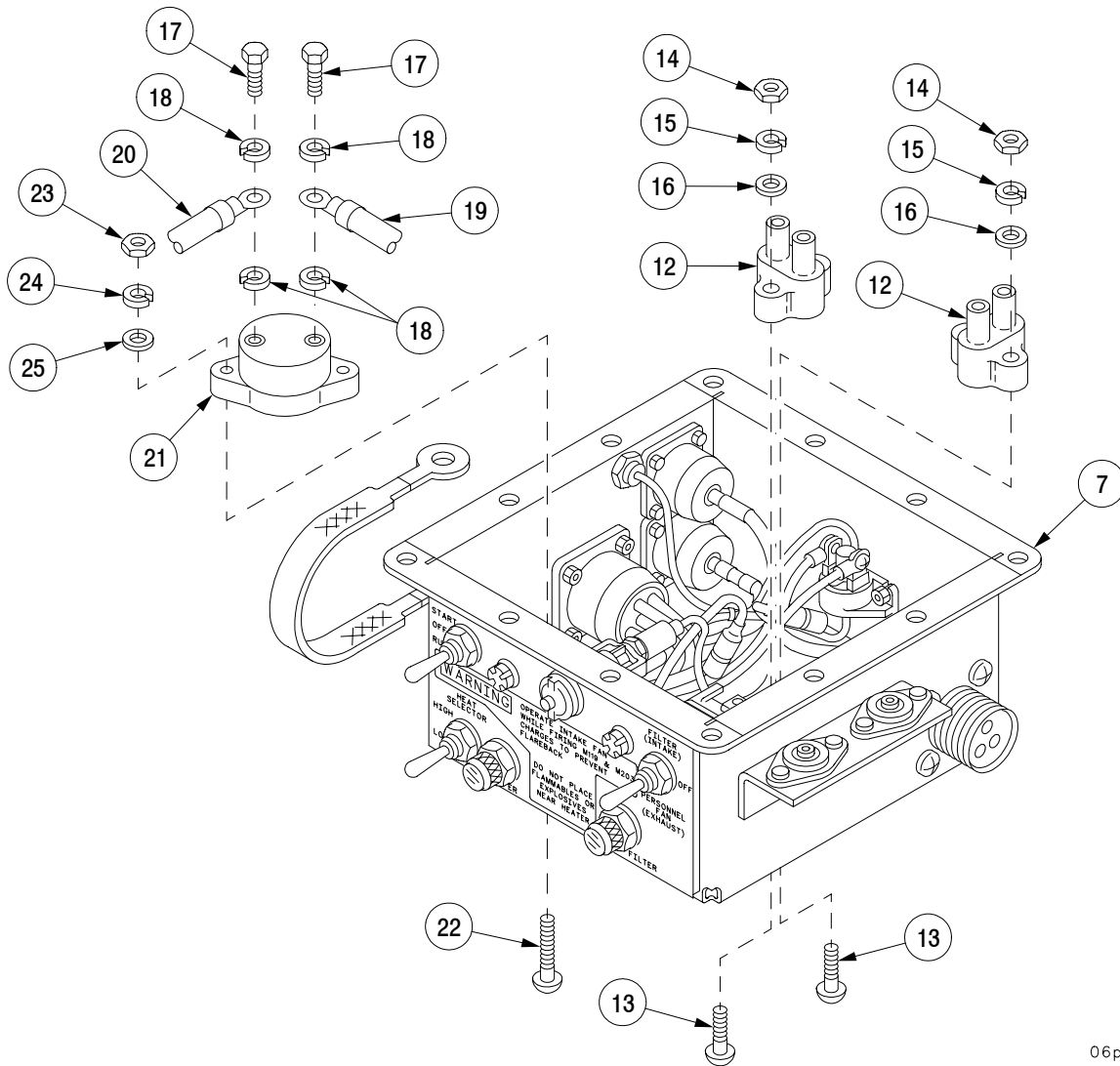

06ph049ma

Section II. INSTRUMENT OR ENGINE CONTROL PANELS - CONTINUED

7-5A ACCESSORY CONTROL BOX (P/N 12268547) - CONTINUED

a. Disassembly - Continued

- 6 Remove nut (26), lockwasher (27), flat washer (28), and lead (29) from terminal X1 of relay (30). Discard lockwasher.
- 7 Remove nut (26), lockwasher (27), flat washer (28), and ground lead (31) from terminal X2 of relay (30). Discard lockwasher.
- 8 Remove nut (32), lockwasher (33), flat washer (34), and two leads (19 and 35) from terminal A1 of relay (30). Discard lockwasher.
- 9 Remove lead (19) from accessory control box body (7).
- 10 Remove nut (32), lockwasher (33), flat washer (34), and two leads (36 and 37) from terminal B2 of relay (30). Discard lockwasher.
- 11 Remove nut (32), lockwasher (33), flat washer (34), and lead (35) from terminal B1 of relay (30). Discard lockwasher.
- 12 Remove lead (35) from accessory control box body (7).
- 13 Remove nut (32), lockwasher (33), flat washer (34), and lead (37) from terminal A2 of relay (30). Discard lockwasher.
- 14 Remove lead (37) from accessory control box body (7).
- 15 Remove two screws (38), two nuts (39), two lockwashers (40), two flat washers (41), and relay (30) from accessory control box body (7). Discard lockwashers.

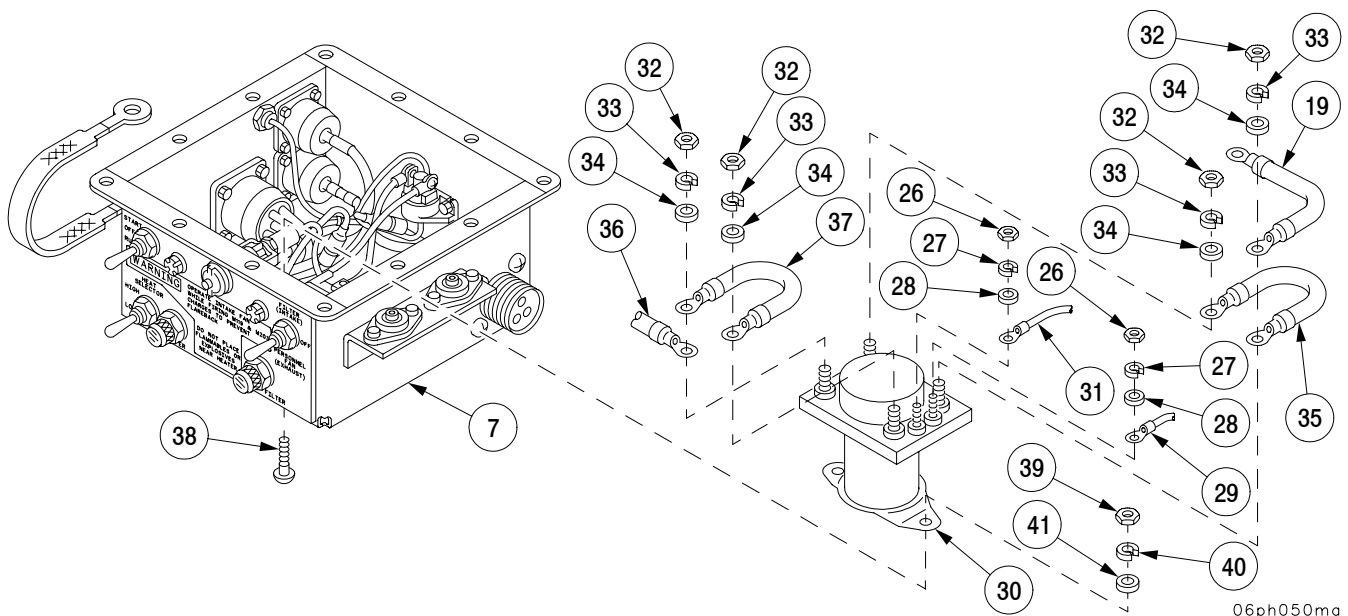

Section II. INSTRUMENT OR ENGINE CONTROL PANELS - CONTINUED

7-5A ACCESSORY CONTROL BOX (P/N 12268547) - CONTINUED

a. Disassembly - Continued

- 16 Remove two screws (42), two nuts (43), two lockwashers (44), two flat washers (45), and two leads (46 and 47) from pressure switch (48). Discard lockwashers.
- 17 Remove two tubes (49 and 50) from pressure switch (48).
- 18 Remove two screws (51), two nuts (52), two lockwashers (53), two flat washers (54), and pressure switch (48) from accessory control box body (7). Discard lockwashers.
- 19 Remove two straps (55) and two tubes (49 and 50) from two fittings (56 and 57). Discard straps.
- 20 Remove nut (58) from fitting (56) and remove fittings (56 and 57) from accessory control box body (7).
- 21 Unplug connector (59) from relay (60).
- 22 Remove screw (61), two lockwashers (62), and two nuts (63) securing ground lead (31), three ground leads (64), and relay (60) to accessory control box body (7). Discard lockwashers.
- 23 Remove ground lead (31) from accessory control box body (7).

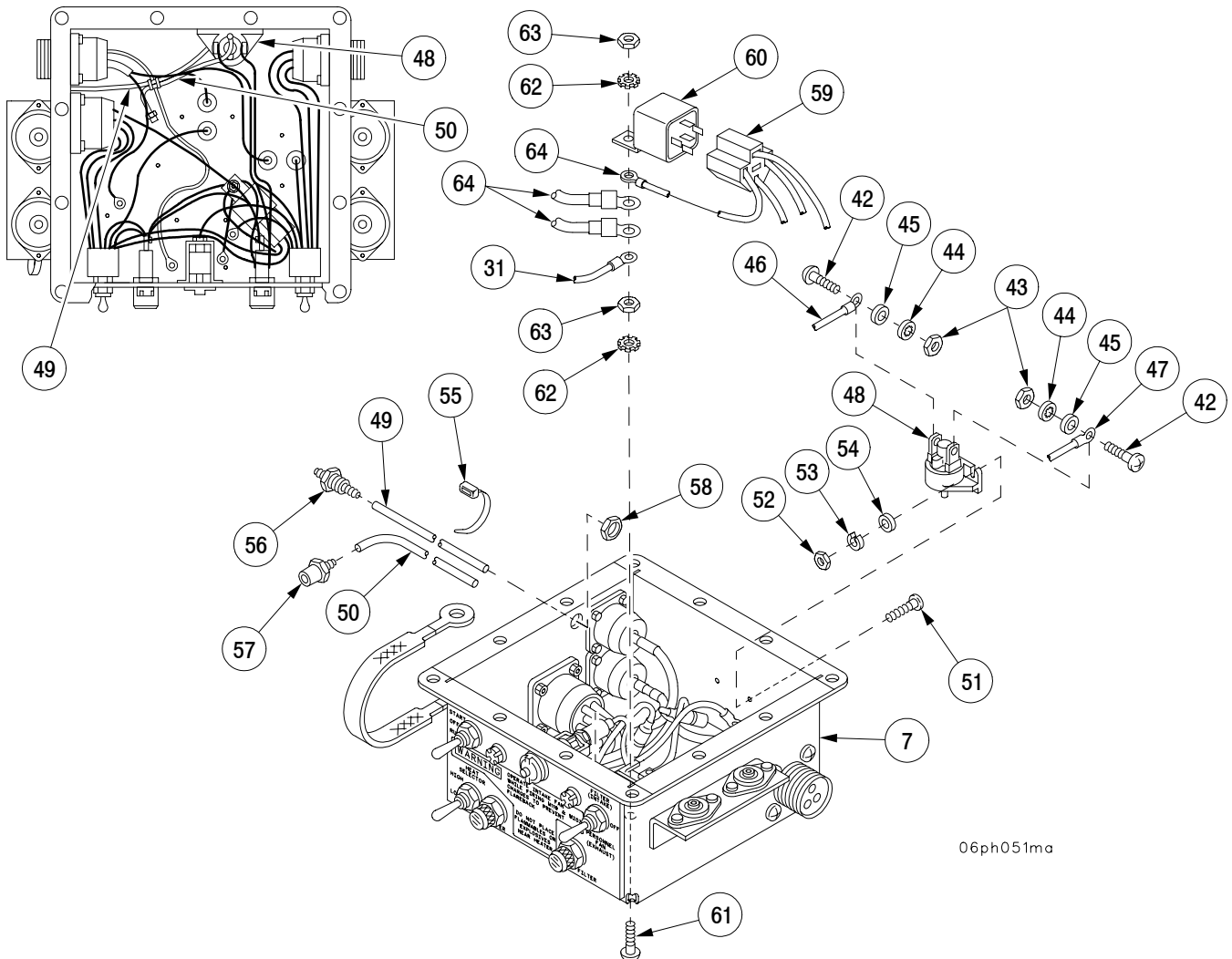

06ph051ma

Section II. INSTRUMENT OR ENGINE CONTROL PANELS - CONTINUED

7-5A ACCESSORY CONTROL BOX (P/N 12268547) - CONTINUED

a. Disassembly - Continued

- 24 Remove lead (65) from lamp assembly (66).
- 25 Remove lens cap (67), gasket (68), and lamp (69) from lamp assembly (66).
- 26 Remove nut (70), lockwasher (71), and switch (72) from accessory control box body (7).
- 27 Remove leads (11, 29, 46, 65, 73, 74, and 75) and jumper lead (76) from fan switch (72) by removing six screws (77) and six lockwashers (78).
- 28 Remove nut (70), lockwasher (71), and switch (79) from accessory control box body (7).
- 29 Remove leads (80 and 81) from HEAT SELECTOR switch (79), by removing two screws (82) and two lockwashers (83).
- 30 Remove nut (70), lockwasher (71), and HEATER control switch (84) from accessory control box body (7).
- 31 Remove leads (9, 85, 86, and 87) from HEATER control switch (84) by removing three screws (88) and three lockwashers (89).
- 32 Remove lead (9) from accessory control box body (7).

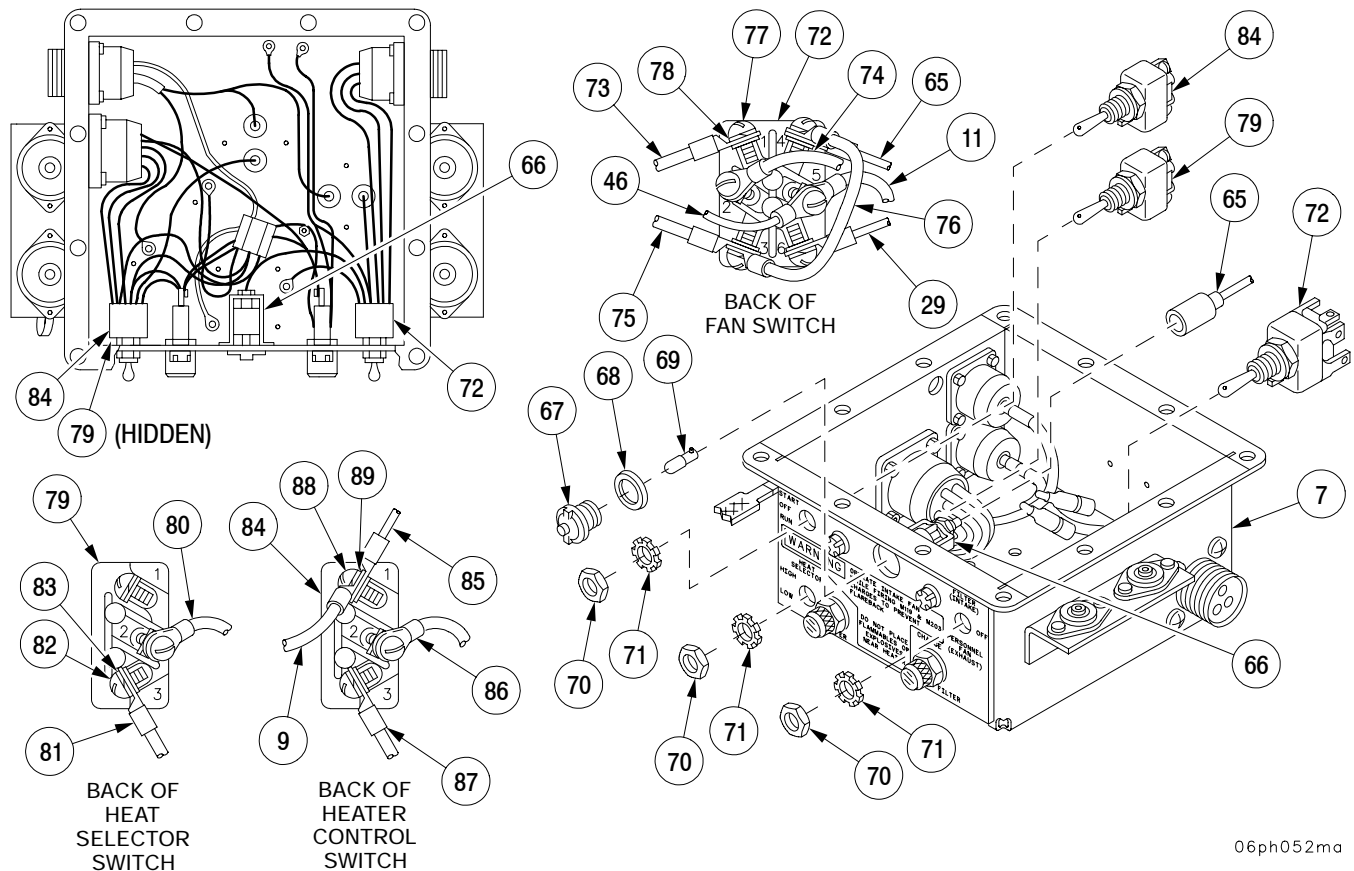

06ph052ma

Section II. INSTRUMENT OR ENGINE CONTROL PANELS - CONTINUED

7-5A ACCESSORY CONTROL BOX (P/N 12268547) - CONTINUED

a. Disassembly - Continued

- 33 Remove two panel light lens caps (90) with seals and two lamps (91), two screws (92), two lockwashers (93) and lead (94) from two panel light brackets (95).

NOTE

To remove electrical connector from lamp assembly, unsolder points of connection.

- 34 Unsolder leads (46, 47, 64, 96 and 97) from two indicator lamp bases (98).
- 35 Remove insulation (99) from leads (46, 47, 64, 96 and 97).
- 36 Remove leads (46 and 47) and two leads (64) from accessory control box body (7).
- 37 Remove two indicator lens caps (100), two lamps (101), two nuts (102), two lockwashers (103), two indicator lamp bases (98) and front panel (104) from accessory control box body (7).
- 38 Remove two nuts (105), two lockwashers (106) and two panel light brackets (95) from accessory control box body (7). Discard lockwashers.
- 39 Remove two screws (107), two lockwashers (108) and lamp assembly (66) from accessory control box body (7). Discard lockwashers.

Section II. INSTRUMENT OR ENGINE CONTROL PANELS - CONTINUED

7-5A ACCESSORY CONTROL BOX (P/N 12268547) - CONTINUED

a. Disassembly - Continued

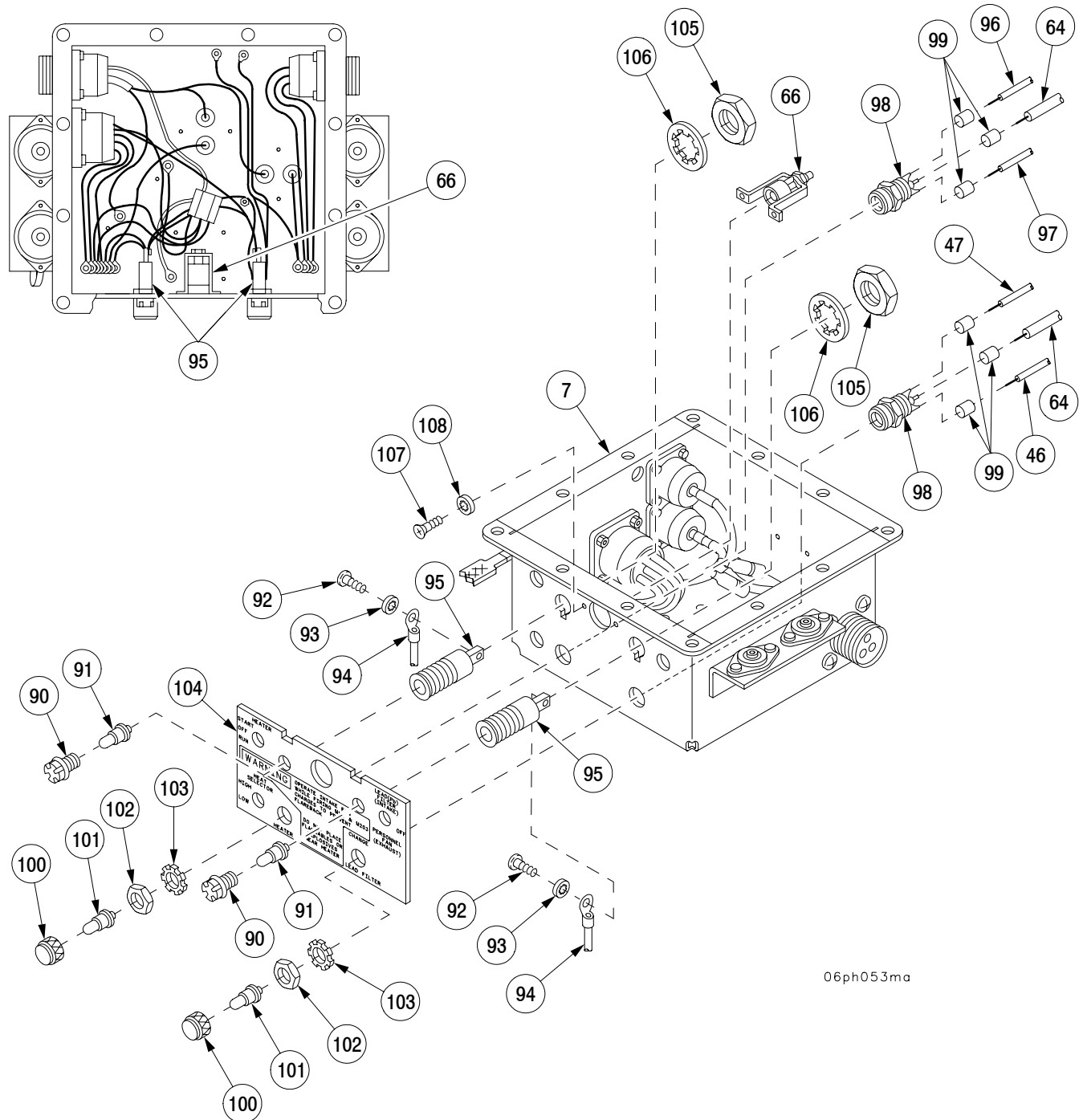

Section II. INSTRUMENT OR ENGINE CONTROL PANELS - CONTINUED

7-5A ACCESSORY CONTROL BOX (P/N 12268547) - CONTINUED

a. Disassembly - Continued

- 40 Remove 16 screws (109), 16 nuts (110), 16 lockwashers (111), 16 flat washers (112), three lead assemblies (36, 113, and 114), and wiring harness (115) from accessory control box body (7). Discard lockwashers.

NOTE

There are four cushions used on accessory control box. All cushions are removed in the same manner. A ground lead is attached to a cushion. Note location to aid in installation of ground lead.

- 41 Remove two rivets (116), ground lead (117), and cushion (118) from accessory control box body (7). Discard rivets.
- 42 Remove six rivets (116) and three cushions (118) from accessory control box body (7). Discard rivets.

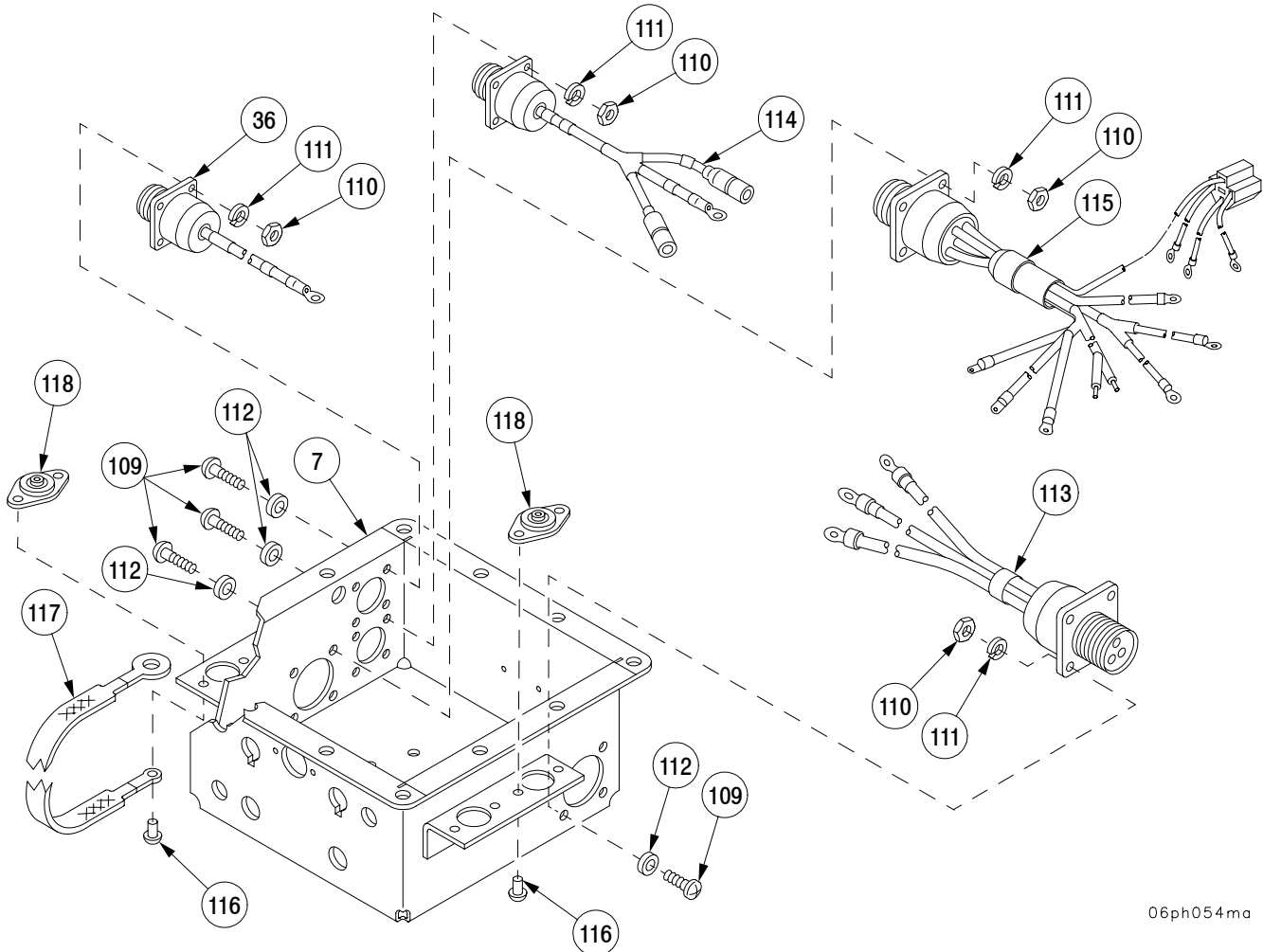

06ph054ma

Section II. INSTRUMENT OR ENGINE CONTROL PANELS - CONTINUED

7-5A ACCESSORY CONTROL BOX (P/N 12268547) - CONTINUED

b. Assembly.

NOTE

All cushions are installed in the same manner. A ground lead is attached to one of the cushions.

- 1 Install three cushions (118) on accessory control box body (7) with six new rivets (116).
- 2 Install ground lead (117) and cushion (118) on accessory control box body (7) with two new rivets (116).
- 3 Install three lead assemblies (36, 113, and 114), and wiring harness (115) in accessory control box body (7) with 16 screws (109), 16 flat washers (112), 16 new lockwashers (111) and 16 nuts (110).

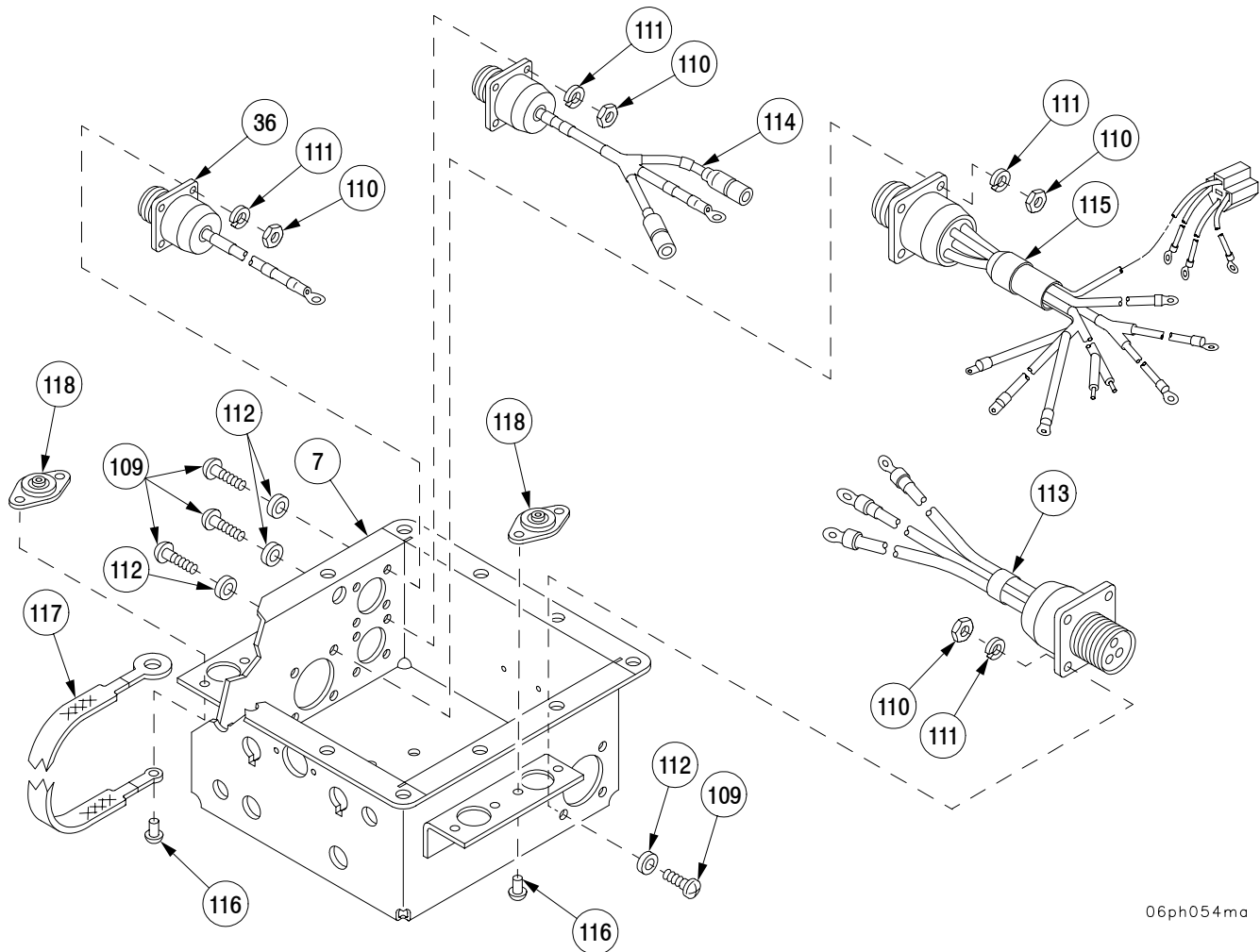

Section II. INSTRUMENT OR ENGINE CONTROL PANELS - CONTINUED

7-5A ACCESSORY CONTROL BOX (P/N 12268547) - CONTINUED

b. Assembly - Continued

NOTE

Apply a thorough coat of anti-corrosion silicone compound to socket before installing new lamp.

- 4 Install lamp assembly (66) in accessory control box body (7) with two new lockwashers (108) and two screws (107).
- 5 Install two panel light brackets (95) in accessory control box body (7) with two new lockwashers (106) and two nuts (105).
- 6 Install two indicator lamp bases (98) and front panel (104) in accessory control box body (7) with two lockwashers (103) and two nuts (102).
- 7 Install two lamps (101) and two indicator lens caps (100) on two indicator lamp bases (98).

NOTE

- Refer to electrical schematic foldouts for internal accessory control box wiring.
 - To install electrical connector on lamp assembly, solder point of connection.
- 8 Install insulation (99) on leads (46, 47, 64, 96, and 97).
 - 9 Solder leads (46, 47, 96, and 97) and two leads (64) on two indicator lamp bases (98).
 - 10 Install lead (94) on two panel light brackets (95) with two screws (92) and two new lockwashers (93).
 - 11 Install two lamps (91) and two panel light lens caps (90).
 - 12 Install leads (9, 85, 86, and 87) on HEATER control switch (84) with three screws (88) and three lockwashers (89).
 - 13 Install HEATER control switch (84) in accessory control box (7) with lockwasher (71) and nut (70).
 - 14 Install leads (80 and 81) on HEAT SELECTOR switch (79) with two screws (82) and two lockwashers (83).
 - 15 Install HEATER SELECTOR switch (79) in accessory control box (7) with lockwasher (71) and nut (70).
 - 16 Install leads (11, 29, 46, 65, 73, 74, and 75) and jumper lead (76) on fan switch (72) with six screws (77) and six lockwashers (78).
 - 17 Install switch (72) in accessory control box body (7) with lockwasher (71) and nut (70).
 - 18 Install lamp (69), gasket (68), and lens (67) on lamp assembly (66).
 - 19 Install lead (65) on lamp assembly (66).

Section II. INSTRUMENT OR ENGINE CONTROL PANELS - CONTINUED

7-5A ACCESSORY CONTROL BOX (P/N 12268547) - CONTINUED

b. Assembly - Continued

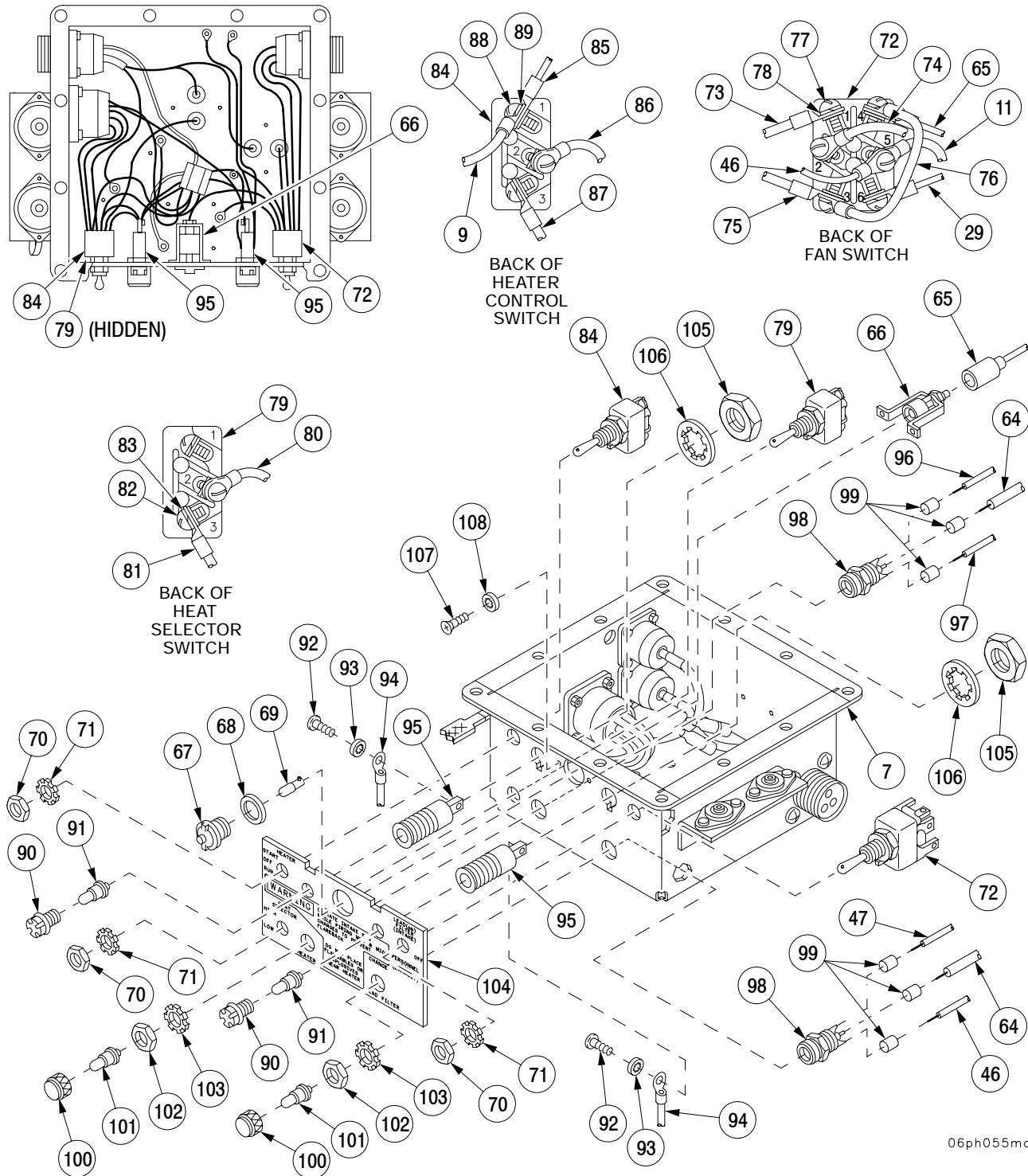

06ph055ma

Section II. INSTRUMENT OR ENGINE CONTROL PANELS - CONTINUED

7-5A ACCESSORY CONTROL BOX (P/N 12268547) - CONTINUED

b. Assembly - Continued

- 20 Install three ground leads (64), relay (60), and ground lead (31) to accessory control box body (7) with screw (61), two new lockwashers (62), and two nuts (63).
- 21 Plug connector (59) into relay (60).
- 22 Install fitting (56) with nut (58), and fitting (57) in accessory control box body (7).
- 23 Install two tubes (49 and 50) to two fittings (56 and 57) and secure two tubes (49 and 50) with two new straps (55).
- 24 Install pressure switch (48) in accessory control box body (7) with two screws (51), two flat washers (54), two new lockwashers (53), and two nuts (52).
- 25 Install two tubes (49 and 50) to pressure switch (48).
- 26 Install two leads (46 and 47) to pressure switch (48) with two screws (42), two flat washers (45), two new lockwashers (44), and two nuts (43).
- 27 Perform adjustment on pressure switch (48).
- 28 Install relay (30) in accessory control box body (7) with two screws (38), two flat washers (41), two new lockwashers (40), and two nuts (39).
- 29 Install lead (37) on terminal A2 of relay (30) with flat washer (34), new lockwasher (33), and nut (32).
- 30 Install lead (35) on terminal B1 of relay (30) with flat washer (34), new lockwasher (33), and nut (32).
- 31 Install two leads (36 and 37) on terminal B2 of relay (30) with flat washer (34), new lockwasher (33), and nut (32).
- 32 Install two leads (19 and 35) on terminal A1 of relay (30) with flat washer (34), new lockwasher (33), and nut (32).
- 33 Install ground lead (31) on terminal X2 of relay (30) with flat washer (28), new lockwasher (27), and nut (26).
- 34 Install lead (29) on terminal X1 of relay (30) with flat washer (28), new lockwasher (27), and nut (26).

Section II. INSTRUMENT OR ENGINE CONTROL PANELS - CONTINUED

7-5A ACCESSORY CONTROL BOX (P/N 12268547) - CONTINUED

b. Assembly - Continued

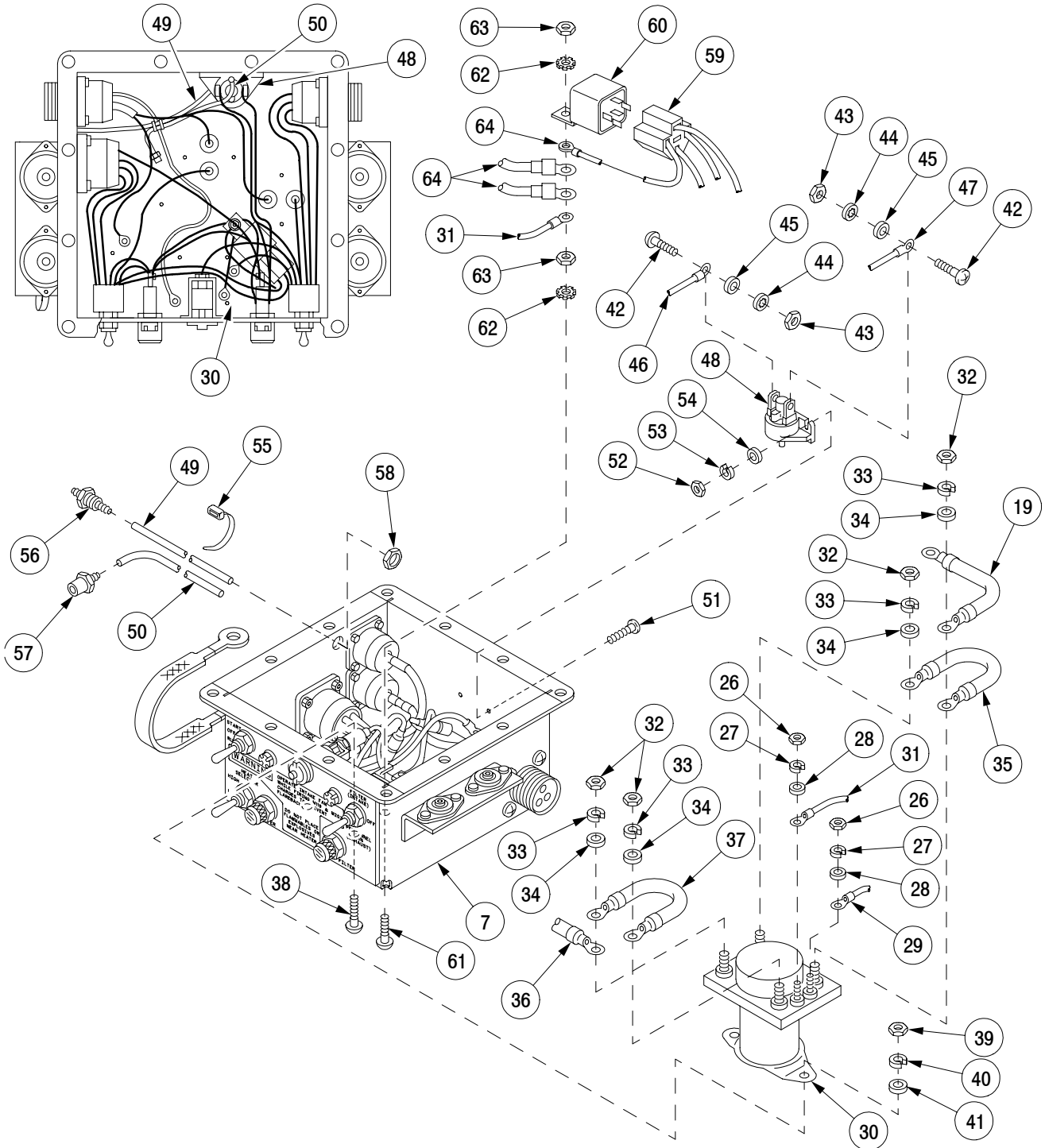

06ph056ma

Section II. INSTRUMENT OR ENGINE CONTROL PANELS - CONTINUED

7-5A ACCESSORY CONTROL BOX (P/N 12268547) - CONTINUED

b. Assembly - Continued

- 35 Install circuit breaker (21) in accessory control box body (7) with two screws (22), two flat washers (25), two new lockwashers (24), and two nuts (23).
- 36 Install two leads (19 and 20) on circuit breaker (21) with four new lockwashers (18) and two screws (17).
- 37 Install two circuit breakers (12) in accessory control box body (7) with four screws (13), four flat washers (16), four new lockwashers (15), and four nuts (14).
- 38 Install four electrical leads (8, 9, 10, and 11) to two circuit breakers (12).

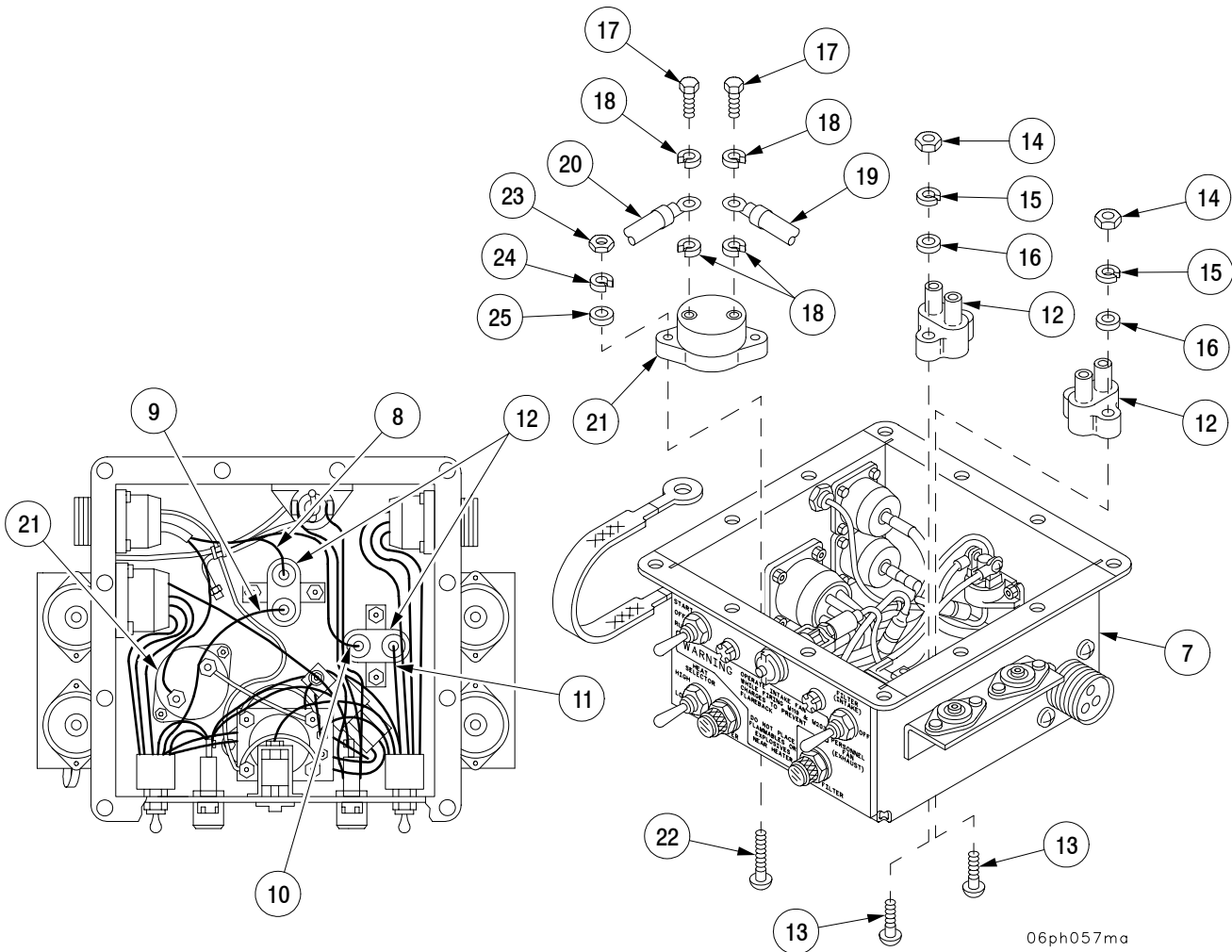

Section II. INSTRUMENT OR ENGINE CONTROL PANELS - CONTINUED

7-5A ACCESSORY CONTROL BOX (P/N 12268547) - CONTINUED

b. Assembly - Continued

CAUTION

Prior to installing cover on accessory control box, make sure wiring connections are correct. Failure to make correct connection may result in equipment damage.

- 39 Install cover (5) on accessory control box body (7) with new gasket (6), 12 screws (1), 12 flat washers (4), 12 new lockwashers (3), and 12 nuts (2).

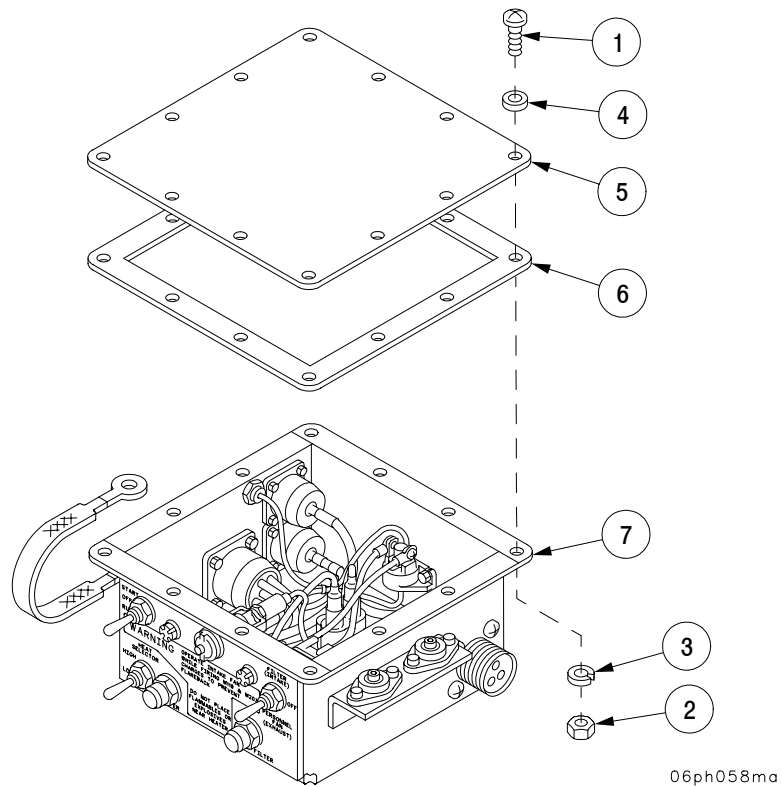

NOTE

FOLLOW-ON MAINTENANCE:
 Install accessory control box
 (TM 9-2350-314-20-1-2)

Section III. HULL WIRING HARNESS

7-6 WIRING HARNESS AND CABLE REPAIR.

This task covers: a. Disassembly b. Assembly

INITIAL SETUP

Tools

Fuel and electrical tool kit (SC 5180-95-B08)
Electrical contact tool kit (item 51, Appx F)
Electrical heat gun (item 24, Appx F)
Soldering gun (item 49, Appx F)
Multimeter (item 31, Appx F)
Terminal repair kit (item 26, Appx F)
Tubing (item 52, Appx F)

References

TB SIG 222

Materials/Parts

Insulation tape (item 30, Appx B)
Solder (item 28, Appx B)
Soldering flux (item 10, Appx B)
Adhesive (item 3, Appx B)
Adhesive (item 3.1, Appx B)
Adhesive (item 27.1, Appx B)

NOTE

- When removing more than one wire from a multiple wire receptacle, record which wire was removed from which pin hole.
- Before proceeding, see detailed instructions on soldering and solder (TB SIG 222).
- Cable identifiers are attached to cables. These tags are embossed with the cable identification number. Cable identifier numbers are shown on the systems wiring diagram.
- Wire identifiers are embossed with the same individual wire number. Wire identifier numbers are also shown on systems wiring diagram.
- If cables or wires are replaced, remove tags from old wire and place them on new wire.

Section III. HULL WIRING HARNESS - CONTINUED

7-6 WIRING HARNESS AND CABLE REPAIR - CONTINUED

NOTE

- All pins (male connectors) and sockets (female connectors) are alphabetically coded. Coded identification starts at connector key or groove.
- Male connectors' identifying letters run clockwise.
- Female connectors' identifying letters run counterclockwise.
- Do continuity checks upon completion of cable or harness repair.

a. Disassembly - Heat Shrink Insulation Sleeving.

Cut and discard insulation sleeving.

b. Assembly - Heat Shrink Insulation Sleeving.

NOTE

Insulation sleeving tubing should be twice the diameter of the part over which it will be shrunk.

- 1 Slide sleeving over wire and terminal.

NOTE

Remove thermal heat gun from sleeving as soon as sleeving forms to shape of wire and terminal.

- 2 Hold thermal heat gun 4 or 5 inches (101.6-127.0 mm) away from sleeving and apply heat for about 30 seconds.
- 3 Let sleeving cool 30 seconds before handling.

a. Disassembly - Wire Contacts.

- 1 Cut and discard contacts.
- 2 Strip about 1/2-inch (12.7 mm) of insulation from the end of the wire.

Section III. HULL WIRING HARNESS - CONTINUED

7-6 WIRING HARNESS AND CABLE REPAIR - CONTINUED

b. Assembly - Wire Contacts.

NOTE

Color bands on contacts indicate wire size. For example, contacts with green color bands are for 22-gage to 26-gage wire. Contacts with red color bands are for 20-gage to 24-gage wire.

- 1 Place contact in the crimping tool with the color band toward the rear.
- 2 Bare wire in the contact and squeeze the crimping tool.
- 3 Remove crimped contact out of the tool and check the crimp by looking in the inspection hole. Verify the end of the bare wire is visible.

a. Disassembly - Terminal-Type Cable Connectors.

NOTE

If repairing any of the following wiring harnesses, after assembly, seal open end of terminal crimp barrel with adhesive (item 3.1, Appx B).

Wiring Harness ID	Connector
W101	Leads AZ 10R, 10V, 81, 7, GNDW, BA and BB
W102	Leads AW, GNDZ, GNDN, AY and AX
W104	Leads 148 and 82
W105	Leads 452A, 82 and 7
W106	Lead 'L'
W107	Lead E3
W110	Leads E1, E2, E3 and E4
W112	GND lead
W113	Leads 452B, 459, 7 and GND
W116	Leads E1, E2, E3, E4, E5, E6, E7 and E8
W117	Leads E5, E6, E7 and E8
W119	Lead 7
W124	Lead E12
12370742	Leads E1, E2, E3 and E4

Cut and discard connector.

b. Assembly - Terminal-Type Cable Connectors.

- 1 Strip cable insulation equal to depth of terminal well.
- 2 Slide insulator (1) over cable (2).
- 3 Insert cable (2) into terminal well (3) and crimp.
- 4 Slide insulator (1) over crimped end of terminal (3).

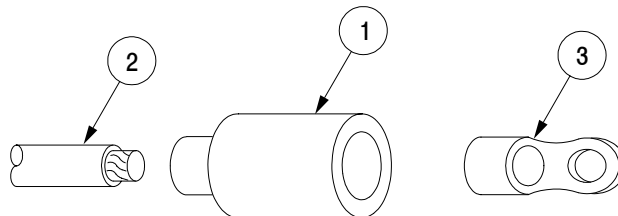

06ph060m

Section III. HULL WIRING HARNESS - CONTINUED

7-6 WIRING HARNESS AND CABLE REPAIR - CONTINUED

a. Disassembly - Female Cable Connector with Washer.

Cut and discard connector.

b. Assembly - Female Cable Connector with Washer.

- 1 Strip cable insulation approximately 1/8 inch (3.2 mm).
- 2 Slide shell (1) and washer (2) over cable (3).
- 3 Place cable (3) in cylinder end of terminal (4) and crimp.
- 4 Slide shell (1) and washer (2) over terminal (4).

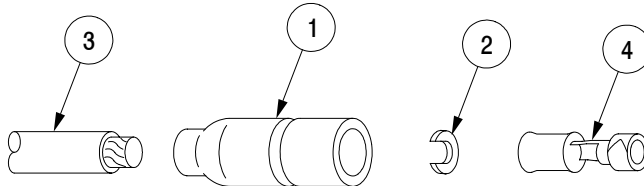

06ph035m

a. Disassembly - Male Cable Connector with Washer.

Cut and discard connector.

b. Assembly - Male Cable Connector with Washer.

- 1 Strip cable insulation equal to depth of terminal (1) well.
- 2 Slide shell (2) over cable.
- 3 Insert cable (3) into terminal well and crimp.
- 4 Place C-washer (4) over cable (3) at crimped junction and slide shell (2) over C-washer (4) and terminal (1).

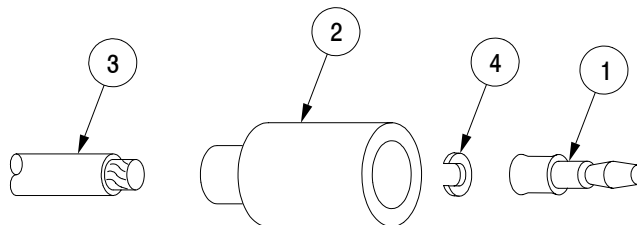

06ph033m

Section III. HULL WIRING HARNESS - CONTINUED

7-6 WIRING HARNESS AND CABLE REPAIR - CONTINUED

a. Disassembly - Female Cable Connector with Sleeve.

Cut and discard connector.

b. Assembly - Female Cable Connector with Sleeve.

- 1 Strip cable insulation approximately 1/8 inch (3.2 mm).
- 2 Slide shell (1) and sleeve (2) over cable (3).
- 3 Place cable (3) in cylinder end of terminal (4) and crimp.
- 4 Slide shell (1) and sleeve (2) over terminal (4).

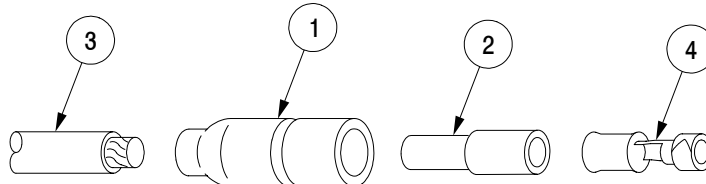

06ph036m

Waterproofing Connectors.

NOTE

If repairing any of the following wiring harness, during assembly apply a coat of viscous coating (item 27.1, Appx B) to connector threads.

Wiring Harness ID	Connector
W101	12361686-3 (J1) and 12361692 (P1)
W102	12361686-2 (J1)
W104	12361689-4 (J1)
W105	12361689-2 (J1), 12361693-1 (P1) and MS3456W22-5S (P3)
W111A	MS3450W22-19S (J1 and J4), 12361686-4 (J2 and J3), D38999/46WD5SN (P1)
W112	12361682-7 (P1)
W115	12361682-8 (P1), 12361682-4 (P2), 8724258 (P3), MS3456W22-23S (P4)
W119	8724245 (P1), MS3456W22-2P (P2), MS3456W22-22S (P3), MS3456W18-11S (P4)

Section III. HULL WIRING HARNESS - CONTINUED

7-6 WIRING HARNESS AND CABLE REPAIR - CONTINUED

Waterproofing Connectors - Continued

NOTE

If repairing any of the following wiring harnesses, during assembly apply a bead 360° about the connector grommet at the backshell interface (item 3, Appx B).

Wiring Harness ID	Connector
W101	12361686-3 (J1) and 12361692 (P1)
W102	12361686-2 (J1)
W104	12361689-4 (J1)
W105	12361689-2 (J1), 12361693-1 (P1) and MS3456W22-5S (P3)
W107	12361689-10 (J1)
W110	12361689-9 (J1)
W111A	MS3450W22-19S (J1 and J4), 12361686-4 (J2 and J3), D38999/46WD5SN (P1)
W112	12361682-7 (P1)
W115	12361682-8 (P1), 12361682-4 (P2), 8724258 (P3), MS3456W22-23S (P4)

a. Disassembly - Typical Male-Type Panel Mounting Receptacle.

- 1 Drive pin contacts (1) out through rear of insert (2) with pin extractor.
- 2 Unsolder cable (3) leads from solder wells on pin contacts (1).
- 3 Slide insert (2) out through rear of shell (4).

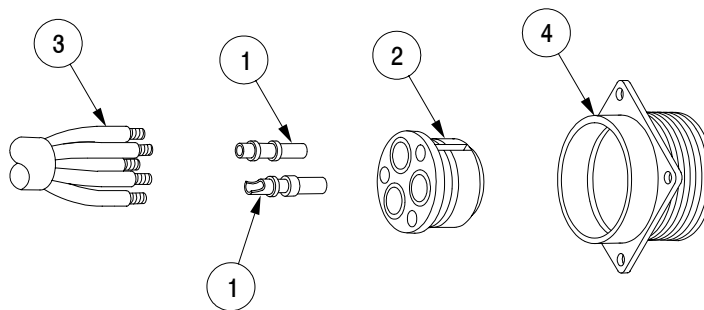

06ph069m

Section III. HULL WIRING HARNESS - CONTINUED

7-6 WIRING HARNESS AND CABLE REPAIR - CONTINUED

b. Assembly - Typical Male-Type Panel Mounting Receptacle.

- 1 Strip cable (3) insulation equal to depth of solder wells of pin contacts (1).
- 2 Insert cable (3) leads into solder wells of pin contacts (1) and solder.

NOTE

Groove in insert must be aligned with guide in shell to ensure proper fit.

- 3 Push insert (2) into shell (4) from rear until seated.
- 4 Push pin contacts (1) into insert (2) from rear until seated.

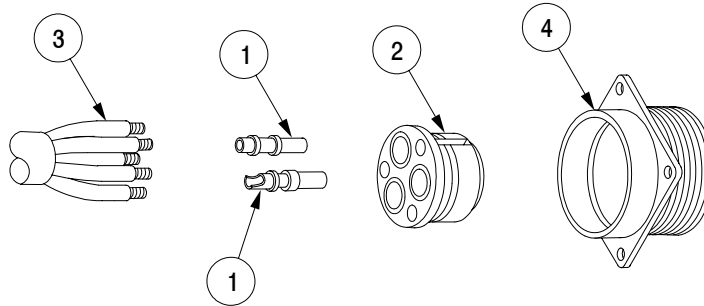

06ph069m

a. Disassembly - Typical Female-Type Panel Mounting Receptacle.

- 1 Drive socket contacts (1) out through rear of insert (2) with pin extractor.
- 2 Unsolder cable (3) leads from solder wells on socket contacts (1).
- 3 Slide insert (2) out through rear of shell (4).

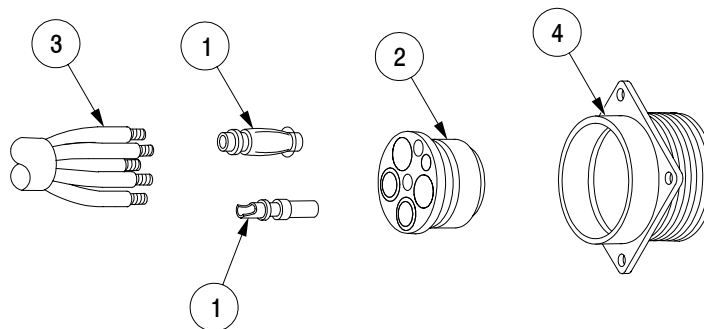

06ph070m

Section III. HULL WIRING HARNESS - CONTINUED

7-6 WIRING HARNESS AND CABLE REPAIR - CONTINUED

b. Assembly - Typical Female-Type Panel Mounting Receptacle.

- 1 Strip cable (3) insulation equal to depth of solder wells of socket contacts (1).
- 2 Insert cable (3) leads into solder wells of socket contacts (1) and solder.

NOTE

Groove in insert must be aligned with guide in shell to ensure proper fit.

- 3 Push insert (2) into shell (4) from rear until seated.
- 4 Push socket contacts (1) into insert (2) from rear until seated.

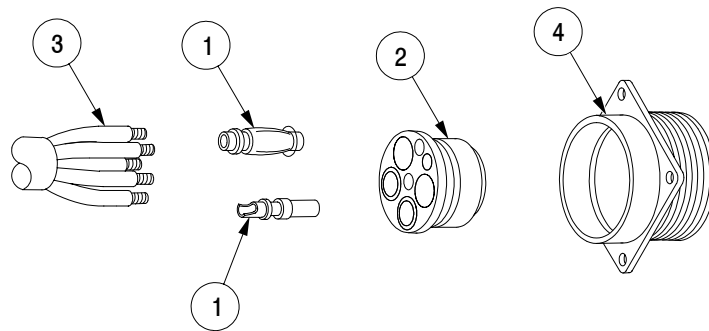

06ph070m

a. Disassembly - Typical Female-Type Panel Mounting Receptacle with Ridged Locking Nut.

- 1 Unscrew nut (1) from shell assembly (2) and slide back on cable (3).
- 2 Slide grommet (4) back on cable (3) leads.
- 3 Drive socket contacts (5) out through front of insert (6) with pin extractors.
- 4 Unsolder leads from socket contacts (5).
- 5 Push insert (6) out through rear of shell (7).

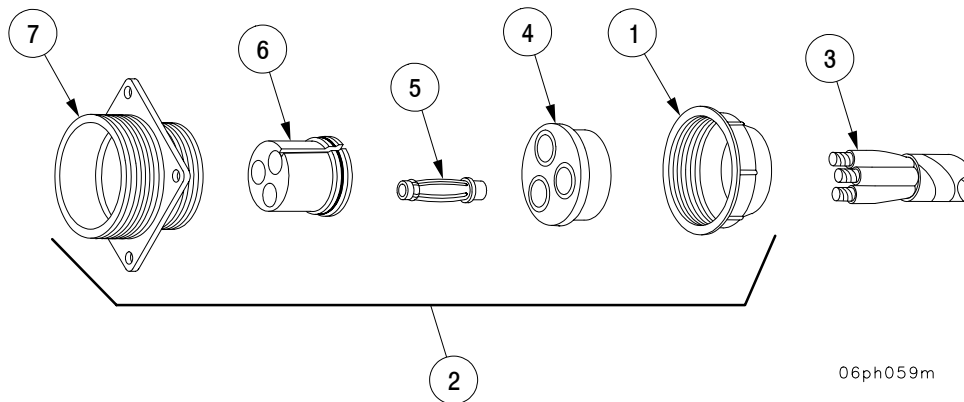

06ph059m

Section III. HULL WIRING HARNESS - CONTINUED

7-6 WIRING HARNESS AND CABLE REPAIR - CONTINUED

b. Assembly - Typical Female-Type Panel Mounting Receptacle with Ridged Locking Nut.

- 1 Strip cable (3) insulation equal to depth of solder wells of socket contacts (5).
- 2 Slide nut (1) over cable (3).
- 3 Slide grommet (4) over cable (3) leads.
- 4 Insert cable (3) leads into solder wells of socket contacts (5) and solder.

NOTE

Groove in insert must be aligned with guide in shell to ensure proper fit.

- 5 Push insert (6) into shell (7) from rear until seated.
- 6 Push socket contacts (5) into insert (6) from rear until seated.
- 7 Push grommet (4) down cable (3) leads and over solder wells of socket contacts (5).
- 8 Screw nut (1) onto shell assembly (2).

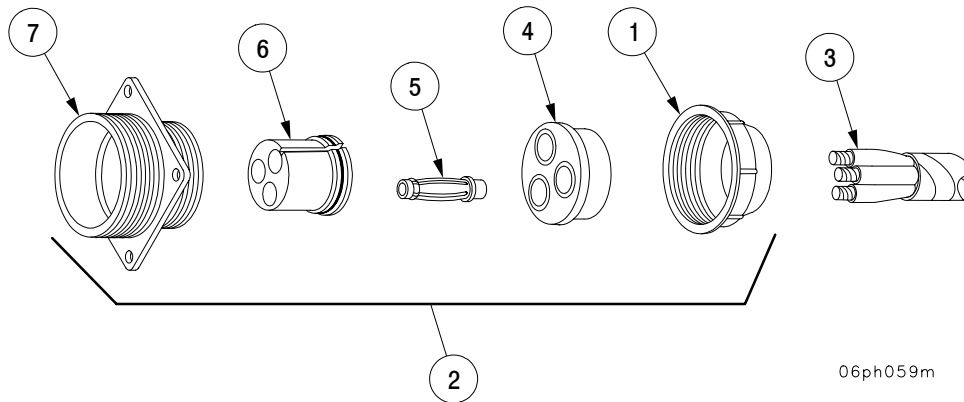

a. Disassembly - Typical Male-Type Panel Mounting Receptacle with Ridged Locking Nut.

- 1 Unscrew nut (1) from shell assembly (2) and slide back on cable (3).
- 2 Push grommet (4) back on cable (3) leads.
- 3 Drive pin contacts (5) out through rear of insert (6) with pin extractor.
- 4 Push insert (6) out through rear of shell (7).
- 5 Unsolder leads from pin contacts (5).

Section III. HULL WIRING HARNESS - CONTINUED

7-6 WIRING HARNESS AND CABLE REPAIR - CONTINUED

b. Assembly - Typical Male-Type Panel Mounting Receptacle with Ridged Locking Nut.

- 1 Strip cable (3) insulation equal to depth of solder wells of pin contacts (5).
- 2 Slide nut (1) onto cable (3).
- 3 Slide grommet (4) over cable (3) leads.
- 4 Insert cable (3) leads into solder wells of pin contacts (5) and solder.

NOTE

Groove in insert must be aligned with guide in shell to ensure proper fit.

- 5 Push insert (6) into shell (7) from rear until seated.
- 6 Push pin contacts (5) into insert (6) from rear until seated.
- 7 Push grommet (4) down cable (3) leads and over solder wells of pin contacts (5).
- 8 Screw nut (1) onto shell assembly (2).

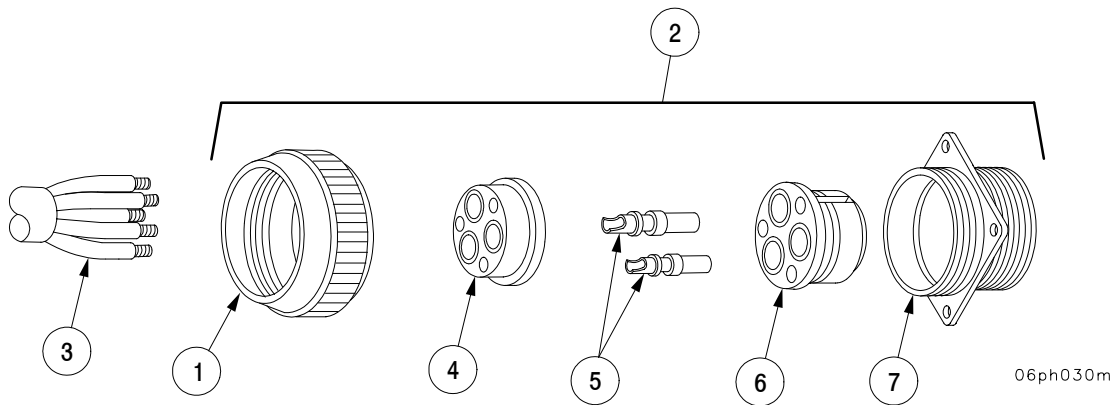

Section III. HULL WIRING HARNESS - CONTINUED

7-6 WIRING HARNESS AND CABLE REPAIR - CONTINUED

a. Disassembly - Typical Female-Type Plug with Ridged Locking Nut.

- 1 Unscrew nut (1) from shell assembly (2) and slide back on cable (3).
- 2 Slide grommet (4) back on cable (3) leads.
- 3 Slide coupling nut (5) off shell (6).
- 4 Drive socket contacts (7) out through rear of insert (8) with pin extractor.
- 5 Push insert (8) out through rear of shell (6).
- 6 Unsolder leads from socket contacts (7).

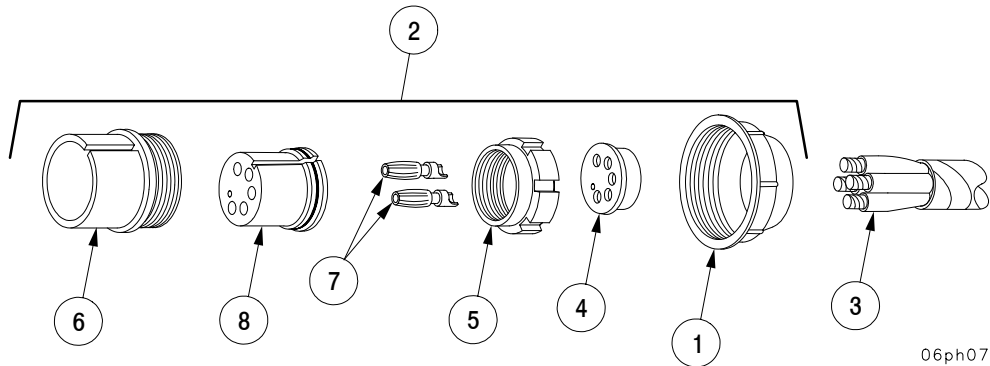

b. Assembly - Typical Female-Type Plug with Ridged Locking Nut.

- 1 Strip cable (3) insulation equal to depth of solder wells of socket contacts (7).
- 2 Slide nut (1) over cable (3) leads.
- 3 Slide grommet (4) over cable (3) leads.
- 4 Insert cable (3) leads into solder wells of socket contacts (7) and solder.

NOTE

Groove in insert must be aligned with guide in shell to ensure proper fit.

- 5 Push insert (8) into shell (6) from rear until seated.
- 6 Push socket contacts (7) into insert (8) from rear until seated.
- 7 Slide coupling nut (5) onto shell assembly (2).
- 8 Push grommet (4) down cable (3) leads and over solder wells of socket contacts (7).
- 9 Screw nut (1) onto shell assembly (2).

Section III. HULL WIRING HARNESS - CONTINUED

7-6 WIRING HARNESS AND CABLE REPAIR - CONTINUED

a. Disassembly - Typical Male-Type Plug with Ridged Locking Nut.

- 1 Unscrew nut (1) from shell assembly (2) and slide back on cable (3).
- 2 Slide grommet (4) back on cable (3) leads.
- 3 Slide coupling nut (5) off shell assembly (2).
- 4 Drive pin contacts (6) out through rear of insert (7) with pin extractor.
- 5 Push insert (7) out through rear of shell (8).
- 6 Unsolder cable (3) leads from pin contacts (6).

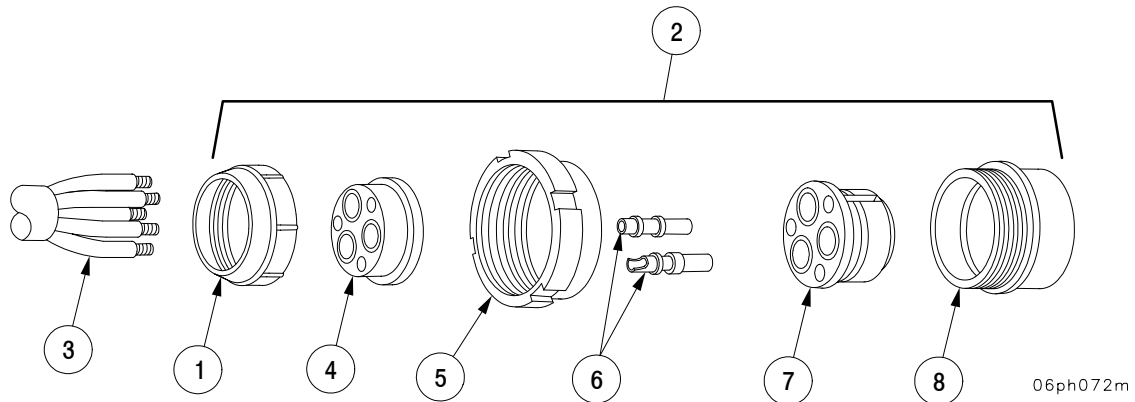

Section III. HULL WIRING HARNESS - CONTINUED

7-6 WIRING HARNESS AND CABLE REPAIR - CONTINUED

b. Assembly - Typical Male-Type Plug with Ridged Locking Nut.

- 1 Strip cable (3) of insulation equal to depth of solder wells of pin contacts (6).
- 2 Slide nut (1) over cable (3).
- 3 Slide grommet (4) over cable (3) leads.
- 4 Insert cable (3) leads into solder wells of pin contacts (6) and solder.

NOTE

Groove in insert must be aligned with guide in shell to ensure proper fit.

- 5 Push insert (7) into shell (8) from rear until seated.
- 6 Push pin contacts (6) into insert (7) from rear until seated.
- 7 Slide coupling nut (5) onto shell assembly (2).
- 8 Push grommet (4) down cable (3) leads and over solder wells of pin contacts (6).
- 9 Screw nut (1) onto shell assembly (2).

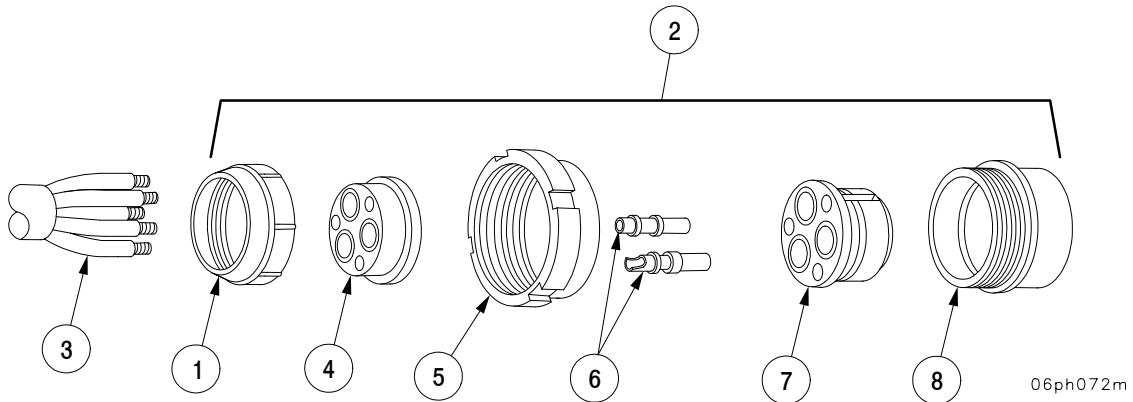

Section III. HULL WIRING HARNESS - CONTINUED

7-6 WIRING HARNESS AND CABLE REPAIR - CONTINUED

a. Disassembly - Connectors from Cable/Wiring Harness with Dust and Moisture Boots.

NOTE

- If dust and moisture boot is bulk insulation sleeving type, begin with step 1. If dust and moisture boot is preformed, precut type go to step 2.
- Boot may be attached to adapter/backshell rather than to jack or plug. Procedure is the same for attaching boot to jack, plug, or adapter/backshell.
- When adapter is mentioned in this procedure, it could be an adapter or backshell.

1 Remove bulk insulation sleeving type boot as follows:

- a Cut boot (1) off harness jacket (2) and adapter (3).

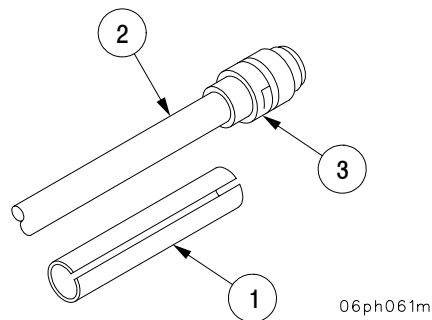

- b Loosen adapter (3) from connector (4) with soft jaw pliers and connector wrench.
 c Pull adapter (3) away from connector (4) to reach wire(s) (5).
 d Disconnect wire(s) (5) from connector (4).
 e Remove connector (4) and adapter (3) from cable (6). Go to step 3.

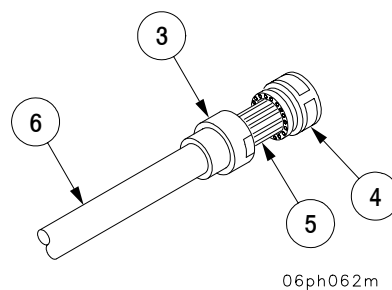

Section III. HULL WIRING HARNESS - CONTINUED

7-6 WIRING HARNESS AND CABLE REPAIR - CONTINUED

a. Disassembly - Connectors from Cable/Wiring Harness with Dust and Moisture Boots - Continued

- 2 Remove precut type boot as follows:
 - a Loosen adapter (1) from connector (2) with soft jaw pliers and connector wrench.



Too much heat will damage boot.

- b Using heat gun, heat boot (3) until warm to touch. Slide boot (3) and adapter (1) away from connector (2).
 - c Unscrew adapter (1) from connector (2) and pull adapter (2) and boot (3) away from connector (2). Hold adapter (1) back until boot (3) cools.
 - d Disconnect wire(s) (4) from connector (2).
 - e Remove connector (2), adapter (1), and boot (3) from cable (5).
- 3 Remove adhesive from connector(s).

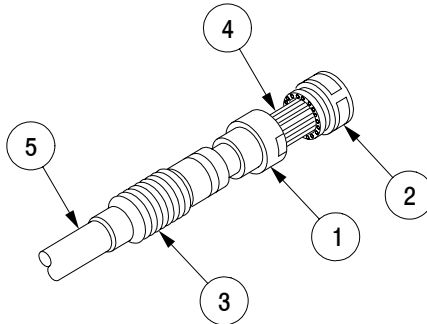

06ph063m

Section III. HULL WIRING HARNESS - CONTINUED

7-6 WIRING HARNESS AND CABLE REPAIR - CONTINUED

b. Assembly - Connectors onto Cable/Wiring Harness with Dust and Moisture Boots.

- 1 Prepare bonding areas as follows:
 - a Rough up bonding area (1) and inside ends (2) of boot (3). Use abrasive cloth.
 - b Wipe dust from bonding area (1) and inside ends (2) of boot (3). Use clean wiping rag.

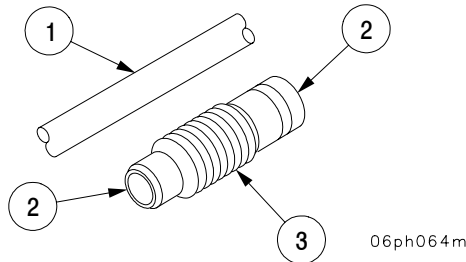

- 2 Install bulk insulation sleeving type boot or precut boot as follows:
 - a Slide boot (3) and adapter (4) over cable (5).
 - b Install connector (6) on cable (5) and connect wires (7).
 - c Install adapter (4) on connector (6).
 - d Wrap bonding areas of cable (5) and adapter (4) with sealant tape.
 - e Position boot (3) on adapter (4) and cable (5).

CAUTION

Too much heat will damage boot.

- f Heat shrink boot (3) on adapter (4) and cable (5).

CAUTION

Too much heat will damage boot.

NOTE

If boot was pulled back on wires, away from connector, go to step 3.

- 3 Apply a 1/4 inch (6.4 mm) bead of adhesive around adapter (4) on connector (6).
- 4 Heat boot (3) warm to touch and slide over adapter (4).

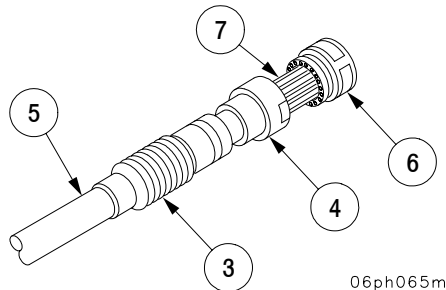

Section IV. VENTILATING EQUIPMENT.

7-7 PERSONNEL VENTILATING AIR DUCT FAN.

This task covers: a. Disassembly b. Inspection c. Assembly d. Test

INITIAL SETUP

Tools

Fuel and electrical tool kit
(SC 5180-95-B08)
Multimeter (item 31, Appx F)
Growler (item 20, Appx F)
Pliers, wire twisting (item 34, Appx F)

Materials/Parts

Spring tension washer (item 31, Appx E)
Lockwire (AR) (item 49, Appx E)
Snappings (2) (item 44, Appx E)
Grommet (item 83, Appx E)
Lockwashers (4) (item 15, Appx E)
Lockwashers (2) (item 70, Appx E)

Equipment Conditions

Personnel ventilating air duct fan removed
(TM 9-2350-314-20-1-2)

Personnel Required

Two

References

TM 9-214
TM 9-2350-314-20-1-2

a. Disassembly.

- 1 Block impeller (1) to prevent rotation.
- 2 Remove nut (2), flat washer (3), impeller (1), key (4), and flatwasher (5) from blower assembly housing (6).
- 3 Remove two nuts (7), two lockwashers (8), and noise filter cover (9) from noise filter (10). Discard lockwashers.

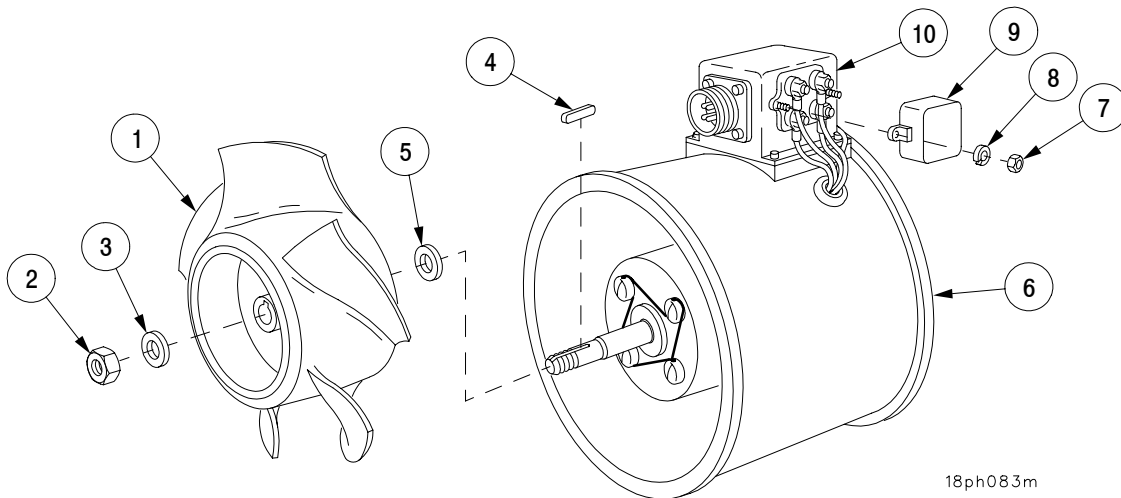

Section IV. VENTILATING EQUIPMENT - CONTINUED

7-7 PERSONNEL VENTILATING AIR DUCT FAN - CONTINUED

a. Disassembly - Continued
NOTE

Prior to disconnecting wires, tag all electrical connections to ensure proper installation.

- 4 Remove four nuts (11), four lockwashers (12), and four electrical leads (13) from noise filter terminals (14). Discard lockwashers.
- 5 Remove lockwire (15), four screws (16), four flat washers (17), ground wire lead (18), and noise filter (10) from blower assembly (6). Discard lockwire.
- 6 Remove lockwire (19), four screws (20), and four flat washers (21) at front of blower assembly housing (6). Discard lockwire.
- 7 Remove grommet (22) from blower assembly housing (6). Feed four electrical leads (13) and ground wire lead (18) through grommet (22) to avoid damaging wires. Discard grommet.

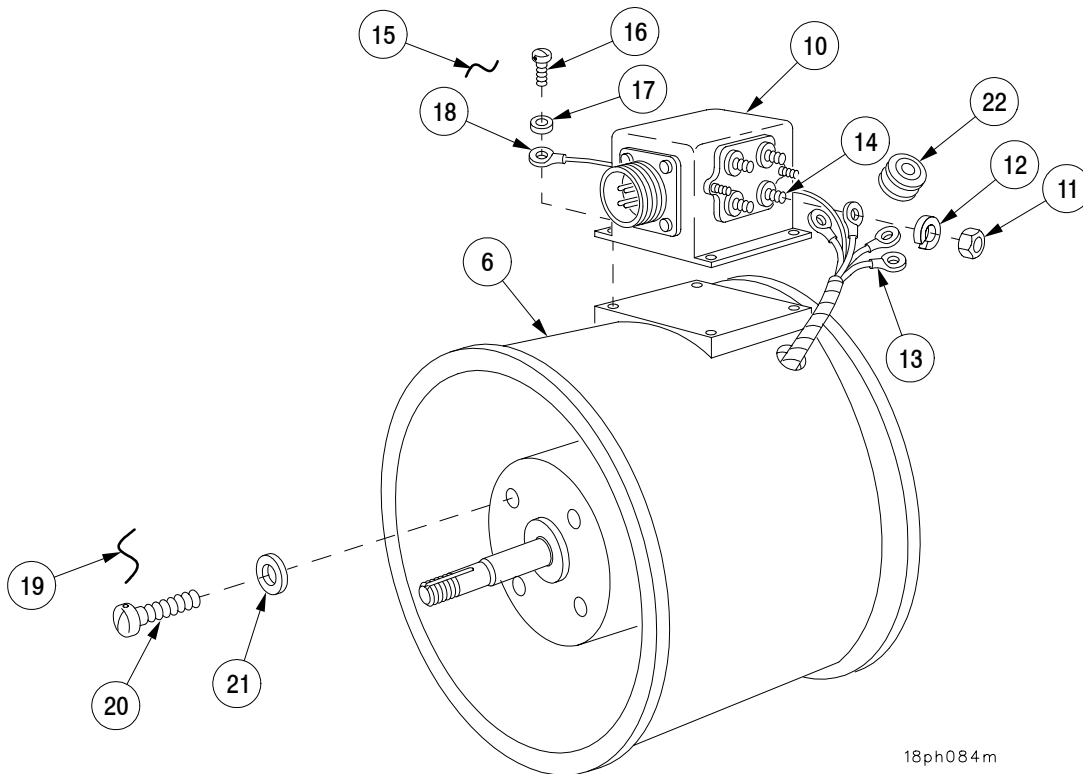

18ph084m

Section IV. VENTILATING EQUIPMENT - CONTINUED

7-7 PERSONNEL VENTILATING AIR DUCT FAN - CONTINUED

a. Disassembly - Continued

- 8 Remove identification plate (23) from blower assembly housing (6), if damaged.
- 9 Remove motor assembly (24) from blower assembly housing (6).
- 10 Remove two screws (25) and end cover (26).
- 11 Remove two brush caps (27) and two electrical brushes (28).

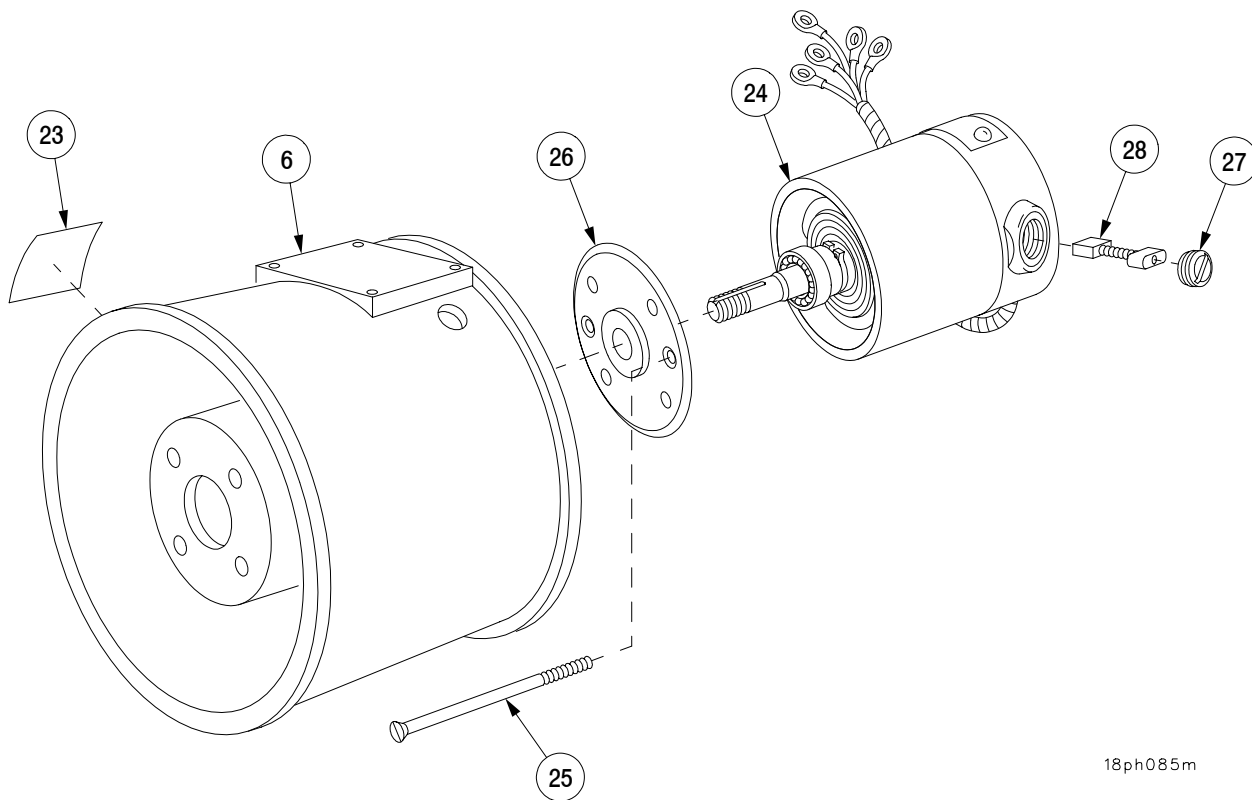

18ph085m

Section IV. VENTILATING EQUIPMENT - CONTINUED

7-7 PERSONNEL VENTILATING AIR DUCT FAN - CONTINUED

a. Disassembly - Continued

- 12 Remove armature (29) from motor field and frame assembly (30).

WARNING

Use care when removing snap and retaining rings. Snap and retaining rings are under spring tension and can act as projectiles when released and could cause severe eye injury.

- 13 Remove flat washer (31), spring tension washer (32), bearing (33), flat washer (34), snapping (35), and flat washer (36) from armature (29). Discard snapping and spring tension washer.
- 14 Remove bearing (37), flat washer (38), snapping (39), and flat washer (40) from armature (29). Discard snapping.
- 15 Remove two rivets (41) and identification plate (42) from frame assembly (30) if damaged. Discard rivets.

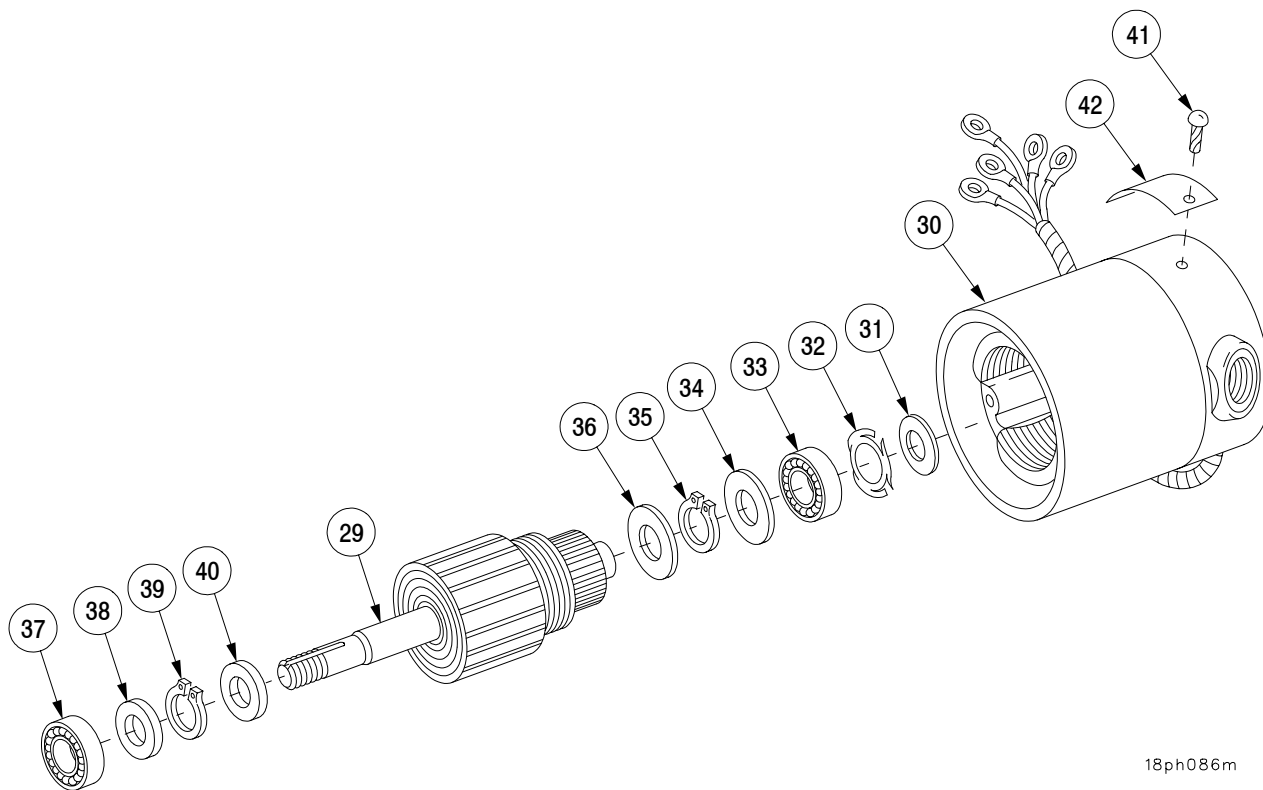

18ph086m

Section IV. VENTILATING EQUIPMENT - CONTINUED

7-7 PERSONNEL VENTILATING AIR DUCT FAN - CONTINUED

b. Inspection.

- 1 Inspect impeller (1) for nicks and cracks. If nicks and/or cracks are found, replace fan assembly.
- 2 Test noise filter (10) for continuity using multimeter. If continuity does not exist between pins "C" and "D" and pins "A" and "B", pin "A" and terminal "A", pin "B" and terminal "B", pin "C" and terminal "C", and pin "D" and terminal "D", replace noise filter.
- 3 Inspect blower assembly housing (6). Repair damage as appropriate. Inspect for impeller rubbing on housing. Straighten housing or remove high spots as appropriate. If housing is unserviceable, replace fan assembly.
- 4 Inspect shaft key (4). Replace if damaged.

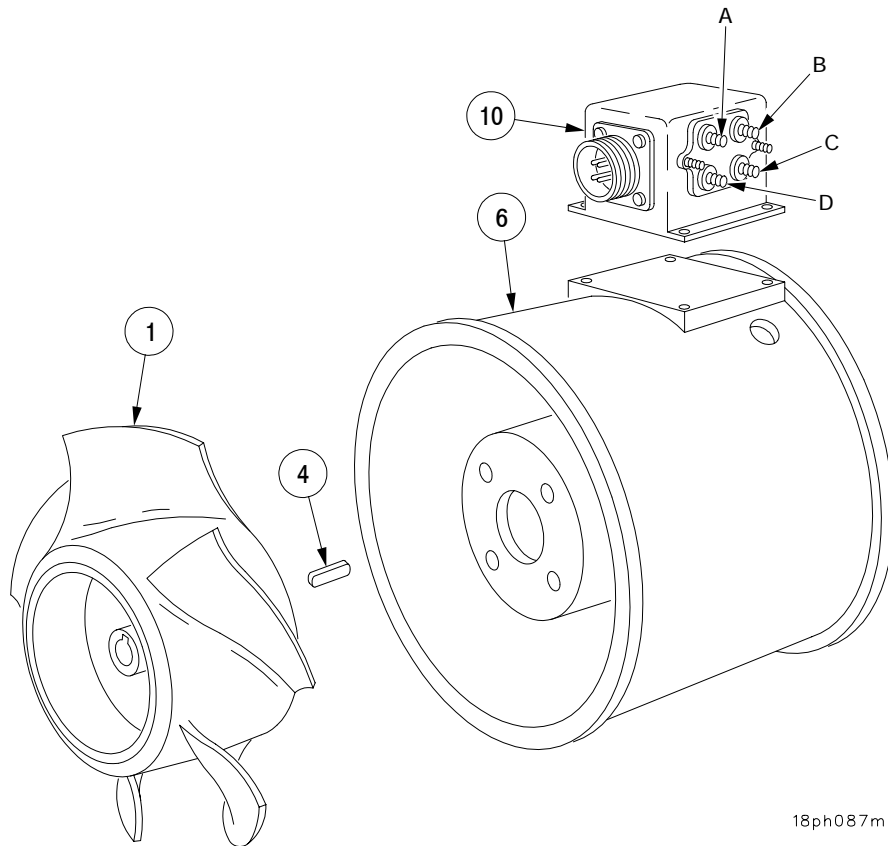

18ph087m

Section IV. VENTILATING EQUIPMENT - CONTINUED

7-7 PERSONNEL VENTILATING AIR DUCT FAN - CONTINUED

b. Inspection - Continued

- 5 Check length on two electrical brushes (28). If length is less than 1/4 in., replace.
- 6 Inspect two brush caps (27). Replace if threads are damaged.

NOTE

If armature and/or motor field and frame assembly are damaged or defective, or if armature shaft is worn beyond the limits for proper bearing fit, replace motor assembly as a unit.

- 7 Test armature (29) on growler. If defective, replace motor assembly (24).
- 8 Test motor field and frame assembly (30) for short or open field windings using multimeter. If defective, replace motor assembly (24).
- 9 Inspect two bearings (33 and 37) for damage or defects (TM 9-214). Replace if defective.

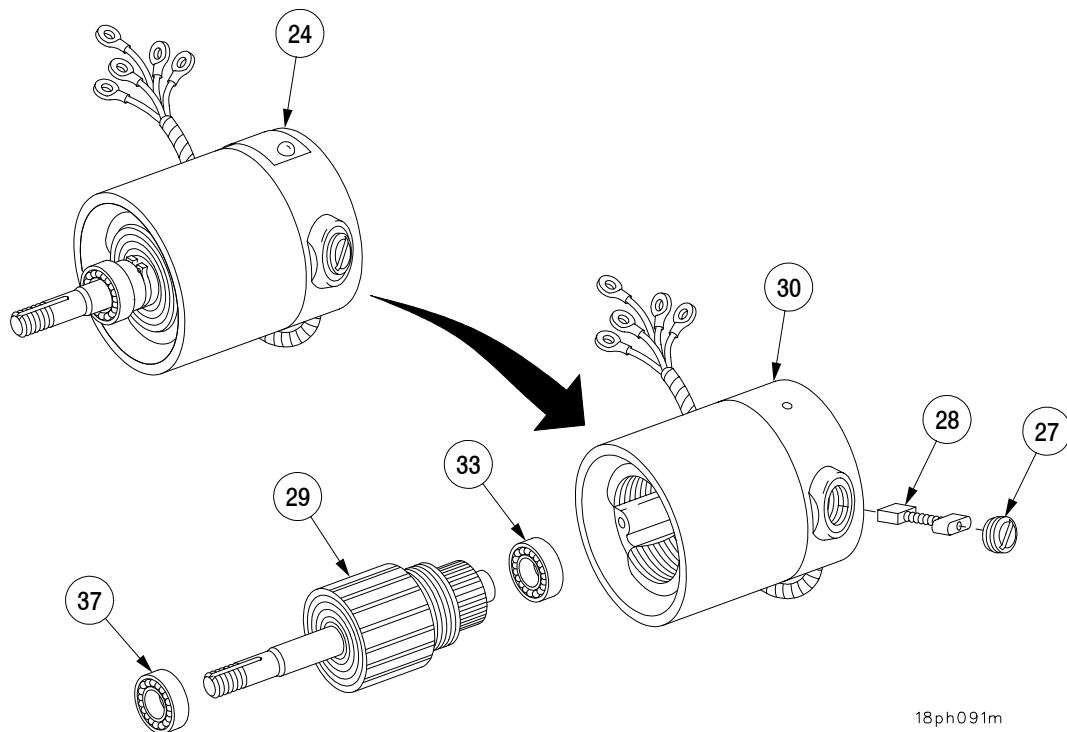

18ph091m

Section IV. VENTILATING EQUIPMENT - CONTINUED

7-7 PERSONNEL VENTILATING AIR DUCT FAN - CONTINUED

c. Assembly.

- 1 Install identification plate (42), if removed on frame assembly (30) with two new rivets (41).
- 2 Install flat washer (31) and new spring tension washer (32) into motor field and frame assembly (30).

WARNING

Use care when installing snap and retaining rings. Snap and retaining rings are under spring tension and can act as projectiles when released and could cause severe eye injury.

- 3 Install flat washer (36), new snapping (35), flat washer (34), and bearing (33) on armature (29).
- 4 Install armature (29) in motor field and frame assembly (30).
- 5 Install flat washer (40), new snapping (39), flat washer (38), and bearing (37) on armature (29).

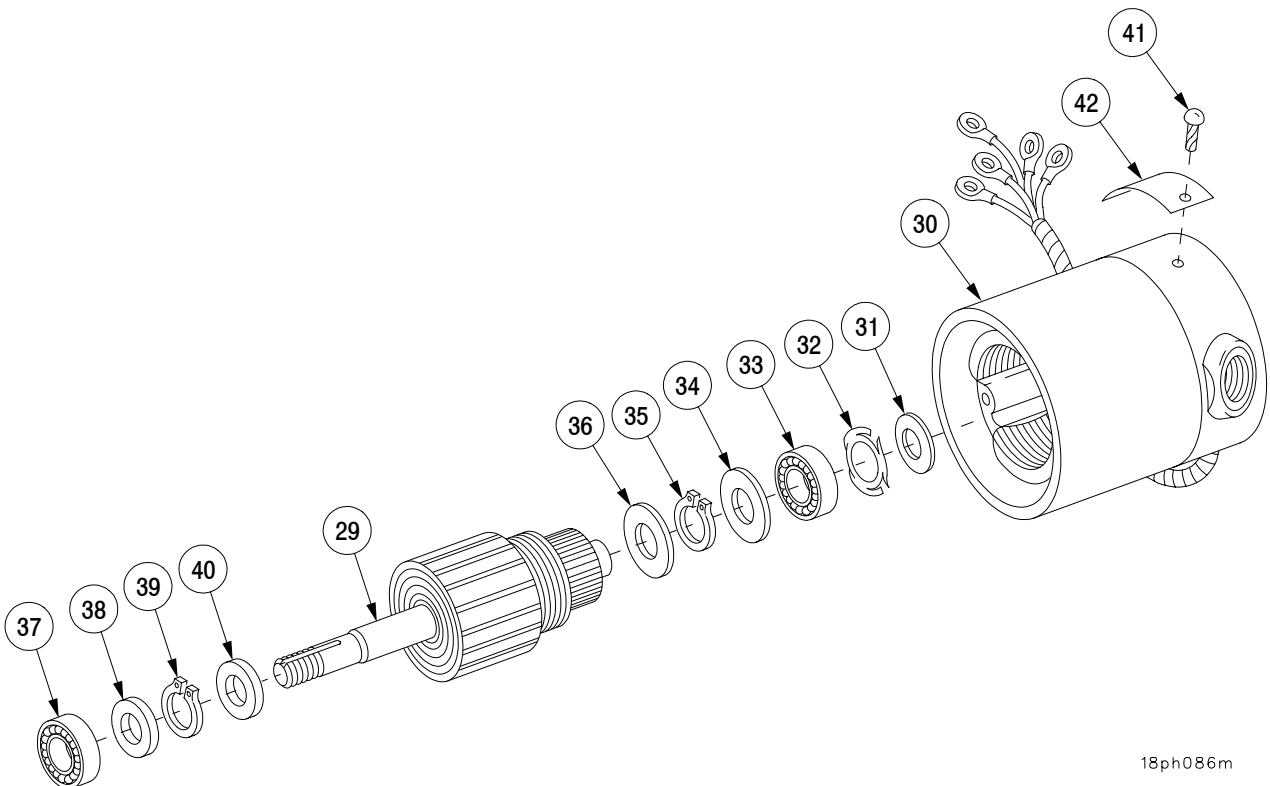

18ph086m

Section IV. VENTILATING EQUIPMENT - CONTINUED

7-7 PERSONNEL VENTILATING AIR DUCT FAN - CONTINUED

c. Assembly - Continued

- 6 Install two electrical brushes (28) and two brush caps (27) in motor assembly (24).
- 7 Install end cover (26) with two screws (25) on motor assembly (24).
- 8 Install motor assembly (24) in blower assembly housing (6) by feeding four electrical leads (13) and ground wire lead (18) carefully through new grommet (22). Install new grommet (22) in blower assembly housing (6).
- 9 Secure motor assembly (24) to blower assembly housing (6) with four screws (20), four flat washers (21), and new lockwire (19).
- 10 Install identification plate (23) on blower assembly housing (6), if removed.

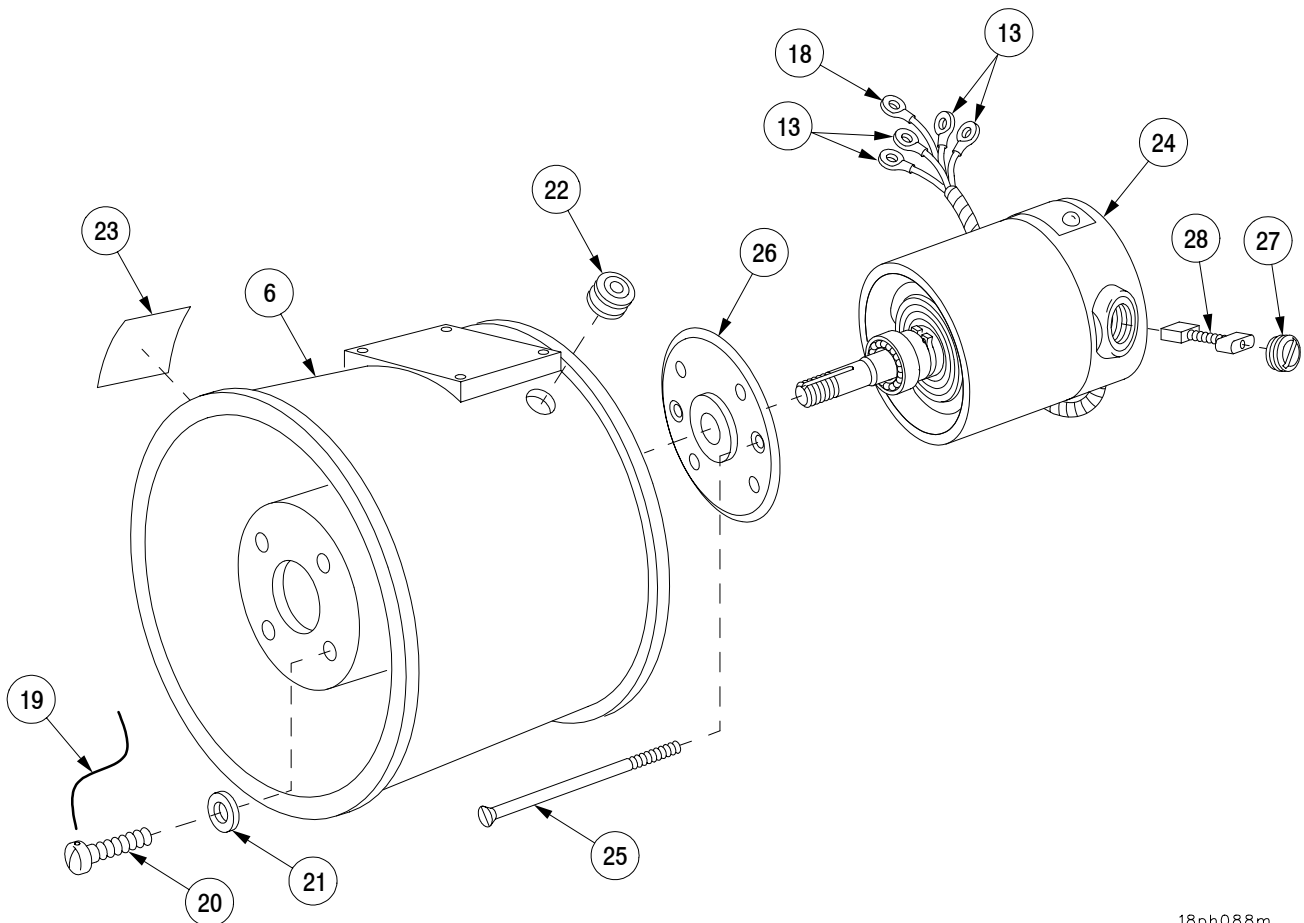

18ph088m

Section IV. VENTILATING EQUIPMENT - CONTINUED

7-7 PERSONNEL VENTILATING AIR DUCT FAN - CONTINUED

c. Assembly - Continued

- 11 Install noise filter (10) and ground wire lead (18) on blower assembly housing (6) with four screws (16), four flat washers (17), and new lockwire (15).
- 12 Connect four electrical leads (13) to noise filter terminals (14) with four new lockwashers(12) and four nuts (11).

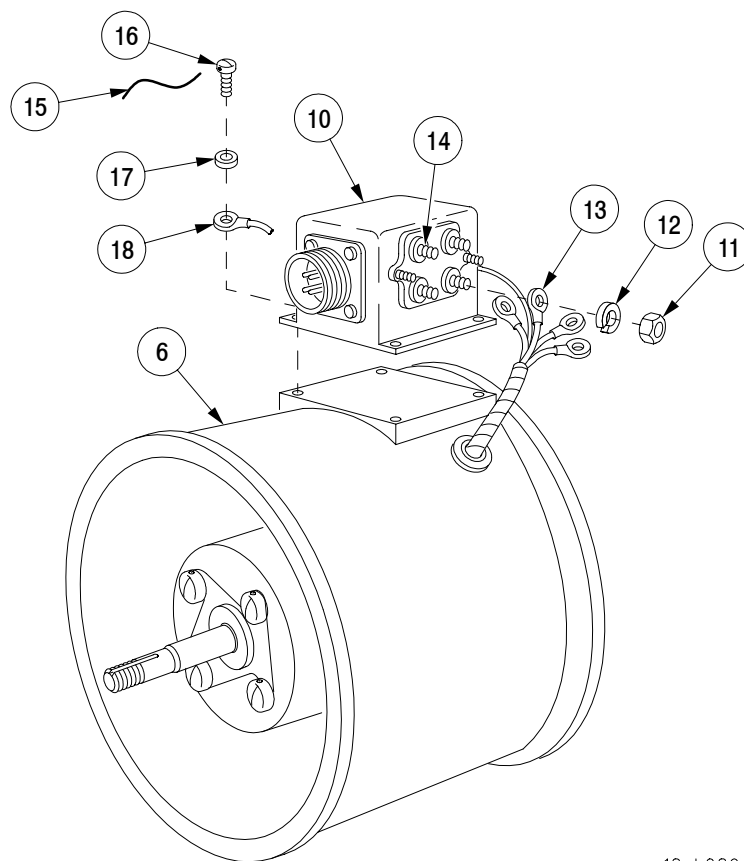

18ph089m

Section IV. VENTILATING EQUIPMENT - CONTINUED

7-7 PERSONNEL VENTILATING AIR DUCT FAN - CONTINUED

c. Assembly - Continued

- 13 Install noise filter cover (9) with two new lockwashers (8) and two nuts (7).
- 14 Install flat washer (5), key (4), impeller (1), flat washer (3), and nut (2).

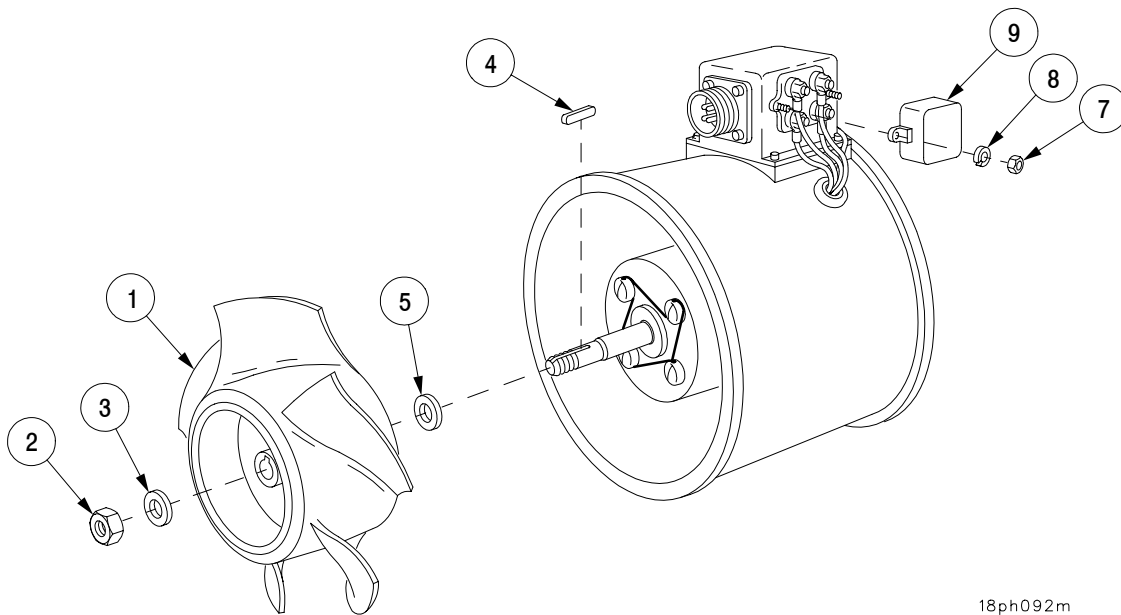

18ph092m

Section IV. VENTILATING EQUIPMENT - CONTINUED

7-7 PERSONNEL VENTILATING AIR DUCT FAN - CONTINUED

WARNING

Be careful when working with live circuits. Jewelry should be removed prior to working with live circuits. Failure to do this may result in personnel injury or electrical shock.

d. Test

Using 24 V dc power source, test ventilating air duct fan as follows using schematic.

- 1 Clockwise Rotation:
 - a Using jumper wire, connect pin A to pin C on fan receptacle.
 - b Connect positive lead of power source to pin B of fan receptacle.
 - c Connect negative lead of power source to pin D of fan receptacle.
- 2 Counterclockwise Rotation:
 - a Using jumper wire, connect pin B to pin C on fan receptacle.
 - b Connect positive lead of power source to pin A of fan receptacle.
 - c Connect negative lead of power source to pin D of fan receptacle.

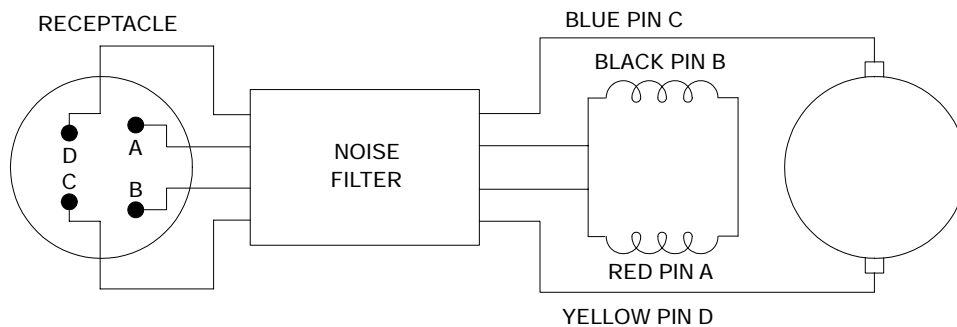

NOISE FILTER SCHEMATIC DIAGRAM

18ph090m

NOTE

FOLLOW-ON MAINTENANCE:
 Install personnel ventilation air duct fan
 (TM 9-2350-314-20-1-2)

CHAPTER 8 WHEELS AND TRACKS

GENERAL

This chapter illustrates and defines direct support procedures for removal, disassembly, inspection, assembly, and installation of the suspension assembly and track-related components.

<u>CONTENTS</u>	<u>Page</u>
Section I. SUSPENSION ASSEMBLY	
8-1 TORSION BAR ANCHOR AND COVER PLATE, POSITION THREE	8-2
Section II. TRACK IDLERS AND BRACKETS	
8-2 TRACK ADJUSTER CYLINDER ASSEMBLY	8-4

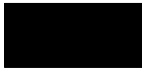

Section I. SUSPENSION ASSEMBLY.

8-1 TORSION BAR ANCHOR AND COVER PLATE, POSITION THREE.

This task covers: a. Removal b. Installation

INITIAL SETUP

Tools

General mechanic's tool kit
 (SC 5180-90-N26)
 Torque wrench (item 59, Appx F)
 Socket (item 42, Appx F)
 Extension (item 18, Appx F)
 Holder, screwdriver bit (item 25, Appx F)
 Ratchet handle (item 22, Appx F)
 Wire twisting pliers (item 34, Appx F)
 Torque wrench (item 57, Appx F)
 Adapter, screwdriver (item 1, Appx F)

Materials/Parts

Lockwire (item 49, Appx E)
 Sealing compound (item 24, Appx B)
 Dry-cleaning solvent (item 29, Appx B)
 Grease (item 13, Appx B)

Equipment Conditions

Torsion bars removed
 (TM 9-2350-314-20-1-2)
 Lower fuel tank removed (para 5-2)

References

TM 9-2350-314-20-1-2

a. Removal.

- 1 Remove 23 screws (1) and three cover plates (2).
- 2 Remove and discard lockwire (3).
- 3 Remove four screws (4), eight flat washers (5), and two anchors (6).

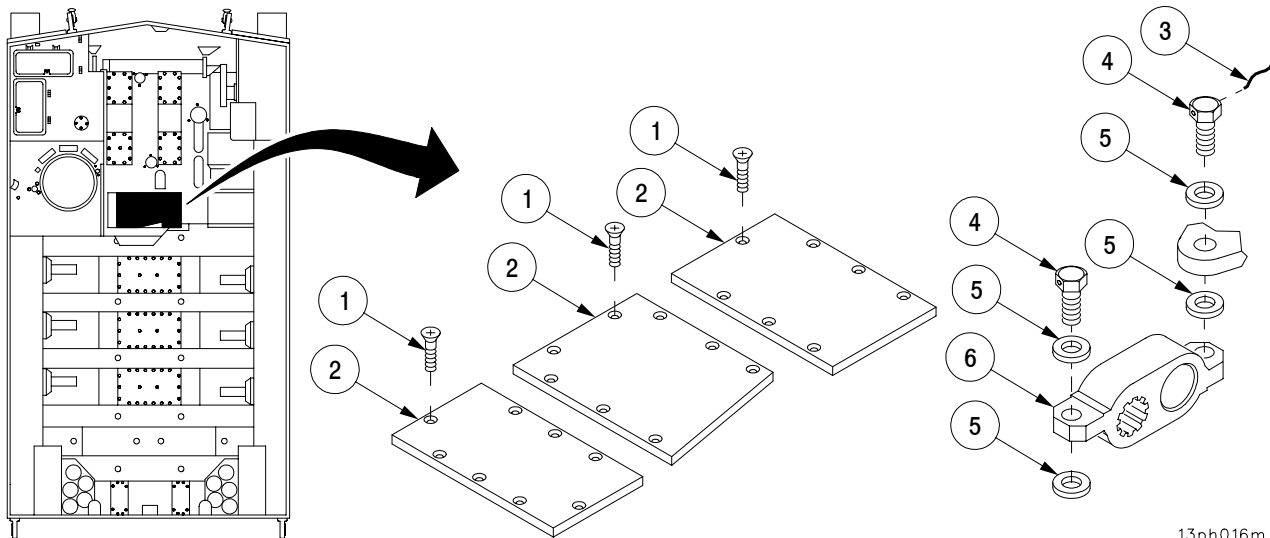

13ph016m

Section I. SUSPENSION ASSEMBLY - CONTINUED

8-1 TORSION BAR ANCHOR AND COVER PLATE, POSITION THREE - CONTINUED

b. Installation.

WARNING

Dry-cleaning solvent (P-D-680), used to clean parts, is toxic and flammable. Wear protective goggles and gloves and use only in a well-ventilated area. Avoid contact with skin, eyes, and clothes. Do not breathe vapors. Do not use near open flame or excessive heat. Do not smoke when using solvent. Failure to do so could cause **SERIOUS INJURY**. If you become dizzy while using dry-cleaning solvent, get fresh air immediately, and if necessary, get medical attention. If contact with skin or clothes is made, flush thoroughly with water. If the solvent contacts your eyes, wash them with water immediately and obtain medical aid (ref. FM 21-11).

- 1 Remove any water or dirt in torsion bar cavity. Dry thoroughly and clean using dry-cleaning solvent.
- 2 Install two anchors (6), four screws (4), and eight flat washers (5). Torque screws to 230-260 lb-ft (311-352 N·m).
- 3 Install new lockwire (3) on four screws (4).
- 4 Coat torsion bar anchors (6) with grease.
- 5 Apply sealing compound around edge of cover plates (2) and to threads of screws (1).
- 6 Install three cover plates (2) and 23 screws (1). Torque screws to 15-20 lb-ft (20-27 N·m).

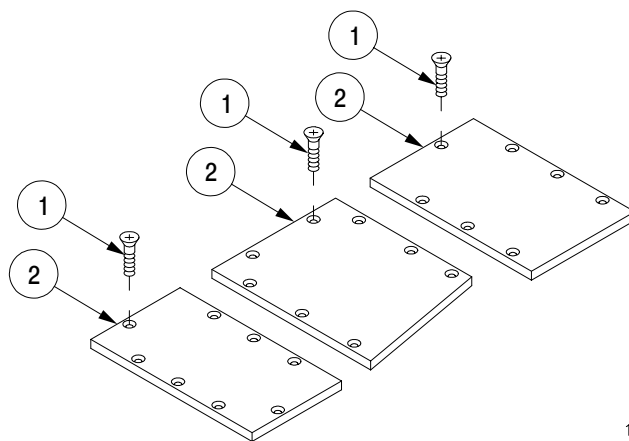
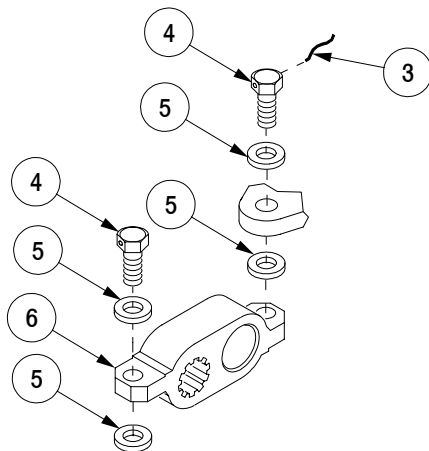

13ph019m

NOTE
FOLLOW-ON MAINTENANCE:

- Install lower fuel tank (para 5-2)
- Install torsion bars (TM 9-2350-314-20-1-2)

Section II. TRACK IDLERS AND BRACKETS.

8-2 TRACK ADJUSTER CYLINDER ASSEMBLY.

This task covers: a. Disassembly b. Assembly

INITIAL SETUP

Tools

General mechanic's tool kit
(SC 5180-90-N26)
Arbor press (item 5, Appx F)
Torque wrench (item 59, Appx F)
Machinist's vise (item 53, Appx F)
Vise jaw caps (item 11, Appx F)
Spanner wrench set (item 56, Appx F)

Equipment Conditions

Track adjuster removed
(TM 9-2350-314-20-1-2)

References

TM 9-214
TM 9-2350-314-20-1-2

Materials/Parts

Parts kit (item 23, Appx E)
Dry-cleaning solvent (item 29, Appx B)
Automotive grease (item 13, Appx B)
Antiseizing tape (item 33, Appx B)

a. Disassembly.

- 1 Place cylinder (1) in vise.
- 2 Remove bleeder plug (2), and bleeder body (3) from cylinder (1).
- 3 Remove nut (4) and piston (5) from cylinder (1).

WARNING

Use care when removing retainers and scraper.
Retainers and scrapers are under spring tension and
can act as projectiles when released and could cause
severe eye injury.

- 4 Remove two retainers (6) and preformed packing (7) from piston (5). Discard retainers and preformed packing.
- 5 Remove nut (4) from piston (5).
- 6 Remove scraper (8) and preformed packing (9) from nut (4). Discard scraper and preformed packing.
- 7 Remove lubricating fitting (10) from cylinder (1).

Section II. TRACK IDLERS AND BRACKETS - CONTINUED

8-2 TRACK ADJUSTER CYLINDER ASSEMBLY - CONTINUED

a. Disassembly - Continued

- 8 Inspect two bearings (11) in accordance with TM 9-214.

NOTE

Perform step 9 if bearings are to be replaced.

- 9 Remove bearing(s) (11) from cylinder (1) and/or piston (5).

WARNING

Dry-cleaning solvent (P-D-680), used to clean parts, is toxic and flammable. Wear protective goggles and gloves and use only in a well-ventilated area. Avoid contact with skin, eyes, and clothes. Do not breathe vapors. Do not use near open flame or excessive heat. Do not smoke when using solvent. Failure to do so could cause **SERIOUS INJURY**. If you become dizzy while using dry-cleaning solvent, get fresh air immediately, and if necessary, get medical attention. If contact with skin or clothes is made, flush thoroughly with water. If the solvent contacts your eyes, wash them with water immediately and obtain medical aid (ref. FM 21-11).

- 10 Clean all parts with dry-cleaning solvent.

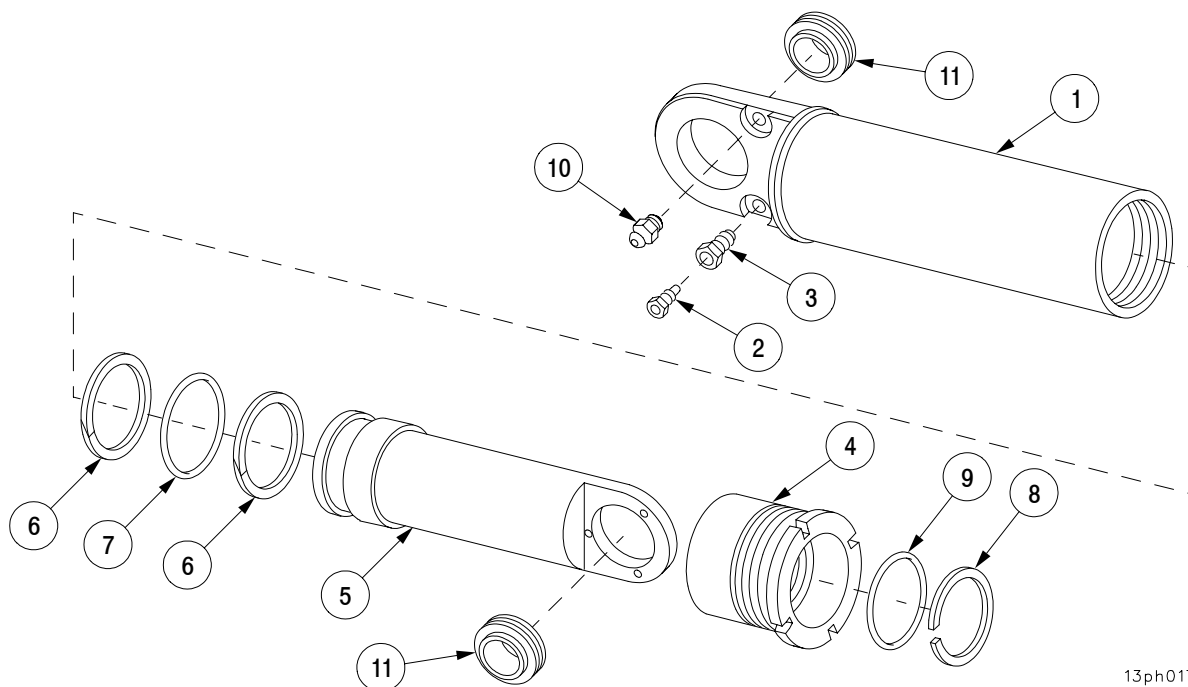

13ph017m

Section II. TRACK IDLERS AND BRACKETS - CONTINUED

8-2 TRACK ADJUSTER CYLINDER ASSEMBLY - CONTINUED

b. Assembly.

NOTE

Perform step 1 if bearings were removed.

- 1 Install bearing(s) (11) in cylinder (1) and/or piston (5).
- 2 Coat inside of cylinder (1) with grease.
- 3 Place cylinder (1) in vise.
- 4 Install lubricating fitting (10) in cylinder (1).

WARNING

Use care when installing retainers and scraper. Retainers and scrapers are under spring tension and can act as projectiles when released and could cause severe eye injury.

- 5 Install new preformed packing (9) and new scraper (8) in nut (4).
- 6 Install nut (4) on piston (5).
- 7 Install new preformed packing (7) and two new retainers (6) on piston (5).
- 8 Coat surface of piston (5) with grease and install piston (5) in cylinder (1).
- 9 Apply antiseize tape to threads of bleeder plug (2).
- 10 Install bleeder body (3) and bleeder plug (2) in cylinder (1).
- 11 Screw nut (4) in cylinder (1). Torque nut to 180-220 lb-ft (244-298 N·m).

Section II. TRACK IDLERS AND BRACKETS - CONTINUED

8-2 TRACK ADJUSTER CYLINDER ASSEMBLY - CONTINUED

b. Assembly - Continued

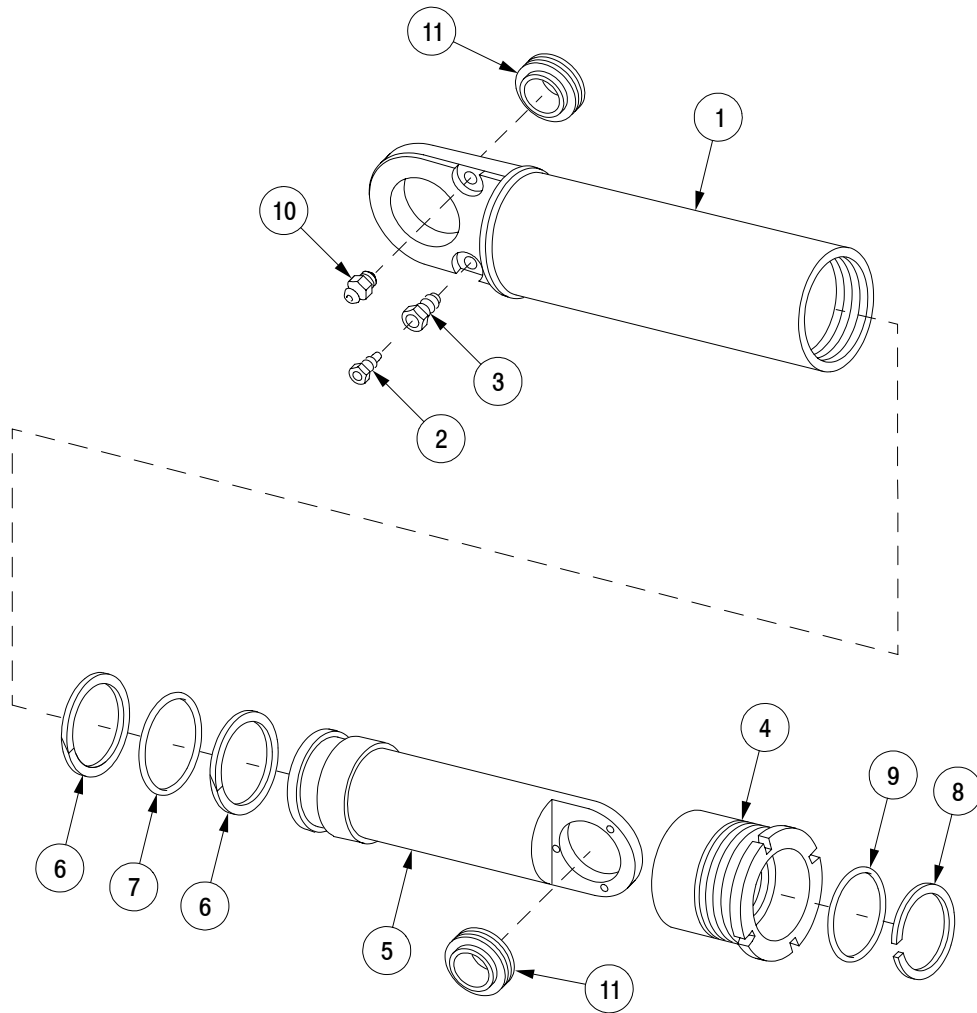

13ph018m

NOTE

FOLLOW-ON MAINTENANCE:

Install track adjuster
(TM 9-2350-314-20-1-2)

CHAPTER 9 STEERING

GENERAL

This chapter illustrates and defines the direct support procedures for removal and installation of steering control linkage components.

<u>CONTENTS</u>	<u>Page</u>
REMOTE LEVER (STEERING)	9-2



REMOTE LEVER (STEERING).

This task covers: a. Removal b. Installation

INITIAL SETUP

Tools

General mechanic's tool kit
(SC 5180-90-N26)
Snapping pliers (item 33, Appx F)

Materials/Parts

Retaining ring (item 45, Appx E)

Equipment Conditions

Tracks blocked
(TM 9-2350-314-10)
Transmission access doors opened
(TM 9-2350-314-10)

References

TM 9-2350-314-10
TM 9-2350-314-20-1-2

a. Removal.

WARNING

Track must be blocked so that the vehicle will not roll out of control. When remote lever (steering) is disconnected, vehicle is without brakes. Failure to securely block vehicle tracks may result in severe injury to personnel or equipment damage.

- 1 Remove quick-release pin (1) from lever (2).
- 2 Remove rod assembly (3) from lever (2).

WARNING

Use care when removing snap and retaining rings. Snap and retaining rings are under spring tension and can act as projectiles when released and could cause severe eye injury.

- 3 Remove retaining ring (4) and lever (2) from transmission shaft (5). Discard retaining ring.

REMOTE LEVER (STEERING) - CONTINUED

b. Installation.**WARNING**

Use care when installing snap and retaining rings. Snap and retaining rings are under spring tension and can act as projectiles when released and could cause severe eye injury.

- 1 Install lever (2) and new retaining ring (4) on transmission shaft (5).
- 2 Install rod assembly (3) in lever (2) with quick-release pin (1).

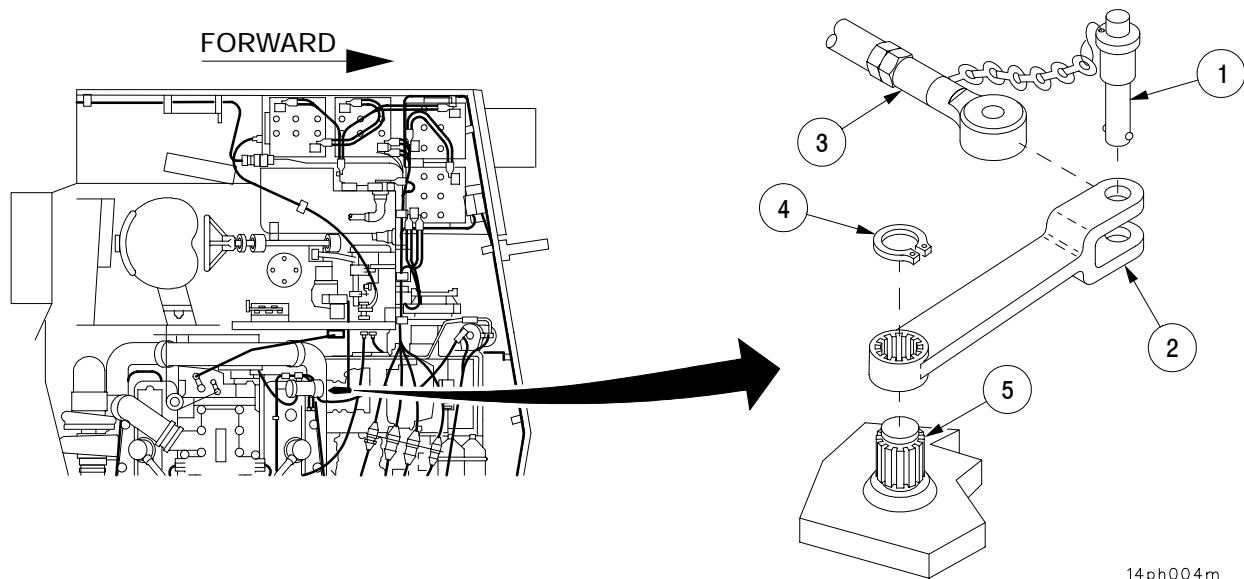
**NOTE****FOLLOW-ON MAINTENANCE:**

- Adjust steering control linkage
(TM 9-2350-314-20-1-2)
- Close and secure transmission access doors
(TM 9-2350-314-10)
- Unblock tracks
(TM 9-2350-314-10)

CHAPTER 10

BODY, CAB, HOOD, AND HULL

GENERAL

This chapter illustrates and defines direct support procedures for removal, disassembly, assembly, and installation of hull-related components.

<u>CONTENTS</u>	<u>Page</u>
Section I. BODY, CAB, HOOD, AND HULL ASSEMBLIES	
10-1 ENGINE COMPARTMENT BULKHEAD INSULATION AND SHIELDS	10-2
10-2 RACE RING LOCATING PIN	10-10
Section II. DRIVER'S HATCH AND PERISCOPES	
10-3 DRIVER'S HATCH HOUSING ASSEMBLY	10-11
Section III. HULL REAR DOOR	
10-4 HULL REAR DOOR REPLACEMENT	10-12

Section I. BODY, CAB, HOOD, AND HULL ASSEMBLIES

10-1 ENGINE COMPARTMENT BULKHEAD INSULATION AND SHIELDS.

This task covers: a. Removal b. Installation

INITIAL SETUP

Tools

General mechanic's tool kit
(SC 5180-90-N26)
Torque wrench (item 57, Appx F)
Wire brush (item 8, Appx F)

Materials/Parts

Adhesive (item 1, Appx B)
Dry-cleaning solvent (item 29, Appx B)
Sealing compound (item 26, Appx B)
Acid swabbing brush (item 6, Appx B)

Equipment Conditions

Vehicle parked on level ground and blocked
(TM 9-2350-314-10)
Fuel tanks removed (para 5-2)
Bulkhead wall connections mounted through
insulation and shield removed
(TM 9-2350-314-20-1-1)
Personnel heater exhaust tube removed
(TM 9-2350-314-20-1-2)
Air cleaner ducts and hoses removed
(TM 9-2350-314-20-1-1)
Engine mount base assembly lower bar removed
(TM 9-2350-314-20-1-1)

Personnel Required

Three

References

TM 9-2350-314-10
TM 9-2350-314-20-1-1
TM 9-2350-314-20-1-2

Section I. BODY, CAB, HOOD, AND HULL ASSEMBLIES - CONTINUED

10-1 ENGINE COMPARTMENT BULKHEAD INSULATION AND SHIELDS - CONTINUED

a. Removal - Continued

- 1 Remove seven screws (1) and seven flat washers (2) from shield (3).
- 2 Remove five screws (4), five flat washers (5), and bracket (6).
- 3 Remove screw (7) and flat washer (8) from access cover (9).
- 4 Remove four screws (10) and four flat washers (11) from access cover (9).
- 5 Remove nine screws (12), nine flat washers (13), shields (3) and (14), and access cover (9).

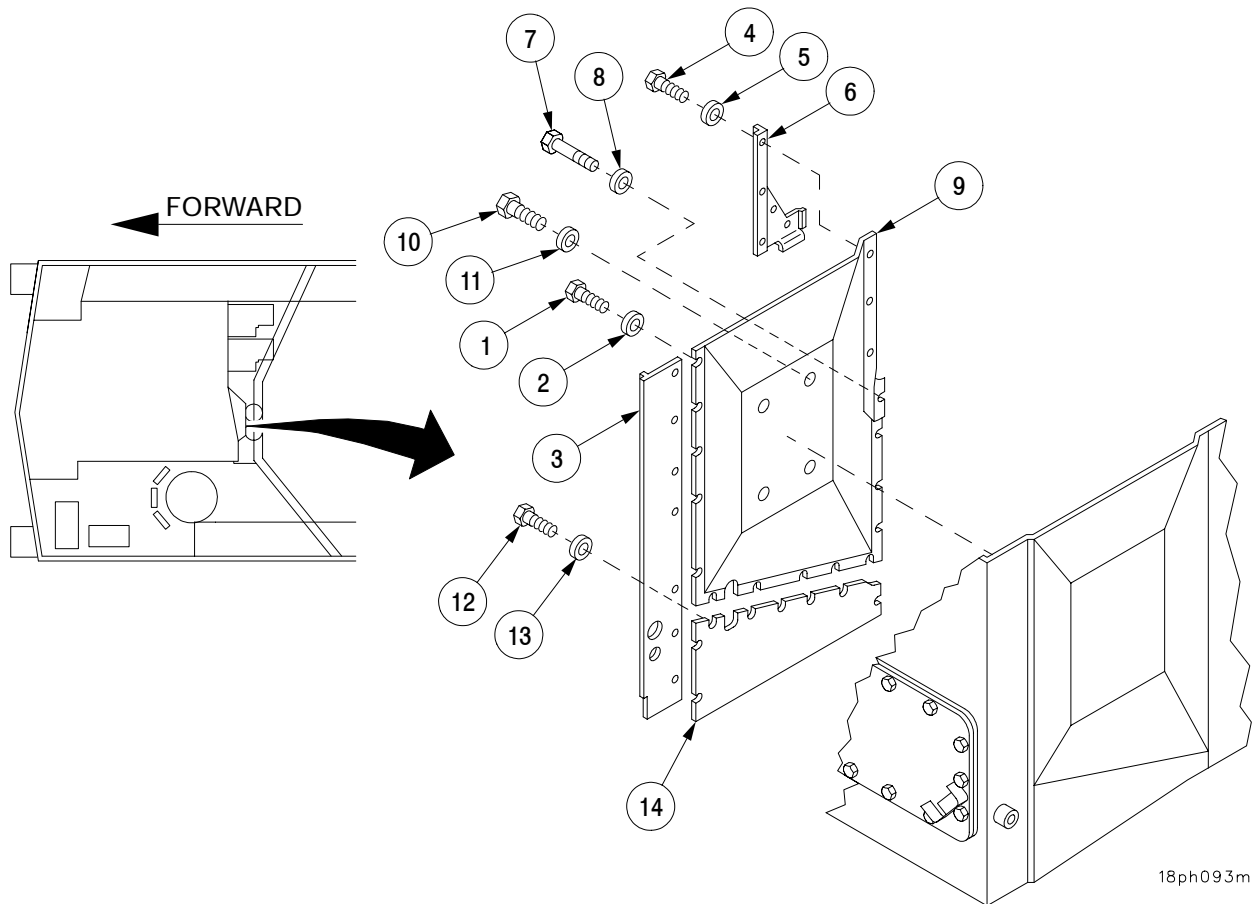

Section I. BODY, CAB, HOOD, AND HULL ASSEMBLIES - CONTINUED

10-1 ENGINE COMPARTMENT BULKHEAD INSULATION AND SHIELDS - CONTINUED

a. Removal - Continued

- 6 Remove two screws (15), two flat washers (16), four screws (17), four flat washers (18), and shield (19) from bulkhead (20).
- 7 Remove 12 screws (21), 12 flat washers (22), and two grilles (23) from shield (19).
- 8 Remove five screws (24), five flat washers (25), eight screws (26), eight flat washers (27), and shield (28).

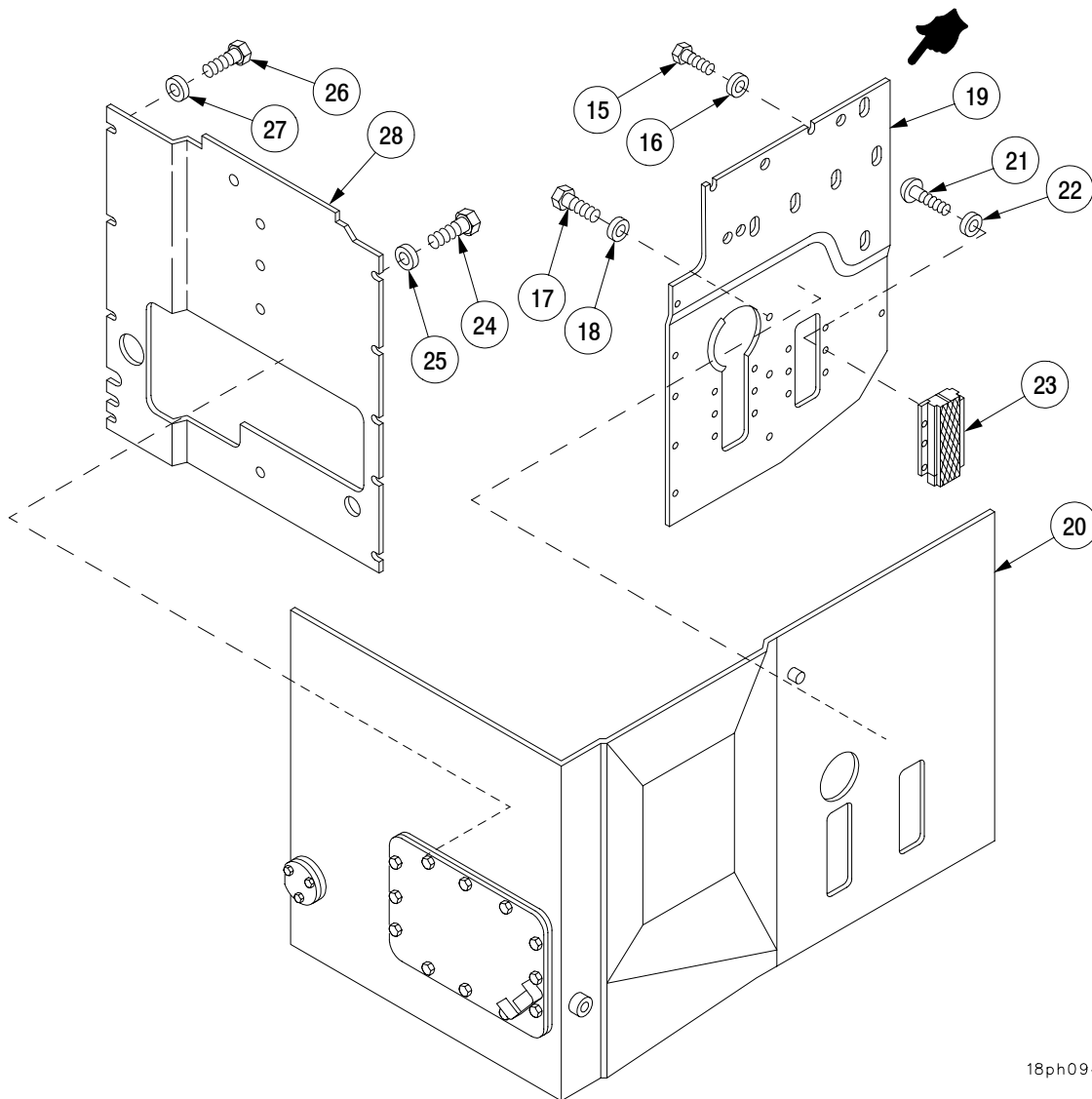

18ph094m

Section I. BODY, CAB, HOOD, AND HULL ASSEMBLIES - CONTINUED

10-1 ENGINE COMPARTMENT BULKHEAD INSULATION AND SHIELDS - CONTINUED

a. Removal - Continued

- 9 Remove cemented insulation pieces (29, 30, 31, 32, 33, 34, 35, 36, 37, 38, 39, 40, and 41) from bulkhead (20). Discard insulation pieces.

WARNING

Dry-cleaning solvent (P-D-680), used to clean parts, is toxic and flammable. Wear protective goggles and gloves and use only in a well-ventilated area. Avoid contact with skin, eyes, and clothes. Do not breathe vapors. Do not use near open flame or excessive heat. Do not smoke when using solvent. Failure to do so could cause **SERIOUS INJURY**. If you become dizzy while using dry-cleaning solvent, get fresh air immediately, and if necessary, get medical attention. If contact with skin or clothes is made, flush thoroughly with water. If the solvent contacts your eyes, wash them with water immediately and obtain medical aid (FM 21-11).

- 10 Thoroughly clean and dry seal channel and insulation mounting surfaces. Be sure to remove all seal particles using dry-cleaning solvent and wire brush.

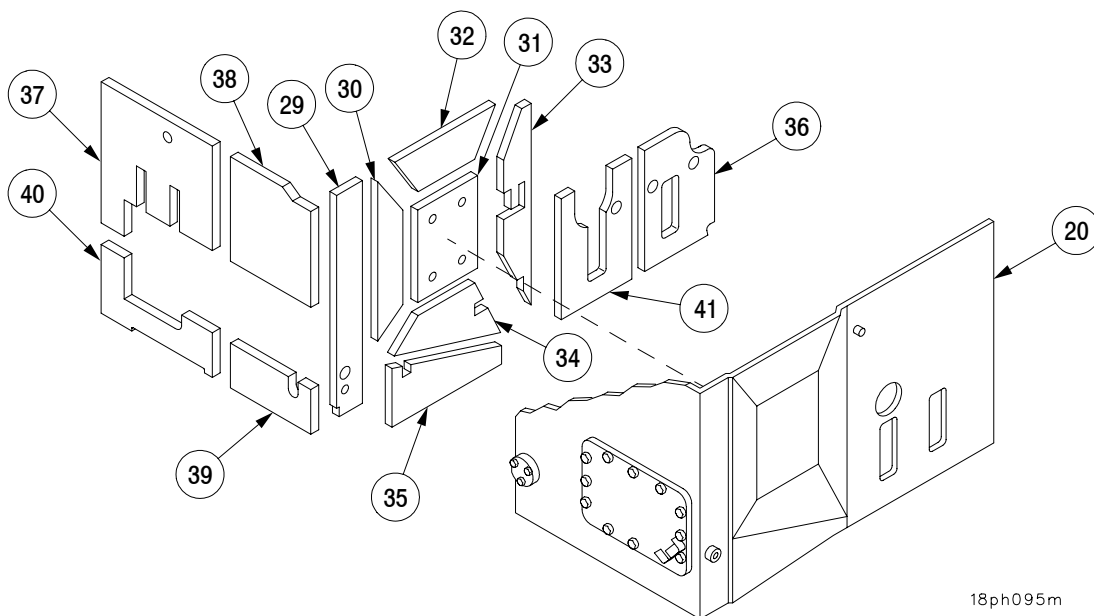

18ph095m

Section I. BODY, CAB, HOOD, AND HULL ASSEMBLIES - CONTINUED

10-1 ENGINE COMPARTMENT BULKHEAD INSULATION AND SHIELDS - CONTINUED

b. Installation.

- 1 Apply adhesive to new insulation pieces (29, 30, 31, 32, 33, 34, 35, 36, 37, 38, 39, 40, and 41) using acid brush.
- 2 Install new insulation pieces (29, 30, 31, 32, 33, 34, 35, 36, 37, 38, 39, 40, and 41) to bulkhead (20).

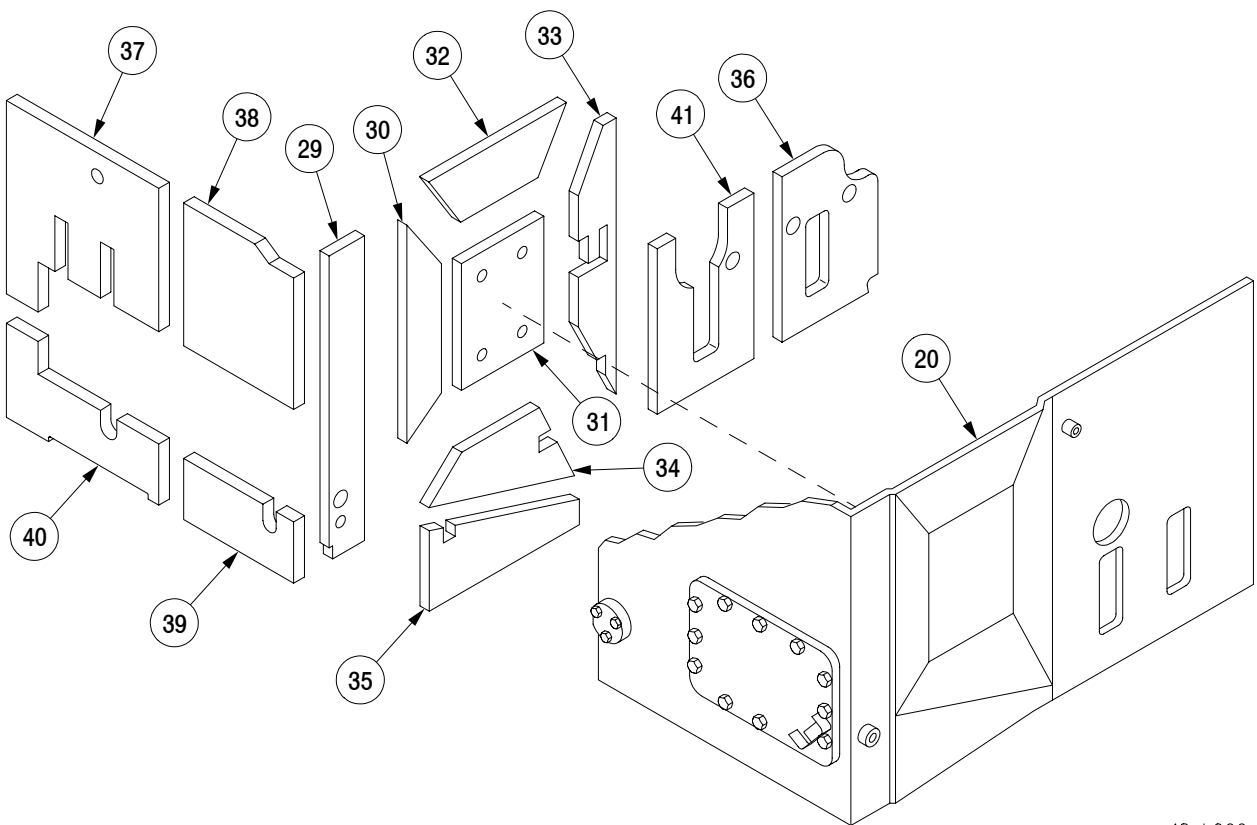

18ph099m

Section I. BODY, CAB, HOOD, AND HULL ASSEMBLIES - CONTINUED

10-1 ENGINE COMPARTMENT BULKHEAD INSULATION AND SHIELDS - CONTINUED

b. Installation - Continued**NOTE**

Apply sealing compound to all screws prior to installation.

- 3 Install shield (28) on bulkhead (20) with eight screws (26), eight flat washers (27), five screws (24), and five flat washers (25). Torque screws to 21-25 lb-ft (28-33 N-m).

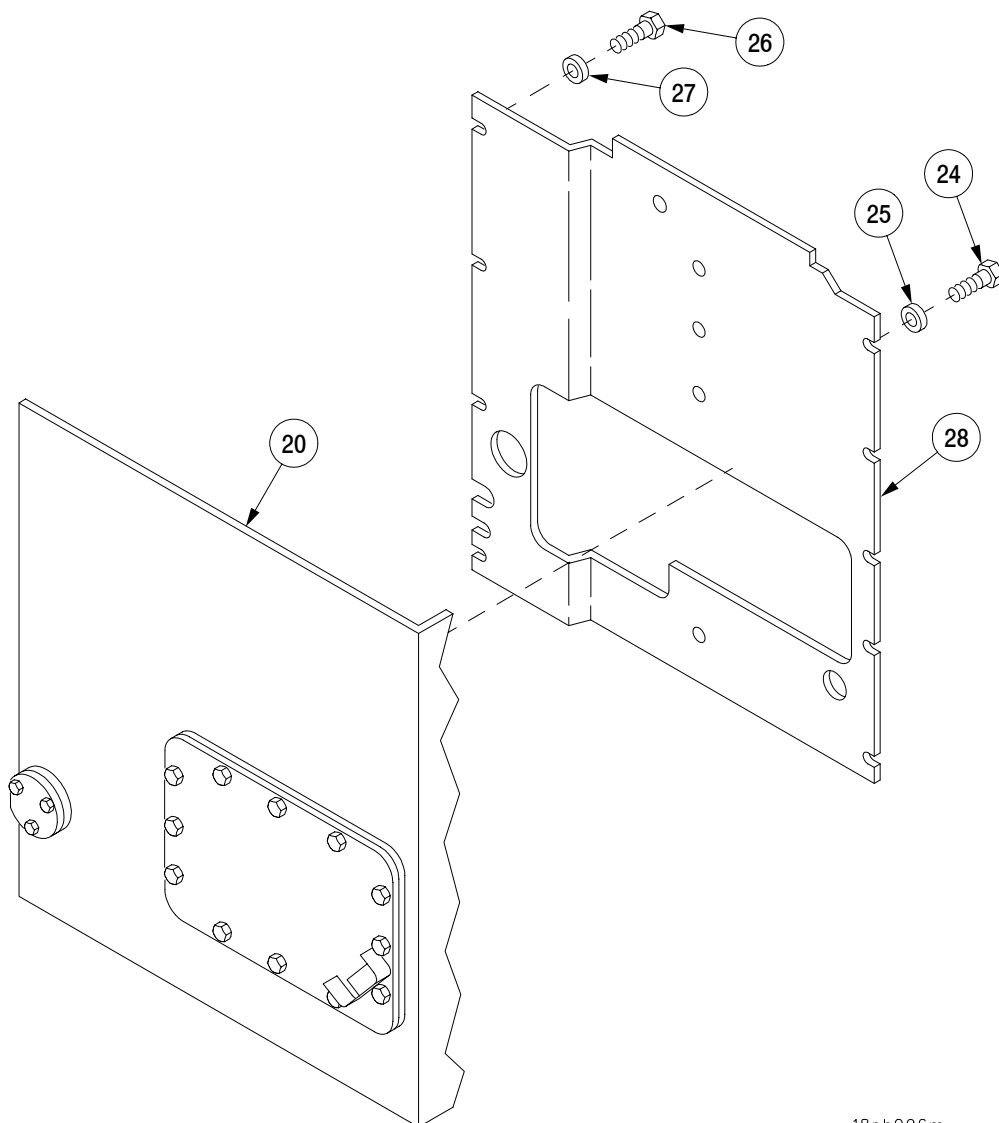

18ph096m

Section I. BODY, CAB, HOOD, AND HULL ASSEMBLIES - CONTINUED

10-1 ENGINE COMPARTMENT BULKHEAD INSULATION AND SHIELDS - CONTINUED

b. Installation - Continued

- 4 Install two grilles (23) on shield (19) with 12 screws (21) and 12 flat washers (22).
- 5 Install shield (19) on bulkhead (20) with two screws (15), two flat washers (16), four screws (17), and four flat washers (18). Torque screws to 9-11 lb-ft (12-14 N-m).

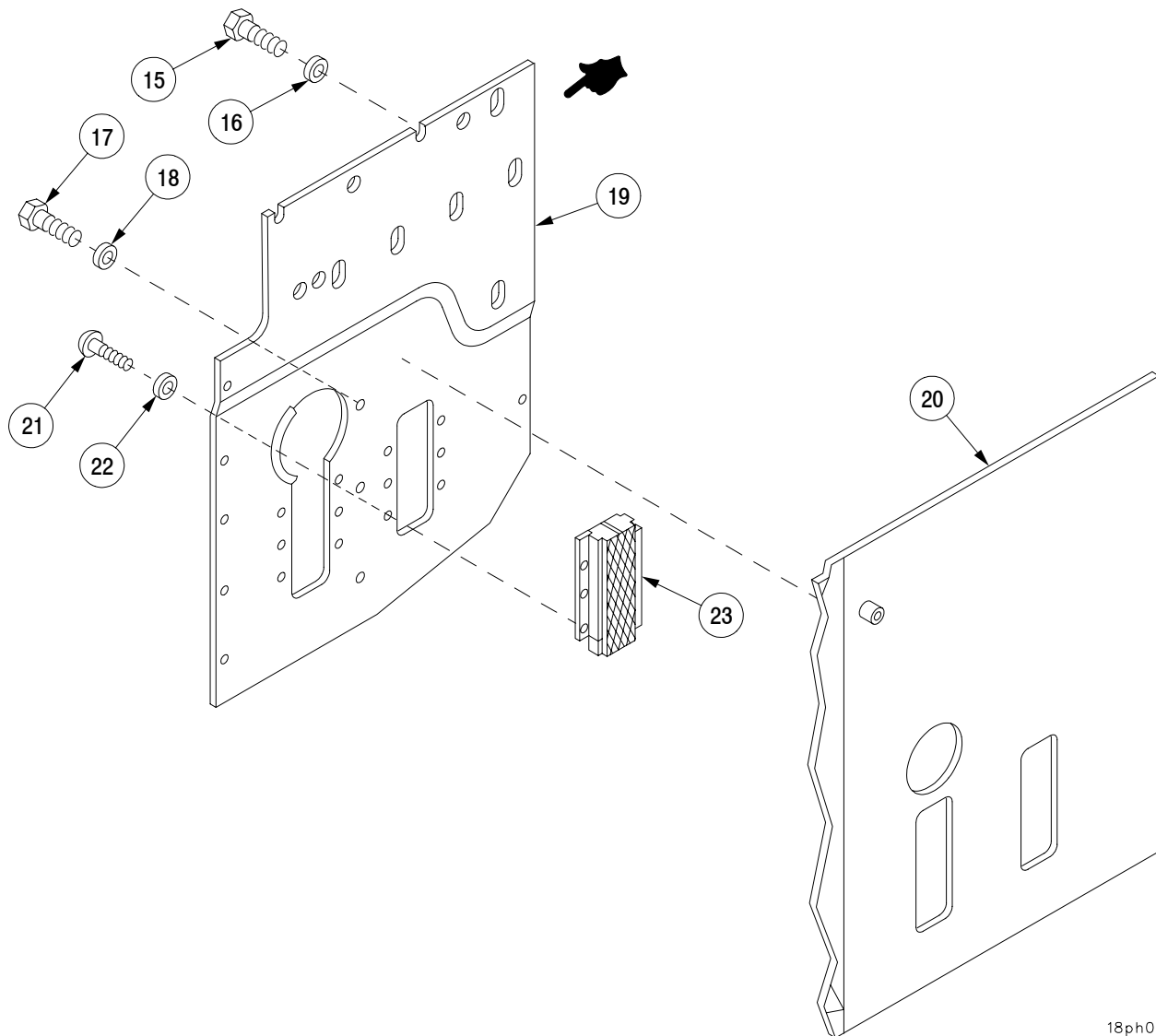

18ph097m

Section I. BODY, CAB, HOOD, AND HULL ASSEMBLIES - CONTINUED

10-1 ENGINE COMPARTMENT BULKHEAD INSULATION AND SHIELDS - CONTINUED

b. Installation - Continued

- 6 Install shields (3) and (14) and access cover (9) on bulkhead (20) with nine screws (12) and nine flat washers (13). Do not tighten screws.
- 7 Install bracket (6) on bulkhead (20) with five screws (4) and five flat washers (5). Do not tighten screws.
- 8 Install four screws (10) and four flat washers (11) in access cover (9). Do not tighten screws.
- 9 Install screw (7) and flat washer (8) in access cover (9). Do not tighten screws.
- 10 Install seven screws (1) and seven flat washers (2) in shield (3). Do not tighten screws.
- 11 Torque screws (1, 4, 7, 10, and 12) to 9-11 lb-ft (12-14 N·m).

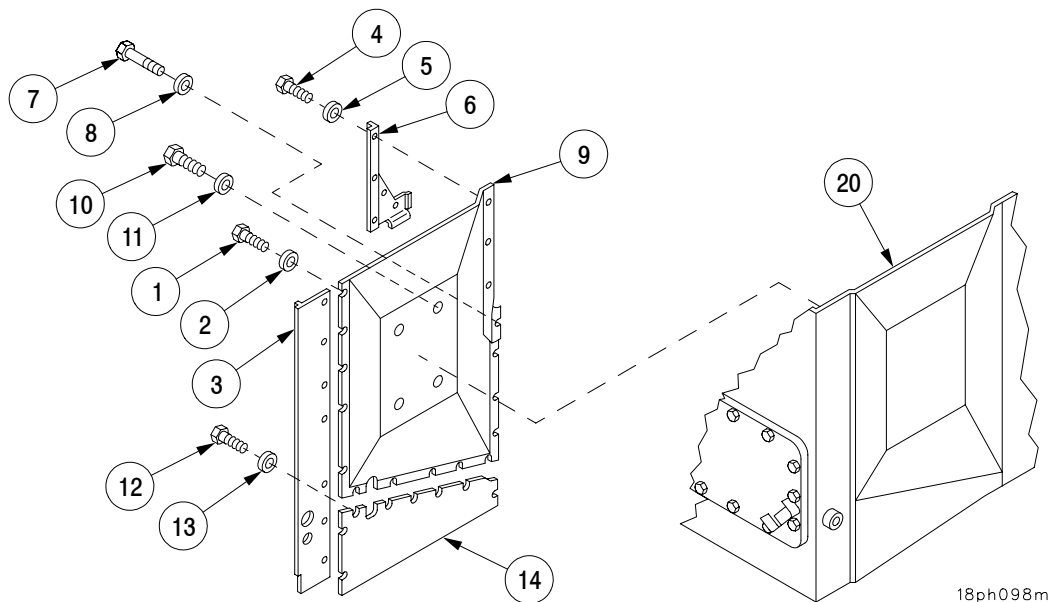
NOTE
FOLLOW-ON MAINTENANCE:

- Install engine mount base assembly bar
(TM 9-2350-314-20-1-1)
- Install air cleaner ducts and hoses
(TM 9-2350-314-20-1-1)
- Install personnel heater exhaust tube
(TM 9-2350-314-20-1-2)
- Install bulkhead wall connections
(TM 9-2350-314-20-1-1)
- Install fuel tanks (para 5-2)
- Unblock tracks (TM 9-2350-314-10)

Section I. BODY, CAB, HOOD, AND HULL ASSEMBLIES - CONTINUED

10-2 RACE RING LOCATING PIN.

This task covers: a. Removal b. Installation

INITIAL SETUP

Tools

General mechanic's tool kit
(SC 5180-90-N26)

Equipment Conditions

Cab removed
(TM 9-2350-314-34-2)

References

TM 9-2350-314-34-2

a. Removal.

Remove pin (1) from hull (2).

b. Installation.

Install pin (1) on hull (2).

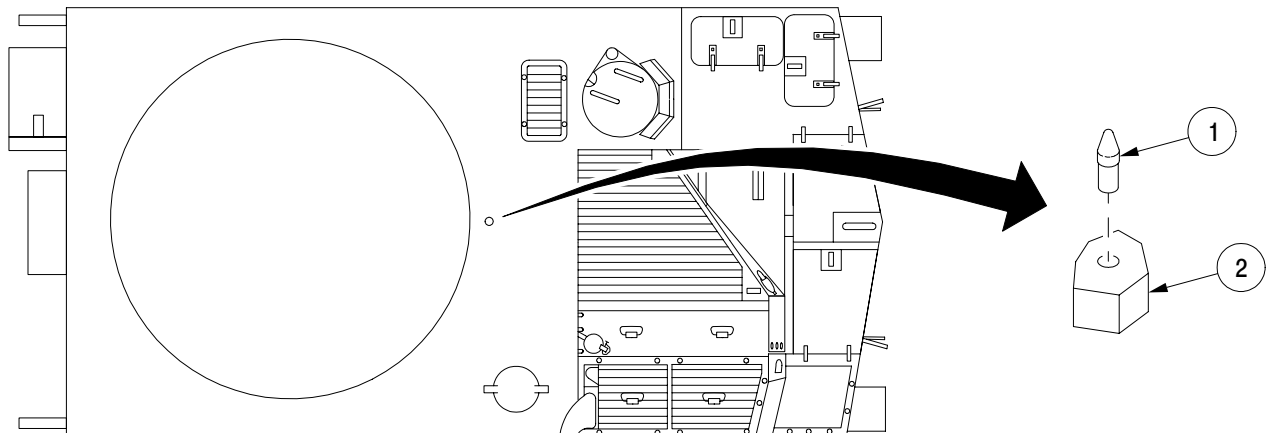

18ph100m

NOTE

FOLLOW-ON MAINTENANCE:

Install cab (TM 9-2350-314-34-2)

Section II. DRIVER'S HATCH AND PERISCOPE

10-3 DRIVER'S HATCH HOUSING ASSEMBLY.

This task covers: a. Disassembly b. Assembly

INITIAL SETUP

Tools

General mechanic's tool kit
(SC 5180-90-N26)
Arbor press (item 5, Appx F)

Equipment Conditions

Driver's hatch housing removed
(TM 9-2350-314-20-1-2)

References

TM 9-2350-314-20-1-2

a. Disassembly.

Remove spacer plate (1), ball bearing (2), spacer ring (3), and two bearing sleeves (4) from housing (5).

b. Assembly.

Install two bearing sleeves (4), spacer ring (3), ball bearing (2), and spacer plate (1) in housing (5).

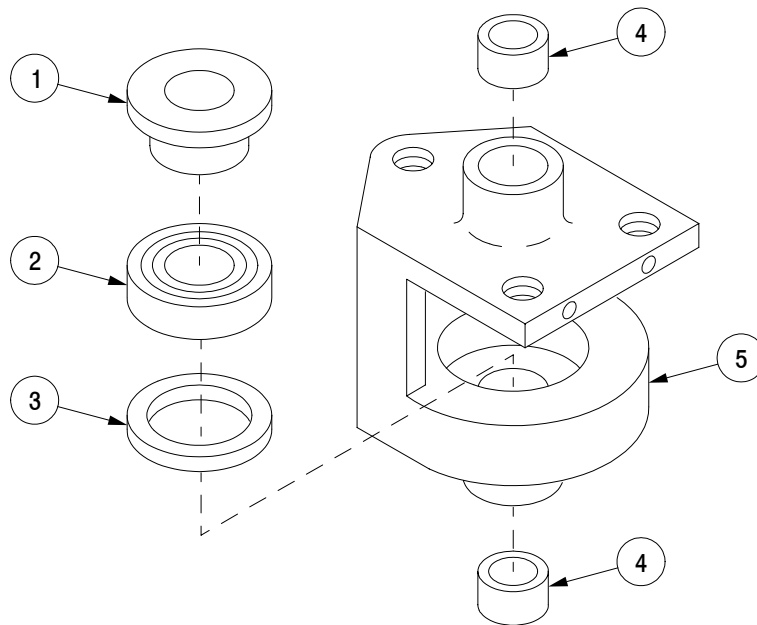

18ph101m

NOTE

FOLLOW-ON MAINTENANCE:

Install drivers hatch housing
(TM 9-2350-314-20-1-2)

Section III. HULL REAR DOOR

10-4 HULL REAR DOOR

This task covers: Repair/Replacement

INITIAL SETUP

Tools

General mechanic's tool kit
 (SC 5180-90-N26)
 Drill bit (item 15.1, Appx F)
 Drill (item 16, Appx F)
 Drill set (item 17, Appx F)
 Thread set (item 50.1, Appx F)
 Welding shop (item 54, Appx F)

Equipment Conditions

Hull rear door removed
 (TM 9-2350-314-20-1-2)

References

TM 9-2350-314-20-1-2

Repair/Replacement

- 1 Locate, drill and tap 10 holes (1) as shown.
- 2 Install 10 inserts (2) as shown.
- 3 Locate and weld two blocks (3) as shown.
- 4 Locate and weld bracket (4) as shown.

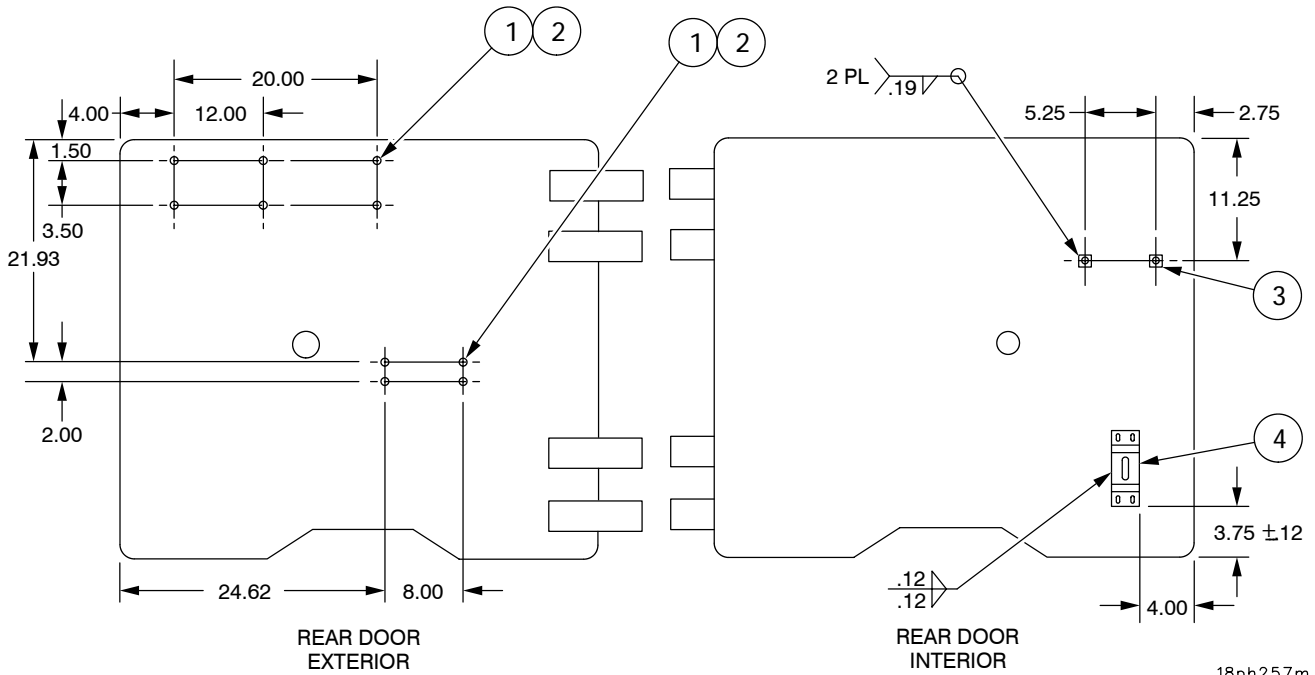

NOTE

FOLLOW-ON MAINTENANCE:
 Install hull rear door (TM 9-2350-314-20-1-2)

CHAPTER 11 BILGE PUMP

GENERAL

This chapter illustrates and describes the direct support procedure for disassembly, inspection, and assembly of the bilge pump.

<u>CONTENTS</u>	<u>Page</u>
BILGE PUMP	11-2

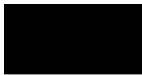

BILGE PUMP.

This task covers: a. Disassembly b. Inspection c. Assembly

INITIAL SETUP

Tools

Fuel and electric automotive tool kit
(SC 5180-95-B08)
Multimeter (item 31, Appx F)
Soldering gun (item 49, Appx F)
Spanner wrench (item 44, Appx F)
Growler (item 20, Appx F)
Snapping pliers (item 33 , Appx F)
Puller, common mechanical (item 36, Appx F)
Pliers, wire twisting (item 34, Appx F)

Equipment Conditions

Bilge pump removed
(TM 9-2350-314-20-1-2)

References

TB SIG 222
TM 9-2350-314-20-1-2

Materials/Parts

Lockwashers (8) (item 13, Appx E)
Lockwasher (item 74, Appx E)
Lockwashers (12) (item 73, Appx E)
Lockwashers (4) (item 70, Appx E)
Lockwire (AR) (item 48, Appx E)
Parts kit (item 24, Appx E)
Parts kit (item 87 , Appx E)
Solder (item 28, Appx B)
Soldering flux (item 10, Appx B)

BILGE PUMP - CONTINUED

a. Disassembly.

- 1 Remove four brush caps (1), four preformed packings (2), and four brushes (3). Discard preformed packings and brushes.
- 2 Remove four screws (4), four lockwashers (5), and inlet screen (6). Discard lockwashers.
- 3 Remove four bolts (7), four lockwashers (8), and impeller cover (9). Discard lockwashers.
- 4 Remove round nut (10), lockwasher (11), and impeller (12). Discard lockwasher.
- 5 Remove impeller housing (13) and key (14).

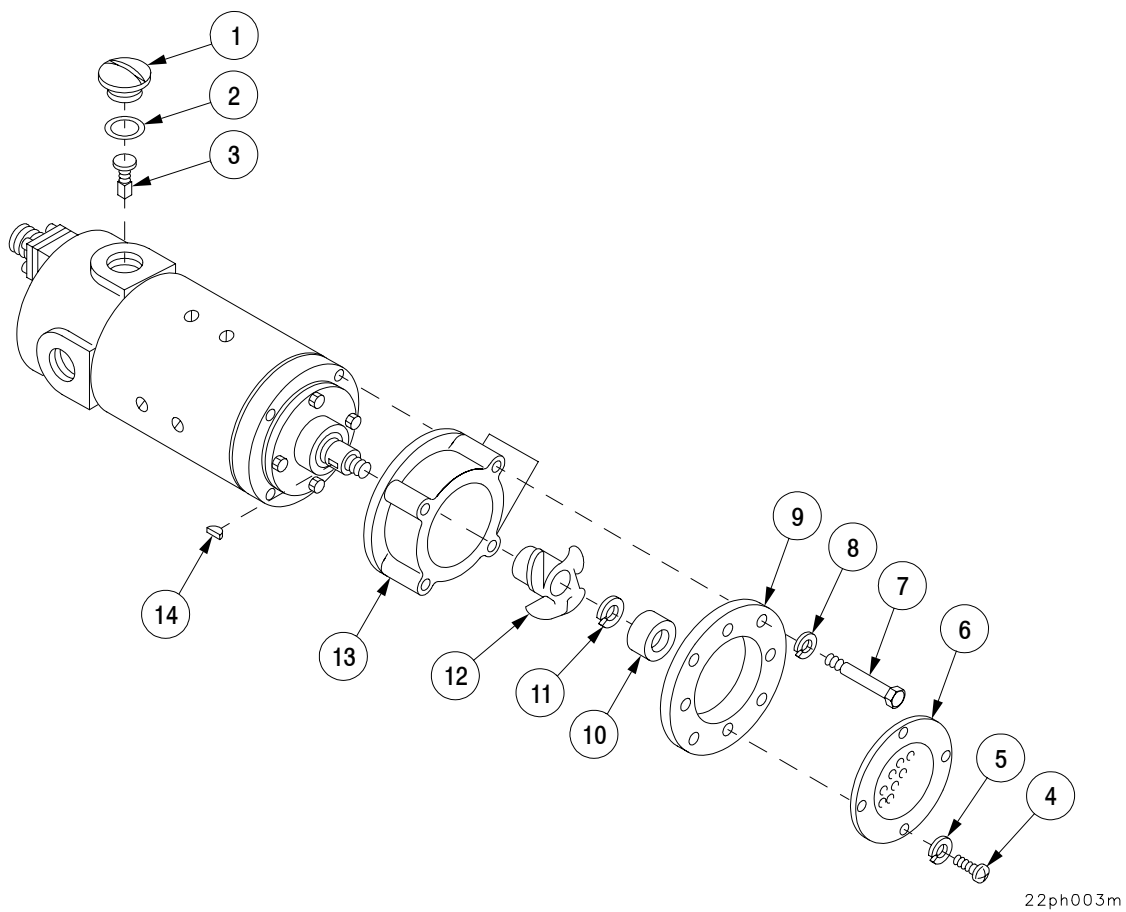

BILGE PUMP - CONTINUED

a. Disassembly - Continued

- 6 Remove four screws (15), four lockwashers (16), seal cover (17), and gasket (18). Discard lockwashers and gasket.
- 7 Remove two seals (19), and seal (20) from seal cover (17). Discard seals.
- 8 Remove four nuts (21), four lockwashers (22), four flat washers (23), and four gaskets (24). Discard lockwashers and gaskets.
- 9 Remove drive end assembly including armature (25), four insulation sleeves (26), and gasket (27). Remove four studs (28) from drive end assembly (25). Discard gasket.

NOTE

Note depth of four studs in drive end assembly during removal to ensure studs are not installed beyond that depth during assembly.

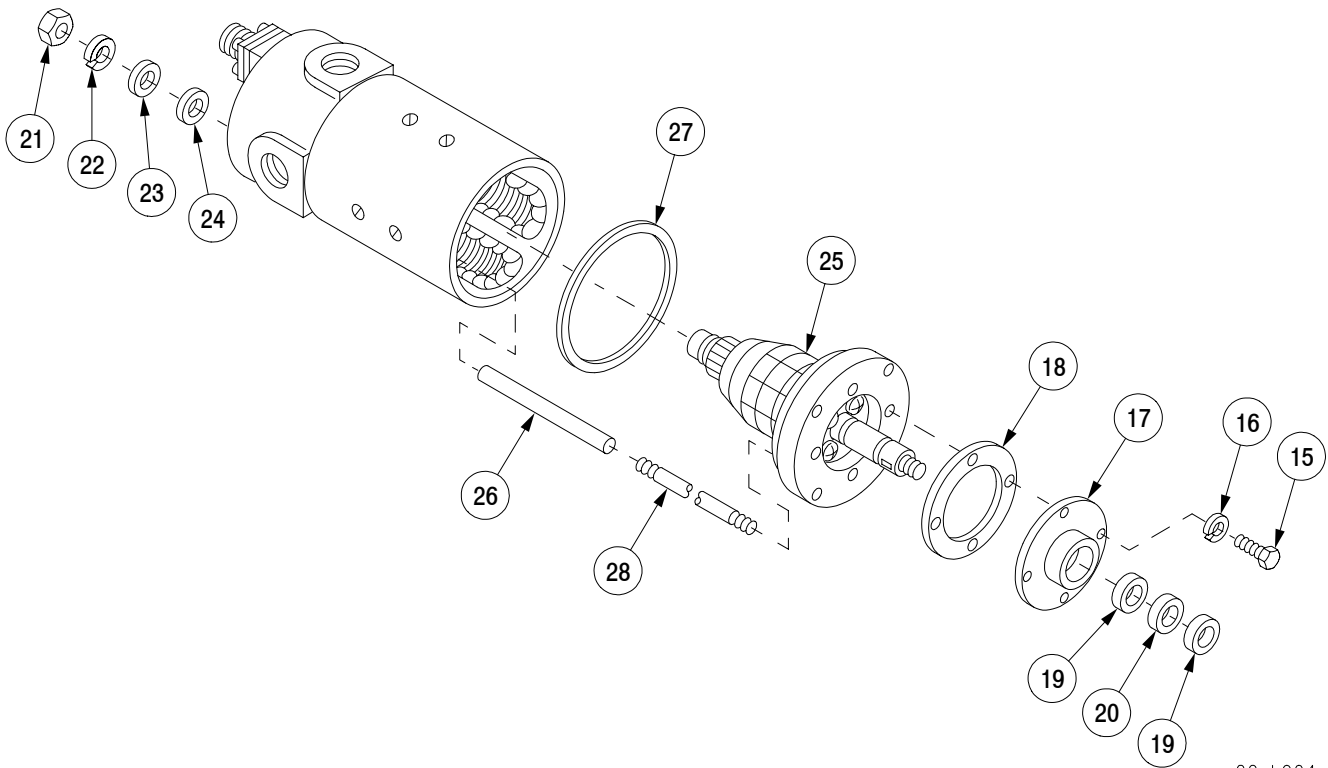

22ph004m

BILGE PUMP - CONTINUED

a. Disassembly - Continued

WARNING

Use care when removing snap and retaining rings. Snap and retaining rings are under spring tension and can act as projectiles when released and could cause severe eye injury.

- 10 Remove lockwire (29), four screws (30), four lockwashers (31), retainer plate (32), and snapping (33). Discard lockwire, snapping, and lockwashers.
- 11 Remove bearing (34), drive end (35), and bearing (36) from armature (37). Discard bearings.

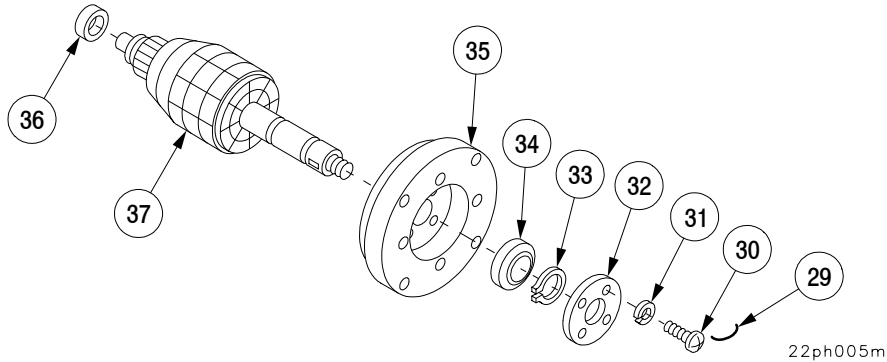

- 12 Remove four screws (38) and four lockwashers (39) securing capacitor (40). Discard lockwashers.
- 13 Pull capacitor (40), two gaskets (41), and spacer (42) from end bell (43). Discard gaskets.

NOTE

Before proceeding, see detailed instructions on soldering and solder (TB SIG 222).

- 14 Unsolder wire (44) from capacitor (40) using soldering gun.

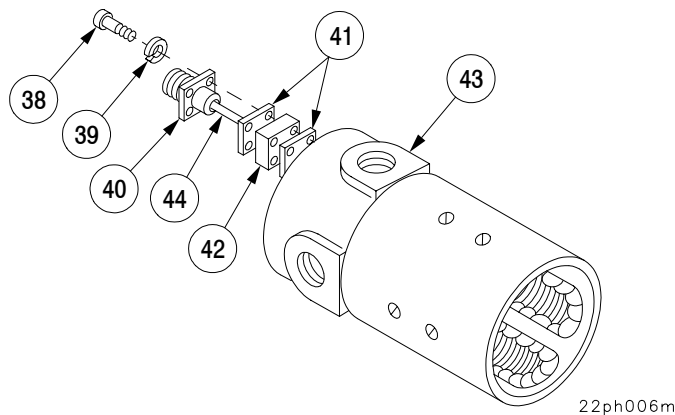

BILGE PUMP - CONTINUED

a. Disassembly - Continued

- 15 Remove capacitor (40), two gaskets (41), and spacer (42). Discard gaskets.
- 16 Pull stator assembly (45) away from end bell (43).
- 17 Remove screw (46), lockwasher (47), and wire (48) from inside of end bell (43). Discard lockwasher.
- 18 Remove insulation sleeves (49) from electrical wires (44 and 48) only if necessary.
- 19 Remove stator assembly (45) and gasket (50). Discard gasket.

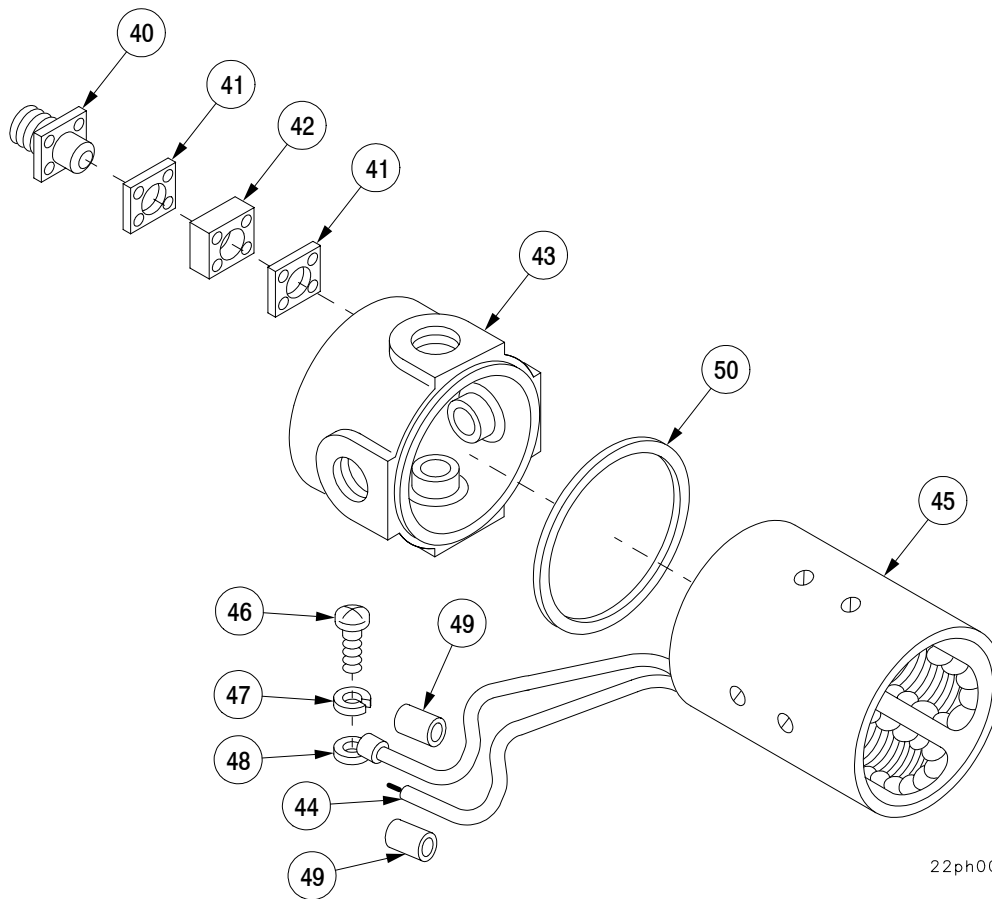

22ph007m

BILGE PUMP - CONTINUED

b. Inspection.

WARNING

- Compressed air used for cleaning purposes will not exceed 30 psi (207 kpa). Use only with effective chip guarding and personal protective equipment (goggles/shield, gloves, etc.).
- Air pressure may create airborne debris. Use eye protection or injury to personnel may result.

- 1 Clean and inspect inlet screen (6). Blow out mesh with compressed air. Replace if torn.
- 2 Inspect impeller (12) for damage and defects. Smooth out nicks and burrs with soft stone or fine mill file. Replace if damaged or defective.
- 3 Inspect impeller housing (13) for cracks, warped mating surface, or other damage. Replace if damaged or defective.
- 4 Inspect key (14) for damage. Replace if necessary.
- 5 Inspect seal cover (17) for cracks, warped mating surface, and other damage. Replace if damaged or defective.
- 6 Inspect insulation sleeves (26 and 49) if frayed or torn, replace as necessary.
- 7 Inspect drive end (35) for cracks, defects, and warped mating surfaces. Replace if defective.
- 8 Test armature (37) on growler. Replace if defective.
- 9 Test continuity of field coils (51) using multimeter on wires (44 and 48). If defective, replace stator assembly (45).
- 10 Test capacitor (40) for continuity using multimeter. If resistance value is shown on multimeter, replace capacitor (40).

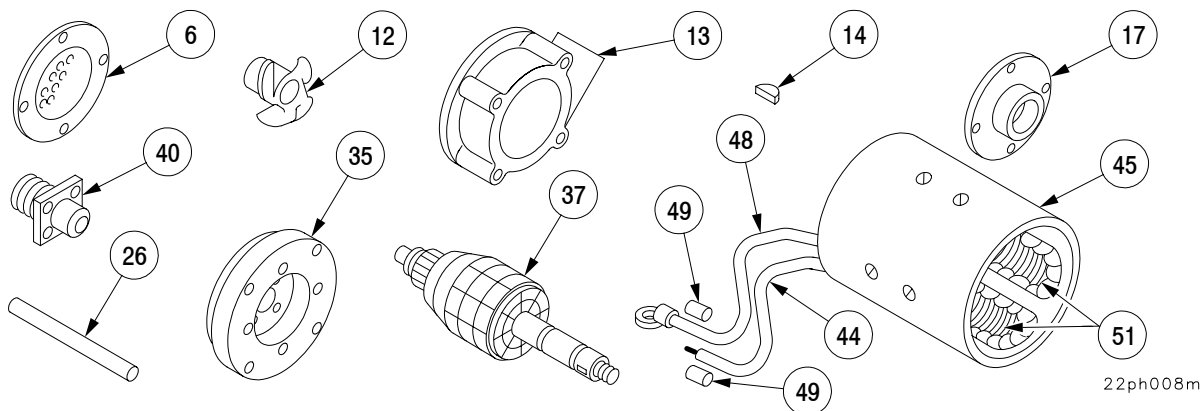

BILGE PUMP - CONTINUED

c. Assembly.

- 1 Install sleeves (49) over wires (44 and 48) if removed.
- 2 Insert two wires (44 and 48) through new gasket (50) and attach wire (48) to inside of end bell (43) with screw (46) and new lockwasher (47).
- 3 Install stator assembly (45) and new gasket (50) on end bell (43) making sure wire (44) goes through opening of end bell (43).
- 4 Assemble capacitor (40), two new gaskets (41), and spacer (42).

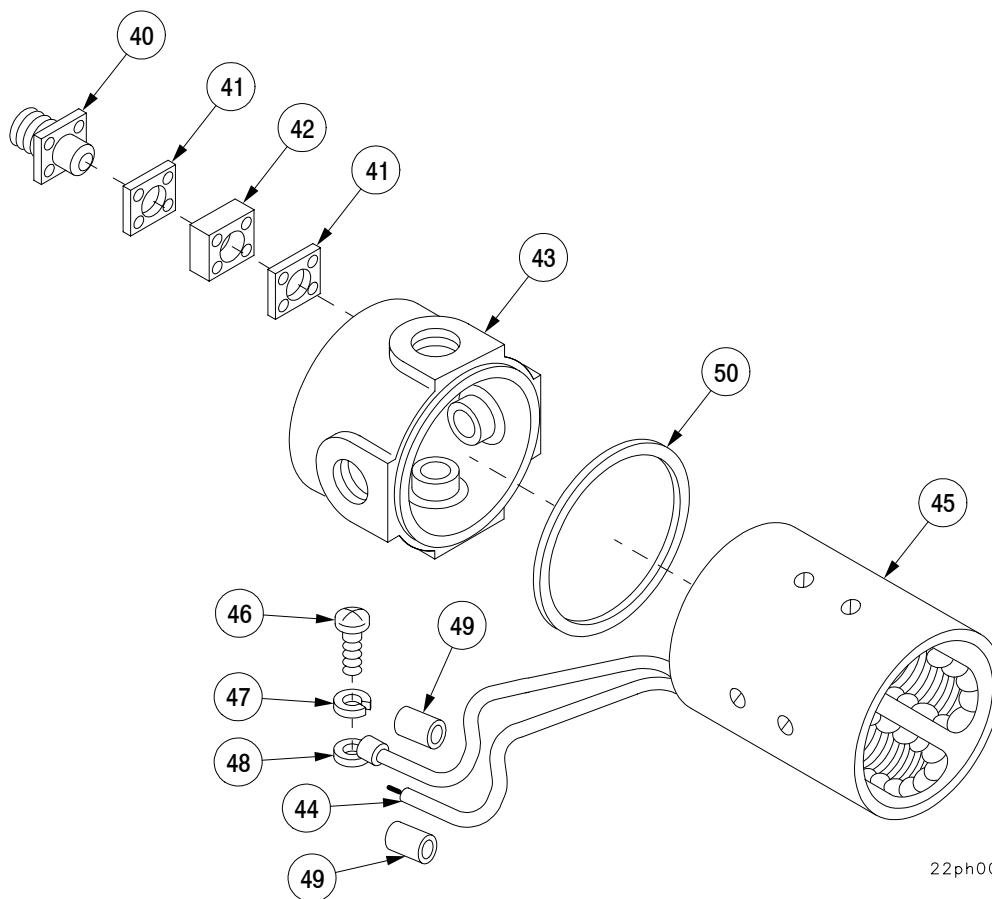

22ph007m

BILGE PUMP - CONTINUED

c. Assembly - Continued

NOTE

Before proceeding, see detailed instructions on soldering and solder (TB SIG 222).

- 5 Solder wire (44) to capacitor (40) using solder flux and soldering gun.
- 6 Install capacitor (40), two new gaskets (41), and spacer (42) on end bell (43) with four screws (38) and four new lockwashers (39).

WARNING

Use care when installing snap and retaining rings. Snap and retaining rings are under spring tension and can act as projectiles when released and could cause severe eye injury.

NOTE

Bearings are different sizes. Make sure bearings are installed at location as shown. Do not reverse installation of bearings.

- 7 Install drive end (35), new bearing (34), and new snapping (33) on armature (37).
- 8 Install retainer plate (32) with four screws (30), four new lockwashers (31), and new lockwire (29).
- 9 Install new bearing (36) on armature (37).

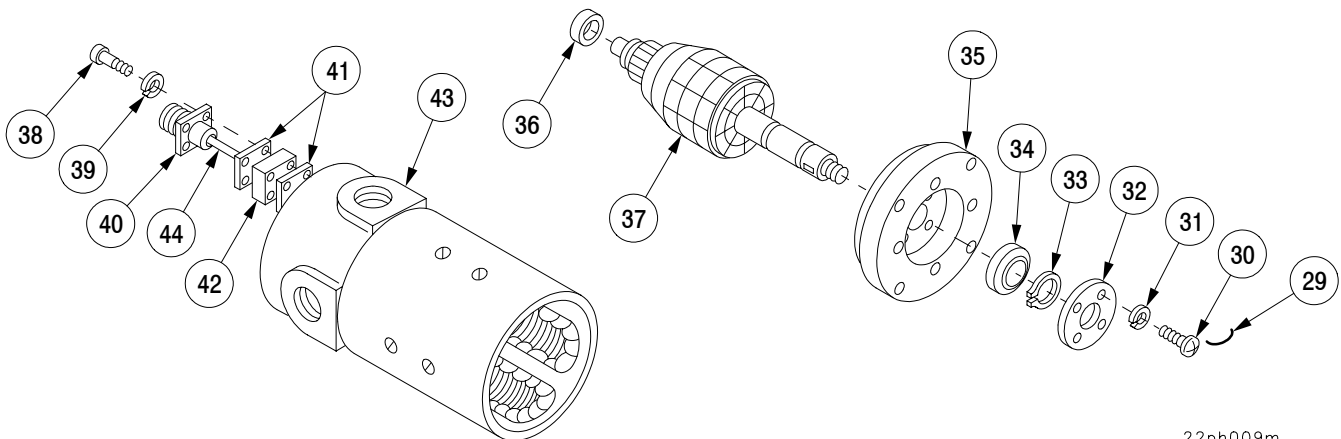

22ph009m

BILGE PUMP - CONTINUED

c. Assembly - Continued

- 10 Install four studs (28) and four insulation sleeves (26) on drive end assembly (25).
- 11 Install drive end assembly (25) and new gasket (27) in stator assembly (45) and secure with four new gaskets (24), four flat washers (23), four new lockwashers (22), and four nuts (21).
- 12 Install two new seals (19) and new seal (20) in seal cover (17).
- 13 Install seal cover (17) with new gasket (18), four screws (15), and four new lockwashers (16).

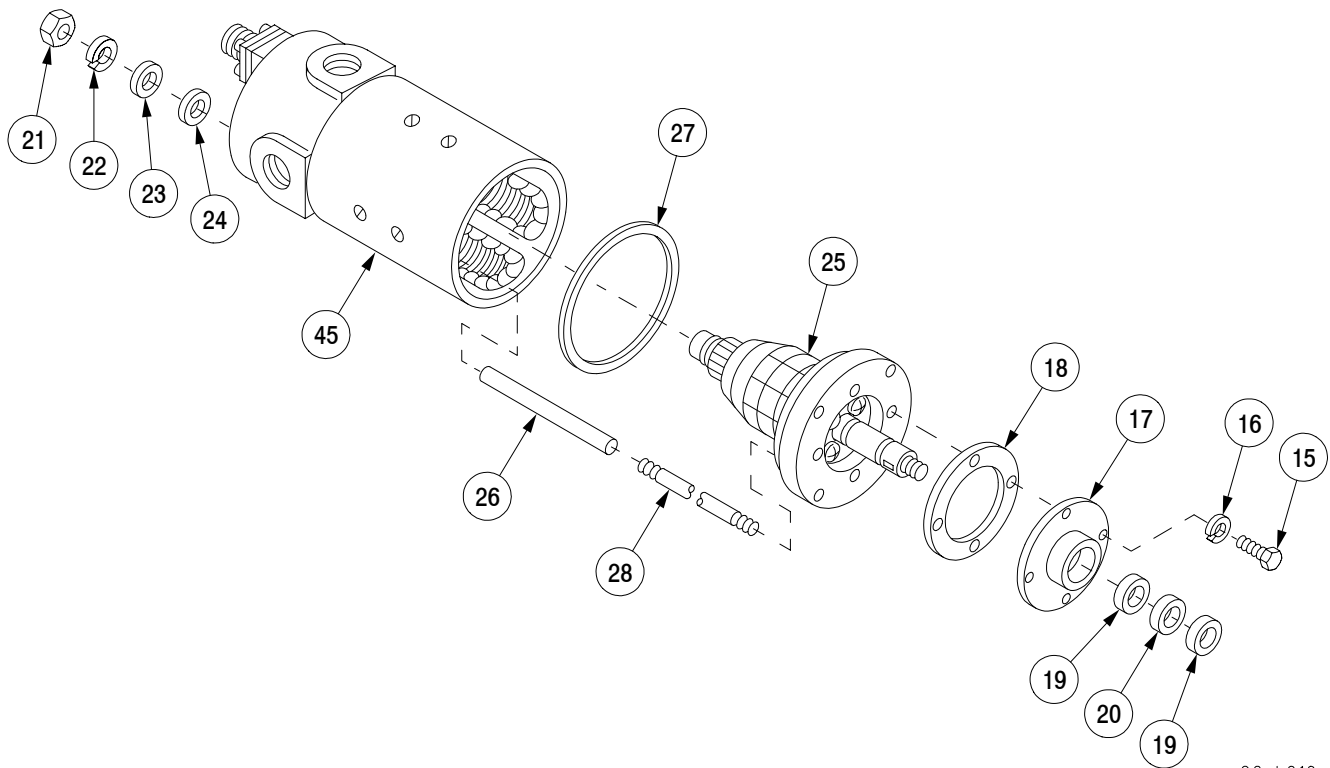

22ph010m

BILGE PUMP - CONTINUED

c. Assembly - Continued

- 14 Install key (14) and impeller housing (13).
- 15 Install impeller (12) in impeller housing (13) with new lockwasher (11) and round nut (10).
- 16 Install impeller cover (9) with four bolts (7) and four new lockwashers (8).
- 17 Install inlet screen (6) with four screws (4) and four new lockwashers (5).
- 18 Install four new brushes (3), four new preformed packings (2), and four brush caps (1).
- 19 Test operation of bilge pump using 24 volt power source.

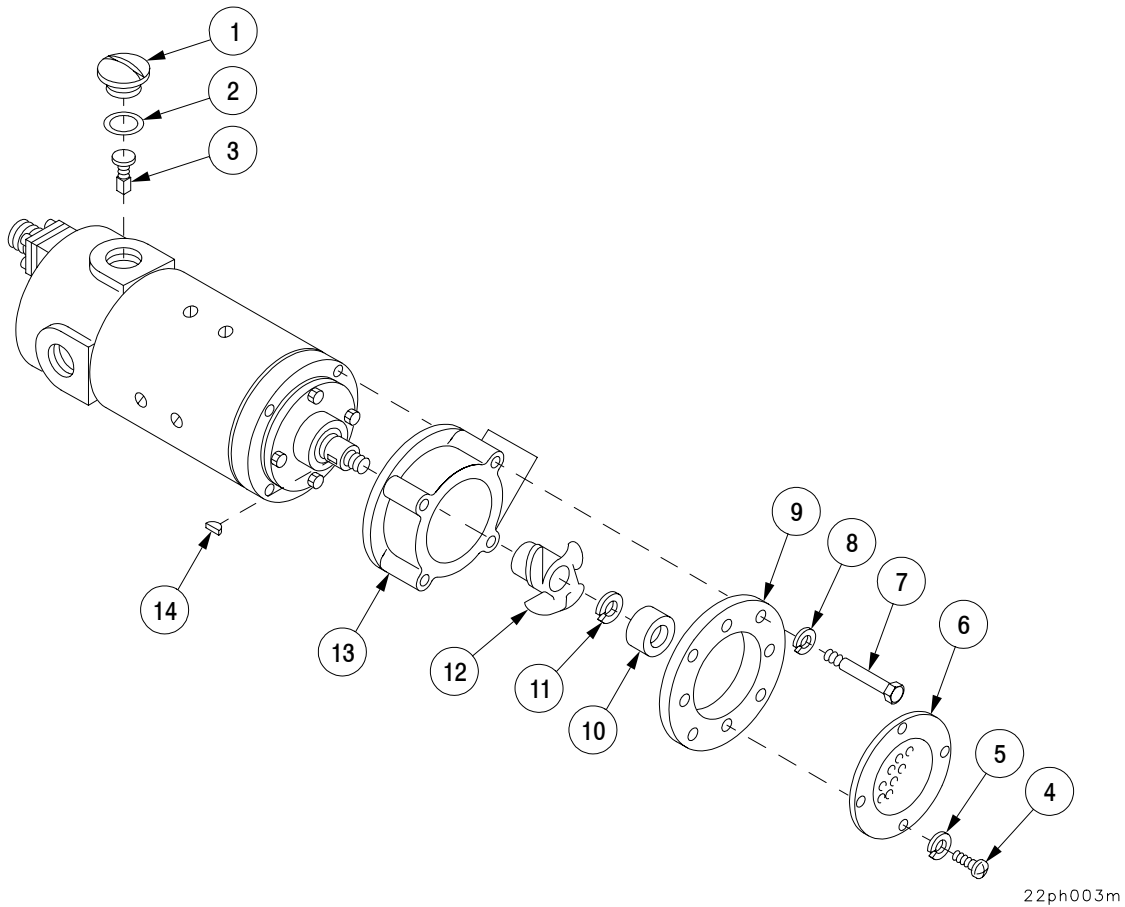
**NOTE**

FOLLOW-ON MAINTENANCE:
Install bilge pump (TM 9-2350-314-20-1-2)

CHAPTER 12 SPECIAL PURPOSE KITS

GENERAL

This chapter illustrates and defines procedures for removal, disassembly, testing, adjustment, assembly, and installation of special purpose kits and related components.

<u>CONTENTS</u>	<u>PAGE</u>
Section I. WINTERIZATION KIT INSTALLATION	
12-1 WINTERIZATION KIT INSTALLATION	12-2
Section II. WINTERIZATION KIT COMPONENTS	
12-2 BLOWER MOTOR ASSEMBLY	12-19
12-3 ENGINE COOLANT HEATER ASSEMBLY	12-22
12-4 ENGINE COOLANT HEATER ASSEMBLY TEST AND ADJUSTMENT	12-33
12-5 HEATER CONTROL BOX AND BRACKET	12-37
Section III. VENTILATION KIT INSTALLATION	
12-6 VENTILATION KIT	12-41



Section I. WINTERIZATION KIT INSTALLATION.

12-1 WINTERIZATION KIT INSTALLATION.

This task covers: Installation

INITIAL SETUP

Tools

General mechanic's tool kit
(SC 5180-90-N26)
Portable drill (item 16, Appx F)
Twist drill set (item 17, Appx F)
Screw threading set (item 50, Appx F)
Trailer-mounted welding shop
(item 54, Appx F)
Suitable container

Materials/Parts

Protective dust cap (item 41, Appx E)
Lockwashers (2) (item 62, Appx E)

Equipment Conditions

Vehicle MASTER switch OFF
(TM 9-2350-314-10)
Cooling system drained
(TM 9-2350-314-10)

Personnel Required

Three

References

TM 9-2350-314-10
TM 9-2350-314-20-1-2
TM 9-237

Installation.

- 1 Remove batteries and mounting components (TM 9-2350-314-20-1-2). Retain all parts for kit installation except battery support hold-down screws.
- 2 Place batteries' wiring leads (1) on hull front slope plate (2) to allow clearance for installation of winterization kit components.
- 3 Place battery side insulation (3) through rear access opening (4), placing bottom edges of battery side insulation (3) between battery support mounting blocks (5) and hull walls.

NOTE

Make certain bottom insulation cut-outs are aligned with battery support mounting blocks.

- 4 Insert bottom insulation (6) through front battery access opening (7) and locate bottom insulation (6) on battery support mounting blocks (5) front access opening (7).
- 5 Insert bottom insulation (8) through front battery access opening (7) and locate bottom insulation (8) on battery support mounting blocks (5) in rear access opening (4). Secure bottom insulation (6) and bottom insulation (8) together with lock wire (9).
- 6 Place two grommets (10) on battery heater (11) inlet and outlet tubes and install battery heater (11) through front battery access opening (7). Insert tube grommets (10) in battery side insulation (3) cut-outs.

Section I. WINTERIZATION KIT INSTALLATION - CONTINUED

12-1 WINTERIZATION KIT INSTALLATION - CONTINUED

Installation - Continued

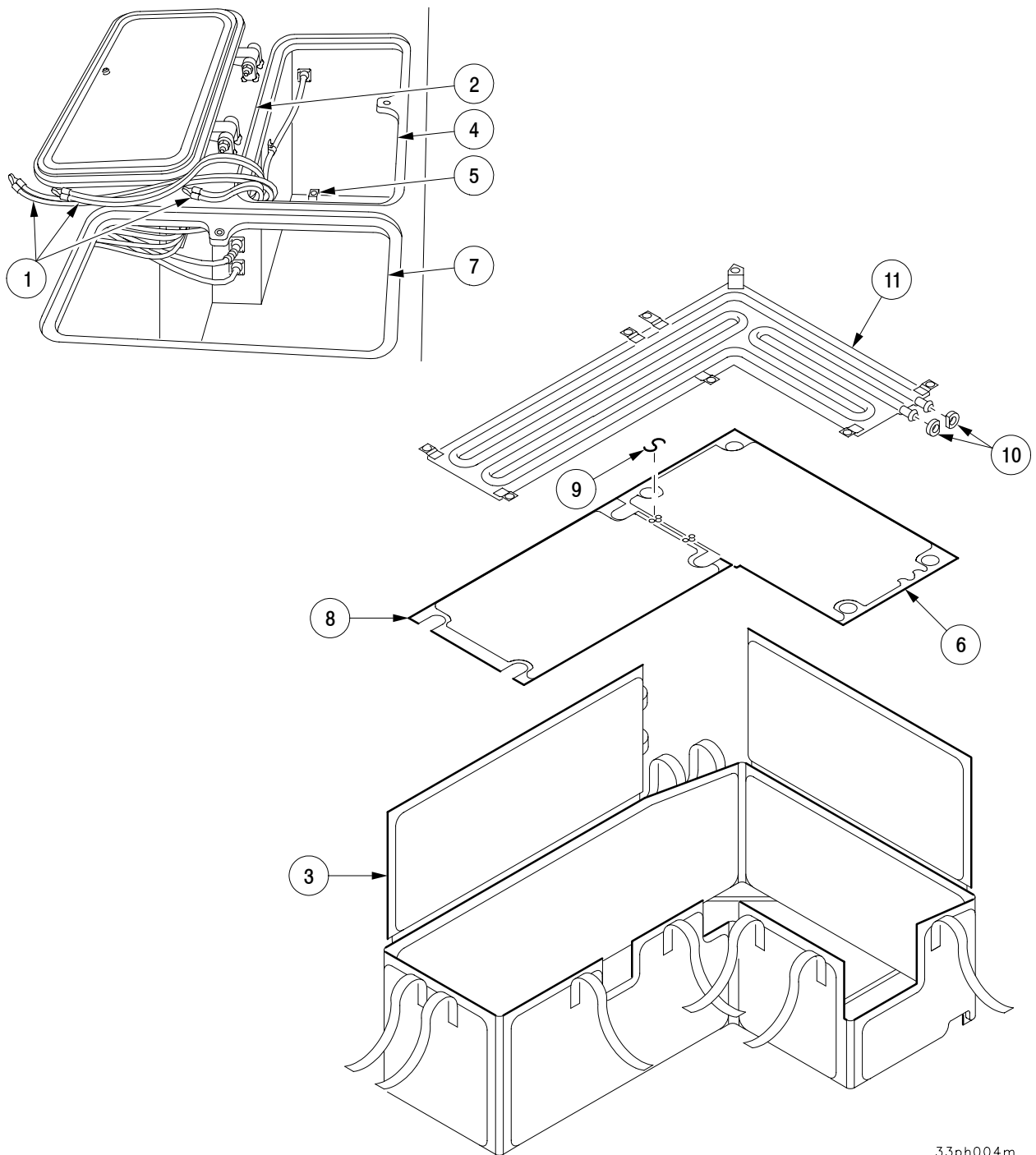

33ph004m

Section I. WINTERIZATION KIT INSTALLATION - CONTINUED

12-1 WINTERIZATION KIT INSTALLATION - CONTINUED

Installation - Continued

NOTE

Four screws and 24 flat washers are provided for shimming adjustment of support to make it level. Use of shims (washers) should be kept to a minimum.

- 7 Install battery supports (12) on sponson with eight screws (13), eight lockwashers (14), and shims (15) if necessary.
- 8 Place four batteries (16) on two battery supports (12) with battery terminals positioned as illustrated. Secure with hold-down bars (17), bolts (18), lockwashers (19), and nuts (20).

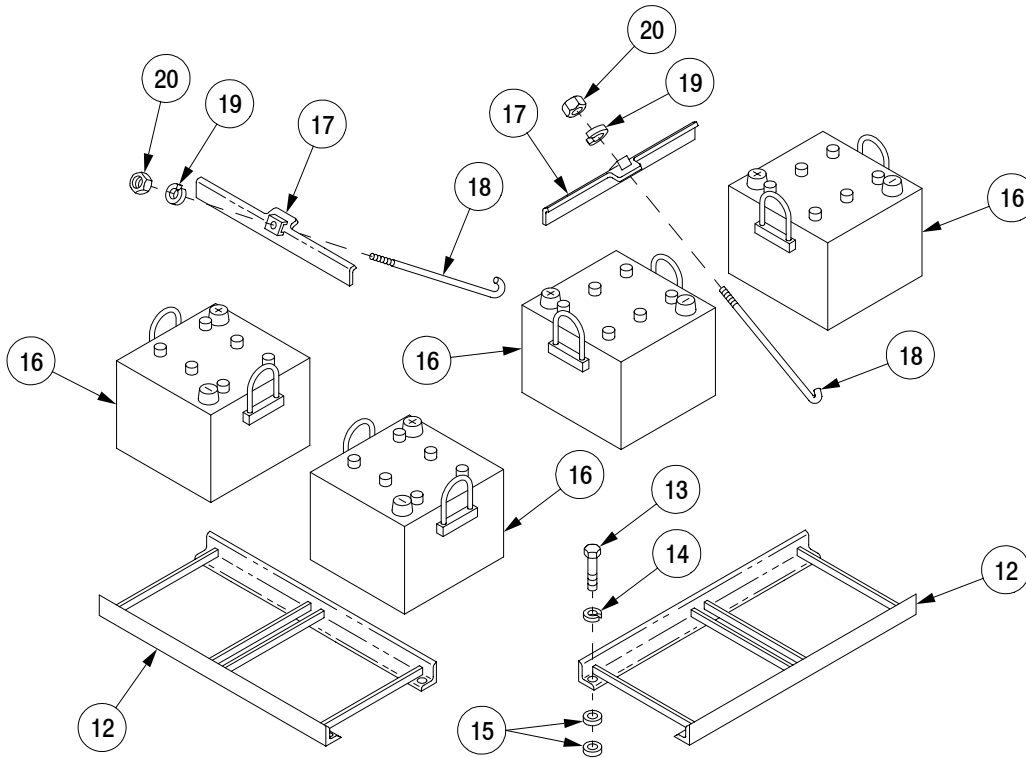

33ph005m

Section I. WINTERIZATION KIT INSTALLATION - CONTINUED

12-1 WINTERIZATION KIT INSTALLATION - CONTINUED

Installation - Continued

- 9 Open transmission left and right access doors and air-intake grille (TM 9-2350-314-10). Install four shock mounts (21) and coolant heater mounting brackets (22) on hull front plate (23) using four nuts (24), and four lockwashers (25).
- 10 Cut out three inches of existing engine inlet coolant hose (26) at a point midway between coolant heater mounting brackets (22). Discard hose section. Place hose clamp (27) over each hose end, insert "Y" tube (28), and tighten hose clamps (27).
- 11 Place hose clamp (29) over end of hose (30). Install hose (30) on "Y" tube (28) and tighten hose clamp (29).

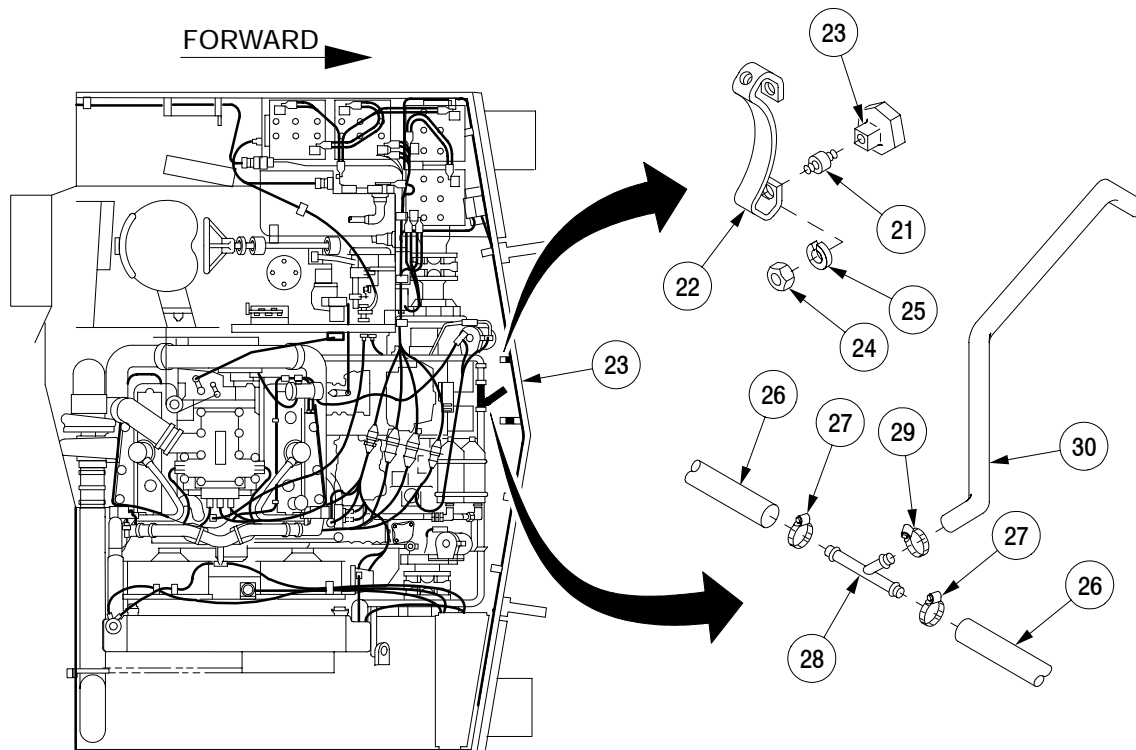

33ph006m

Section I. WINTERIZATION KIT INSTALLATION - CONTINUED

12-1 WINTERIZATION KIT INSTALLATION - CONTINUED

Installation - Continued

- 12 Place heater exhaust assembly (31) with hose clamp (32) in mounted position between coolant heater mounting brackets (22).
- 13 Install coolant heater outlet elbow (33) on coolant heater assembly (34).
- 14 Place hose clamp (35) over end of hose (36) and install on coolant heater assembly (34). Tighten hose clamp (35).
- 15 Place coolant heater assembly (34) on powerpack compartment. Attach heater exhaust assembly (31) and tighten hose clamp (32) with screw (37).
- 16 Place coolant heater assembly (34) on mounting brackets (22) and clamp securely with four brackets (38), four screws (39), two screws (40), two lockwashers (41), and four nuts (42).

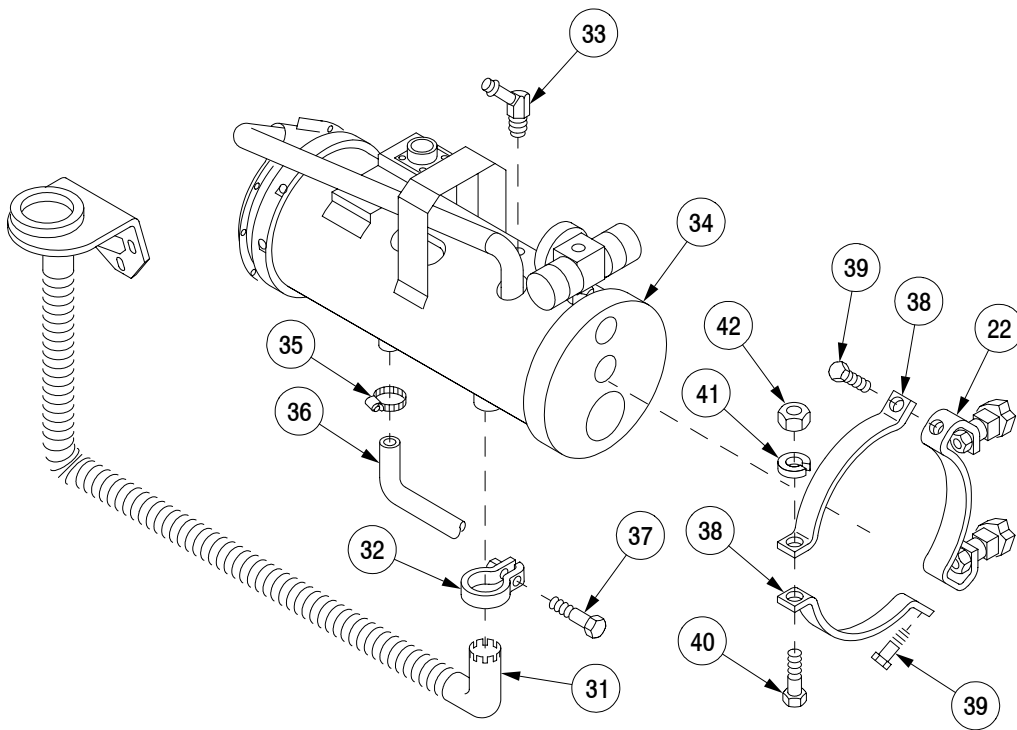

33ph007m

Section I. WINTERIZATION KIT INSTALLATION - CONTINUED

12-1 WINTERIZATION KIT INSTALLATION - CONTINUED

Installation - Continued

- 17 Install exhaust tube and support bracket (43) on three hull front plate tapping blocks (44) with three screws (45), three lockwashers (46), and three flat washers (47). Close transmission access door to position exhaust tube end gasket (48). Reopen door and tighten screws (45).
- 18 Place clamp (49) on free end of hose (30) and install hose coolant heater outlet elbow (33). Tighten clamp (49).

NOTE

Retain screws, flat washers, and gasket for use in installation of exhaust outlet.

- 19 Remove heater exhaust cover (50), three screws (51), and three flat washers (52) from inside of left transmission access door (53). Lift cover and gasket (54) from outside surface of door (53).
- 20 Install exhaust outlet (55) on left transmission access door (53) using three screws (51), three flat washers (52), and gasket (54) retained from heater exhaust cover (50) removal.
- 21 Install exhaust outlet plug (56) in exhaust outlet (55).

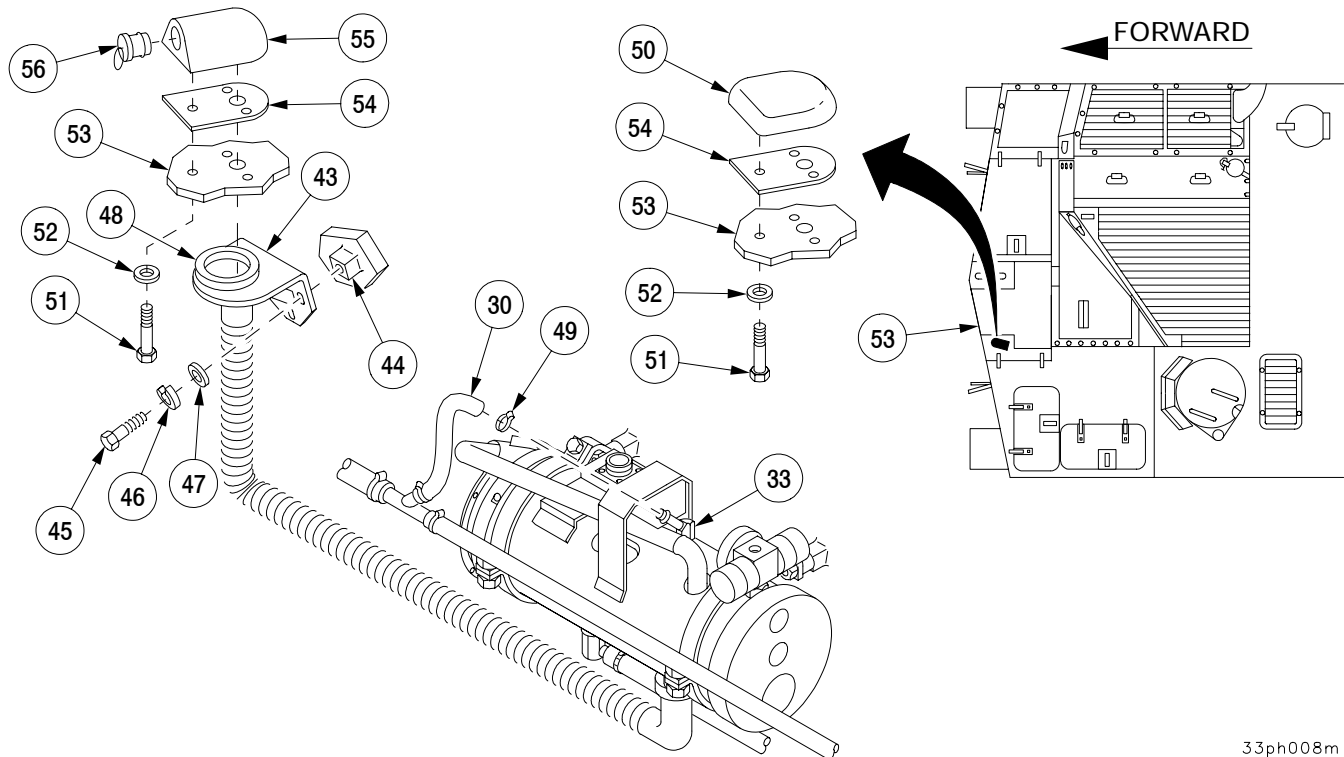

33ph008m

Section I. WINTERIZATION KIT INSTALLATION - CONTINUED

12-1 WINTERIZATION KIT INSTALLATION - CONTINUED

Installation - Continued

CAUTION

Remove plug from exhaust outlet before operating winterization kit. Failure to comply could damage vehicle.

- 22 Remove three screws (57) from engine coolant pump inlet adapter (58). Discard screws.
- 23 Position engine coolant pump (59) with adapter (58) against base bracket (60) so that pump suppressor (61) is 30 in. (762 mm) forward from a vertical position (to clear hull front plate) and install three screws (62) and three lockwashers (63).
- 24 Place curved bracket (64) over engine coolant pump (59) and secure to base bracket (6) with two screws (65), two flat washers (66), and two nuts (67).

NOTE

Lockwashers may be installed on any two screws for grounding pump to hull.

- 25 Install assembled engine coolant pump (59) and base bracket (60) on hull front plate (23) with four screws (68), two flat washers (69), and two lockwashers (70).
- 26 Place hose clamp (71) over free end of hose (36) and connect hose (36) to coolant pump outlet (72). Tighten hose clamp (71).
- 27 Install adapter (73) in fuel filter (74) inlet and elbow (75) in fuel filter (74) outlet.
- 28 Install fuel filter (74) with elbow (75) and adapter (73) on bracket (76) with two screws (77), two flat washers (78), and two nuts (79).
- 29 Install adapter (80) in electric fuel pump inlet (81) and adapter (82) in electric fuel pump outlet (83).
- 30 Install two shock mounts (84) with two nuts (85) and two flat washers (86) on bracket (76). Install electric fuel pump (87) on shock mounts (84) with two nuts (88), one lockwasher (89), and two flat washers (90) to secure fuel pump (87), ground strap (91), and pump suppressor (92). Install fuel tube (93) between filter elbow (75) and fuel pump body adapter (82).

NOTE

Lockwasher must be installed between ground strap and screw head.

Section I. WINTERIZATION KIT INSTALLATION - CONTINUED

12-1 WINTERIZATION KIT INSTALLATION - CONTINUED

Installation - Continued

- 31 Install bracket (76) with fuel filter (74), fuel pump (87), and ground strap (91) to hull front plate (23) with two screws (94), flat washer (95), and lockwasher (96).
- 32 Remove plug from engine coolant right manifold (97) and install elbow (98).
- 33 Place hose clamp (99) over end of hose (100) and install hose (100) on elbow (98). Tighten clamp (99).
- 34 Place hose clamp (101) over end of hose (102). Install hose (102) on engine coolant pump inlet adapter (103). Tighten clamp (101).
- 35 Install engine primary fuel filter-to-coolant heater fuel filter hose (104) on filter adapter (73).
- 36 Place coolant manifold hose (100) along the side and front of transmission and connect to the battery heater inlet tube (105). Trim hose (100) to fit and install on heater inlet tube (105) with hose clamp (106).
- 37 Place coolant pump inlet hose (102) along front of transmission and connect to battery heater outlet tube (107). Trim hose (102) to fit and install on heater outlet tube (107) with hose clamp (108).
- 38 Secure hoses (100 and 102) to transmission with strap material using transmission screws and washers.

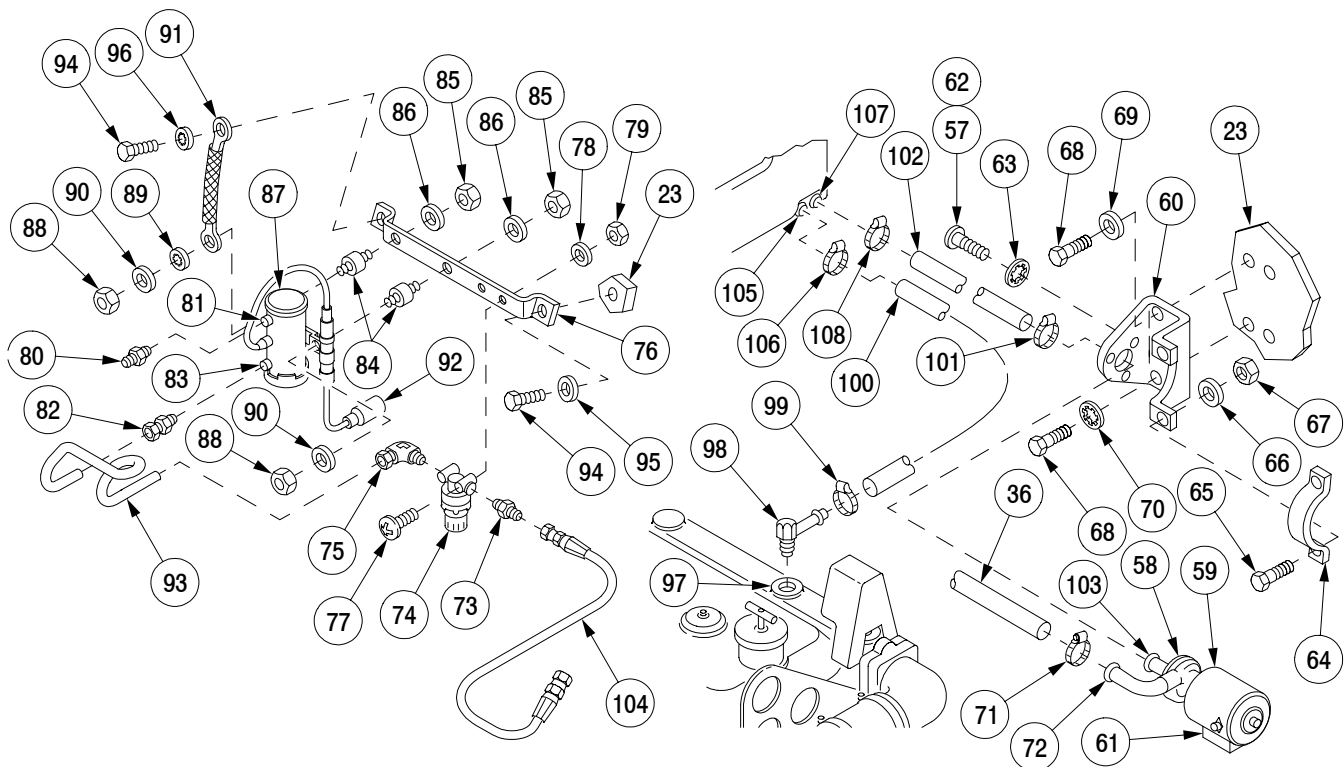

33ph009m

Section I. WINTERIZATION KIT INSTALLATION - CONTINUED

12-1 WINTERIZATION KIT INSTALLATION - CONTINUED

Installation - Continued

- 39 Disconnect fuel main supply hose (109) at primary filter quick-disconnect coupling (110) on primary fuel filter (111).
- 40 Remove plug on primary fuel filter (111) top inlet opening and install elbow (112). Discard plug.
- 41 Place coolant heater fuel filter-to-primary fuel hose (104) along left side of powerpack compartment and install on primary fuel filter elbow (112).
- 42 Use strap material to secure fuel hose (104) at three places on powerpack using powerpack screws and washers.
- 43 Install elbow (113) at heater fuel control valve (114) inlet opening. Install fuel pump-to-fuel control valve tube (115) between valve elbow (113) and heater fuel pump adapter (80).
- 44 Connect fuel main supply hose (109) to primary filter quick-disconnect coupling (110).

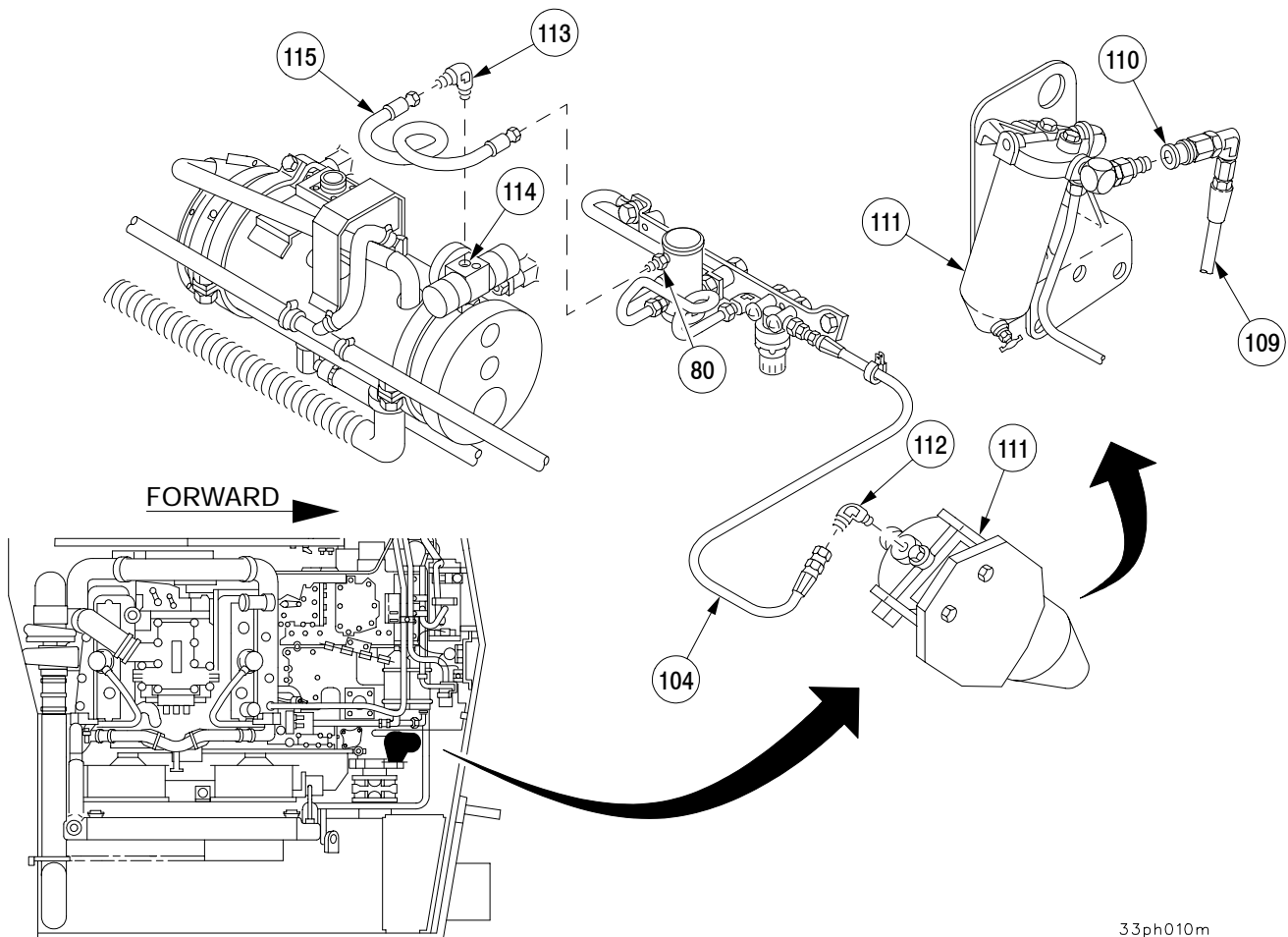

33ph010m

Section I. WINTERIZATION KIT INSTALLATION - CONTINUED

12-1 WINTERIZATION KIT INSTALLATION - CONTINUED

Installation - Continued

- 45 Remove battery compartment access port cover and gasket (TM 9-2350-314-20-1-2). Discard cover, gasket, and attaching hardware.
- 46 Install coolant heater harness receptacle (116) with new gasket (117), four screws (118), four lockwashers (119), and four nuts (120).
- 47 Connect coolant heater harness plug (121) to heater receptacle (122).

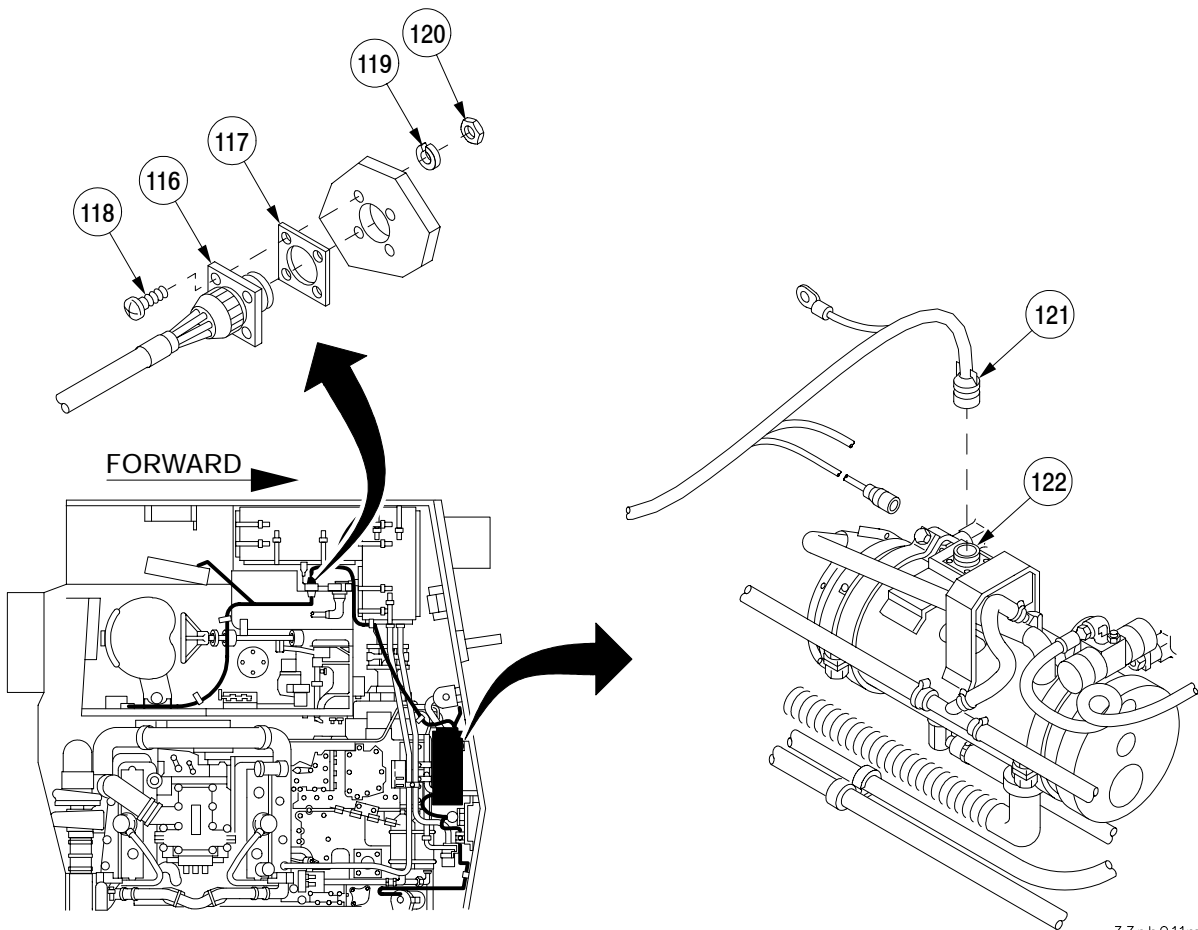

33ph011m

Section I. WINTERIZATION KIT INSTALLATION - CONTINUED

12-1 WINTERIZATION KIT INSTALLATION - CONTINUED

Installation - Continued

NOTE

Coolant heater harness lead 403B is supported with right headlight group harness strap.

- 48 Connect coolant heater harness lead 403B (123) to heater coolant pump (59).
- 49 Connect coolant heater harness lead 402C (124) to electric fuel pump (87).
- 50 Remove mounting screw (39) from coolant heater mounting bracket (38) and install coolant heater harness GND lead (125).

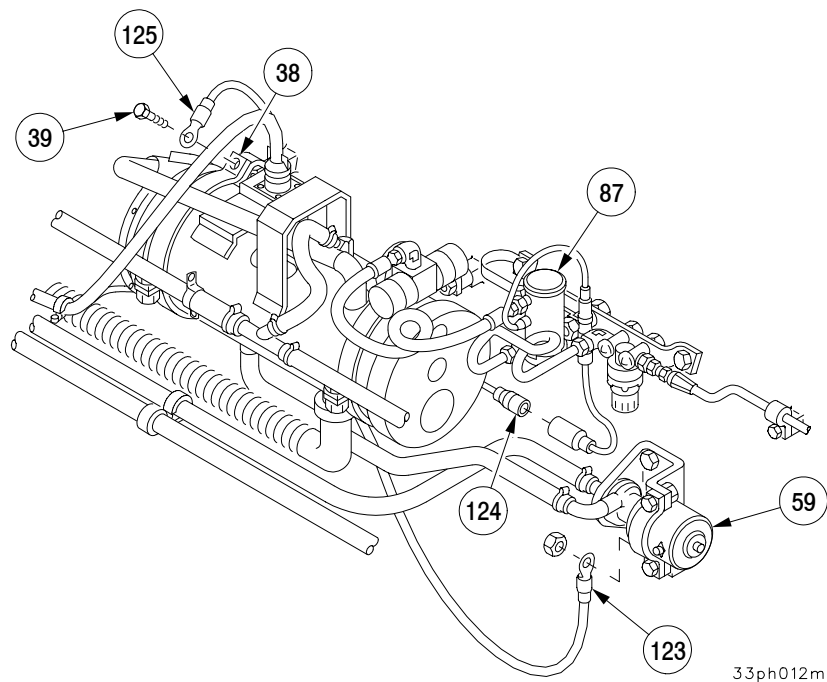

Section I. WINTERIZATION KIT INSTALLATION - CONTINUED

12-1 WINTERIZATION KIT INSTALLATION - CONTINUED

Installation - Continued

- 51 Remove two screws (126) and cover (127) from winterization kit heater control box (128).

NOTE

Harness receptacle must face downward. Reposition if necessary.

- 52 Remove two nuts (129) and two lockwashers (130) from screws (131) on top of winterization heater control box (128), discard lockwashers, place mounting bracket (132) on screws (131), and re-install two nuts (129) and two new lockwashers (130).
- 53 Install cover (127) on winterization heater control box (128) with two screws (126).
- 54 Install winterization heater control box (128) and mounting bracket (132) on driver's compartment bulkhead tapping blocks (133) above engine compartment access door with two screws (134) and two flat washers (135).
- 55 Connect winterization heater control box-to-driver's compartment harness plug (136) to winterization heater control box (128). Connect winterization heater control box driver's compartment harness lead 400 (137) to winterization heater control box lead (138). Remove one screw (134) and one flat washer (135) from forward end of winterization heater control box bracket (132) and secure harness to winterization heater control box bracket (132) with strap (139), one flat washer (135), and one screw (134).

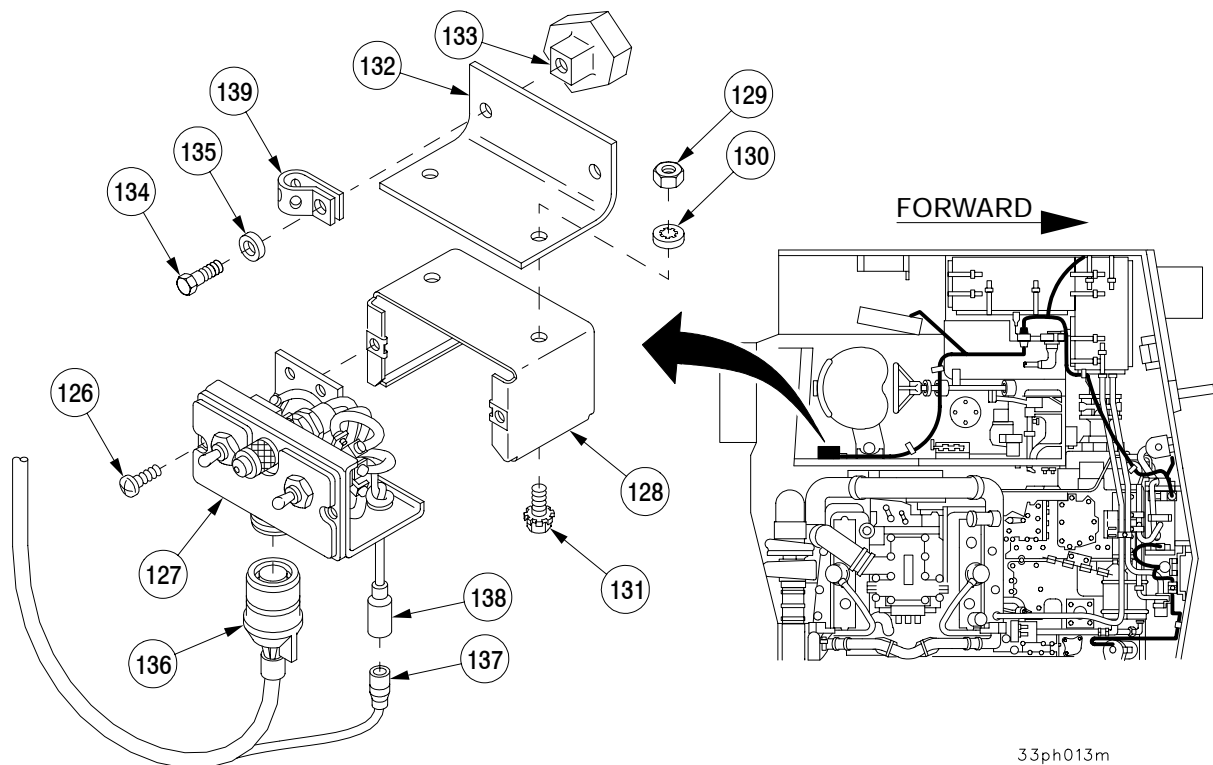

33ph013m

Section I. WINTERIZATION KIT INSTALLATION - CONTINUED

12-1 WINTERIZATION KIT INSTALLATION - CONTINUED

Installation - Continued

- 56 Connect winterization heater control box-to-driver's compartment harness plug (140) to coolant heater harness receptacle (116) at driver's compartment bulkhead.
- 57 Disconnect wiring harness W114 lead 486A (141) from GLOW PLUG ENABLE switch (142) behind driver's instrument panel.
- 58 Connect winterization heater control box-to-driver's compartment harness lead 400 (143) to wiring harness W114 lead 486A (141).
- 59 Connect winterization heater control box-to-driver's compartment harness lead 400 (144) to GLOW PLUG ENABLE switch (142).
- 60 Install battery leads (TM 9-2350-314-20-1-2).

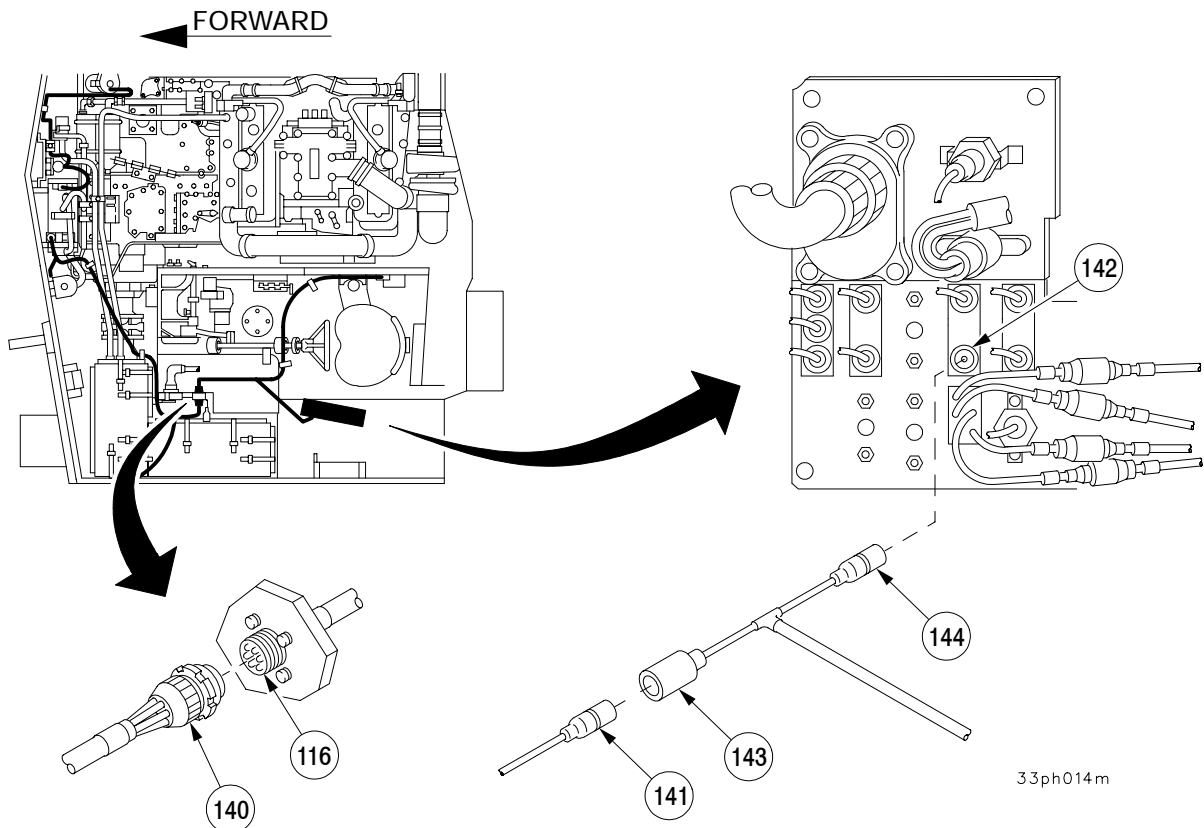

33ph014m

Section I. WINTERIZATION KIT INSTALLATION - CONTINUED

12-1 WINTERIZATION KIT INSTALLATION - CONTINUED

Installation - Continued

- 61 Close and secure upper insulation blanket (145) in rear battery compartment (146).
- 62 Close and secure upper insulation blanket (147) in forward battery compartment (148).

NOTE

Make certain plug is installed in petcock valve of lower main coolant tube prior to filling radiator.

- 63 Close drain valve (149) in lower main coolant tube (150).

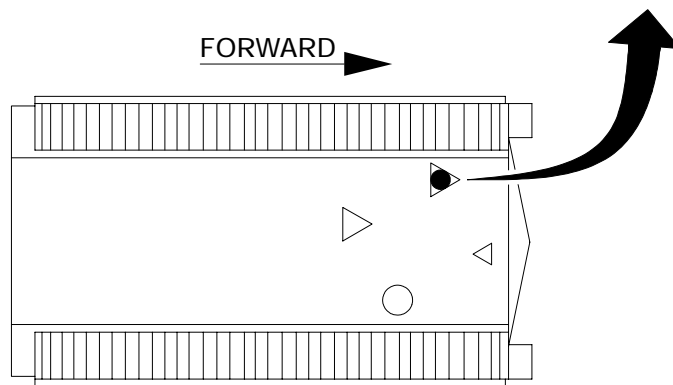
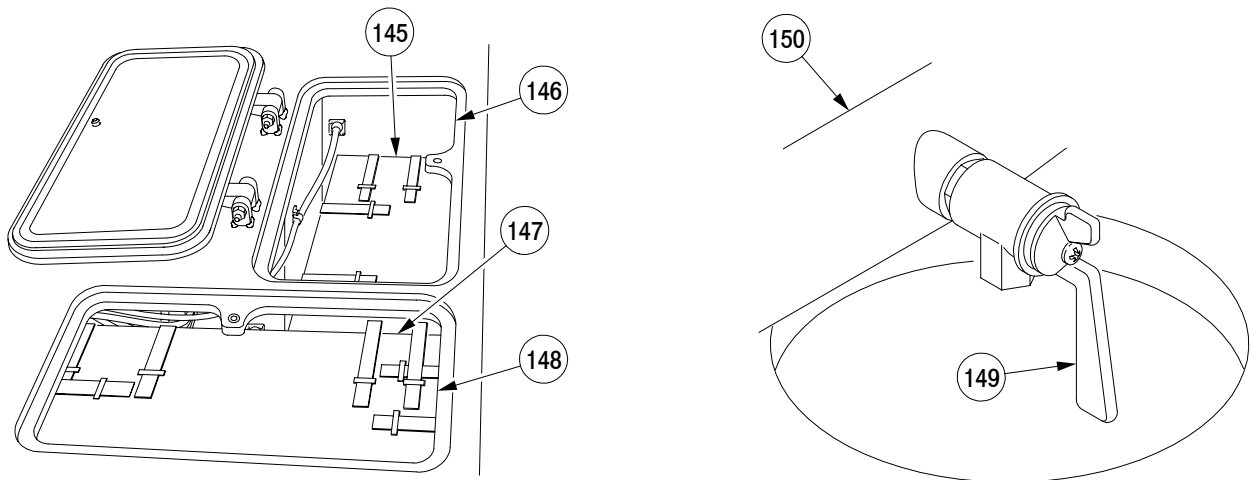

BOTTOM VIEW
OF VEHICLE

33ph016m

Section I. WINTERIZATION KIT INSTALLATION - CONTINUED

12-1 WINTERIZATION KIT INSTALLATION - CONTINUED

Installation - Continued

- 64 Loosen hose clamp (99) and disconnect coolant hose (100) at elbow (98) on engine right bank coolant manifold (97).
- 65 Place protective cap over elbow (98) and hold disconnected coolant hose (100) end in suitable container.
- 66 Fill cooling system (TM 9-2350-314-10).

NOTE

- Do not overdrain coolant system. Return drained coolant to radiator, and then continue air bleed procedure.
 - Air bleed should always be performed after removal or replacement of coolant heater or any coolant line.
- 67 Start engine (TM 9-2350-314-10) and run for short period. Observe flow of air and coolant out of disconnected hose (100). Continue until flow of coolant is without air bubbles.
 - 68 Shut down engine (TM 9-2350-314-10) and remove protective cap from elbow (98) and connect coolant hose (100) at elbow (98) on engine right bank coolant manifold (97). Tighten hose clamp (99). Discard protective cap.

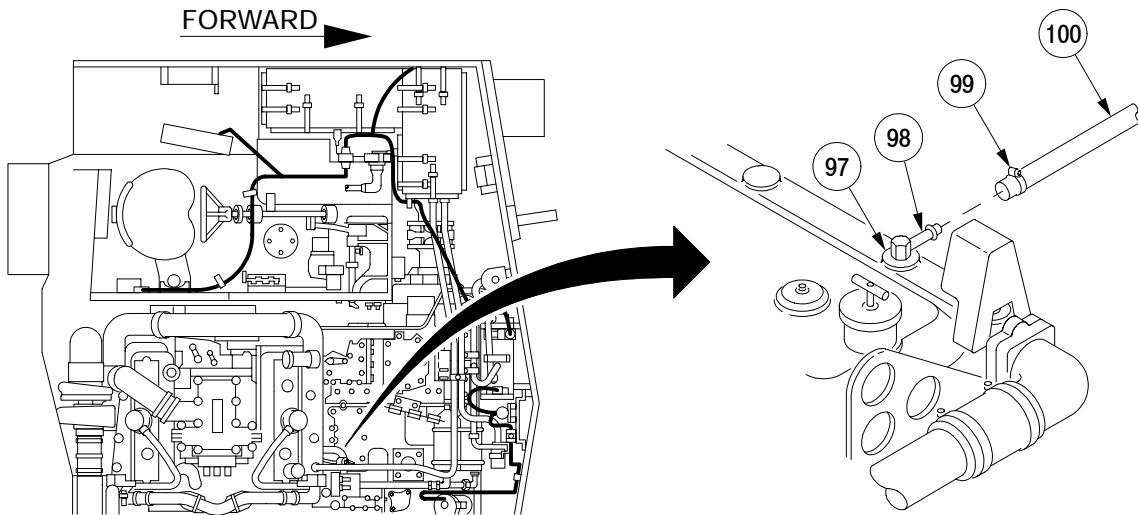

33ph017m

Section I. WINTERIZATION KIT INSTALLATION - CONTINUED

12-1 WINTERIZATION KIT INSTALLATION - CONTINUED

Installation - Continued

- 69 Place hold-down strip (151) for intake grille cover tarpaulin (152) on intake grille (153) to serve as template for screw holes. Mark holes and remove hold-down strip (151). Drill and tap six 5/16-24 UNF-28 holes.

NOTE

Before proceeding, see detailed instructions on welding and welding materials (TM 9-237).

- 70 Weld ten footman's loop fasteners (154) into place using intake grille cover tarpaulin (152) and straps (155) as a template.
- 71 Place intake grille winterization tarpaulin (152) in position with straps (155) and webbing down. Install six screws (156) and six flat washers (157) in hold-down strip (151).
- 72 Secure tarpaulin (152) by installing ten straps (155) into ten footman's loop fasteners (154).

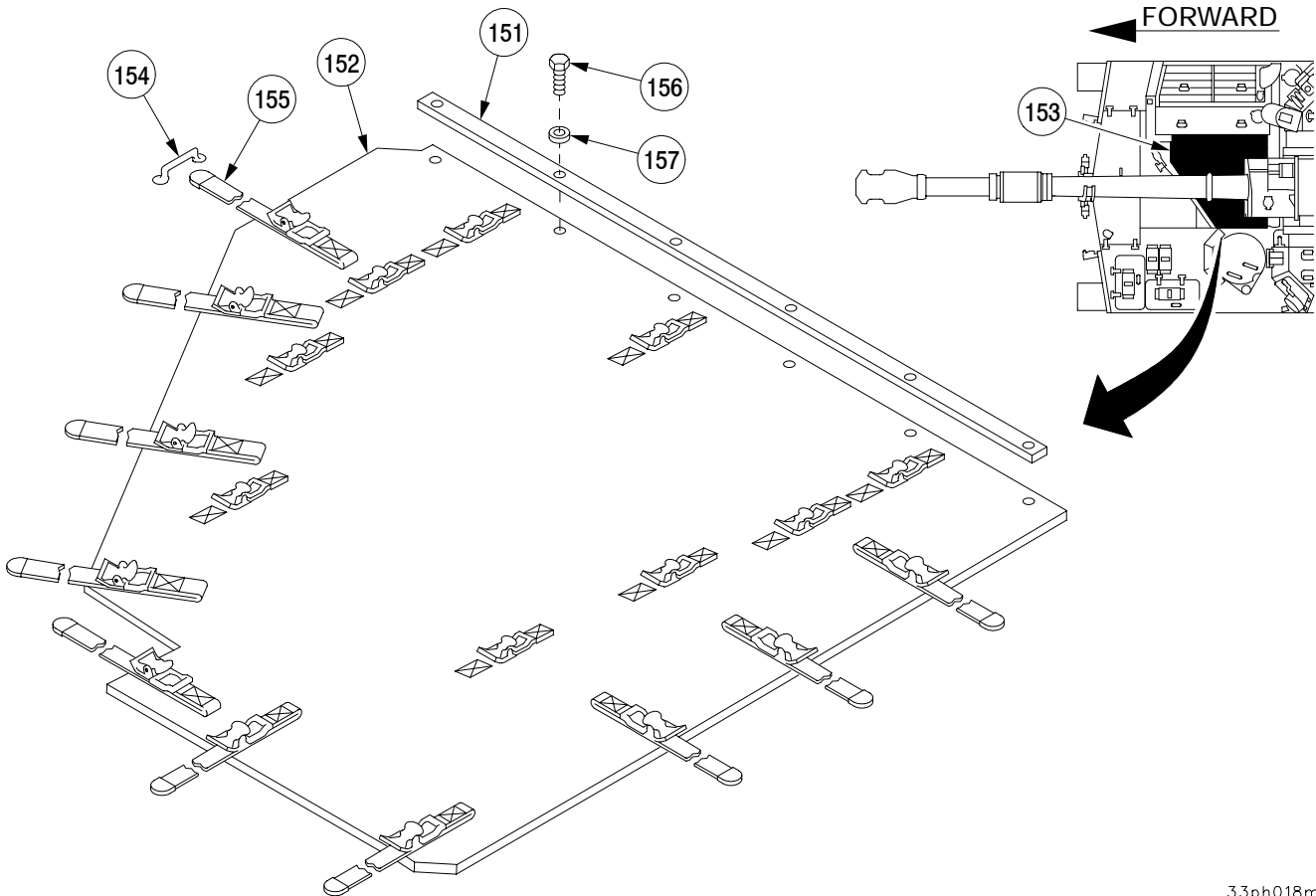

33ph018m

Section I. WINTERIZATION KIT INSTALLATION - CONTINUED

12-1 WINTERIZATION KIT INSTALLATION - CONTINUED

Installation - Continued

- 73 Remove four screws (158) from exhaust grille (159). Discard screws.
- 74 Place exhaust grille tarpaulin hold-down strip (160) on exhaust grille (159), align holes in exhaust grille tarpaulin hold-down strip (160) with four holes in exhaust grille (159). Mark hole and remove hold-down strip (160), drill and tap one 5/16-24 UNF-2B hole at forward end of exhaust grille (159).

NOTE

Before proceeding, see detailed instructions on welding and welding materials (TM 9-237).

- 75 Weld five footman's loop fasteners (161) on exhaust grille (159) using exhaust grill tarpaulin (162) and straps (163) as a template.
- 76 Secure exhaust grille tarpaulin hold-down strip (160) to exhaust grille (159) with screw (164), four screws (165), and five flat washers (166).
- 77 Secure exhaust grille tarpaulin (162) to exhaust grille (159) with five straps (163).

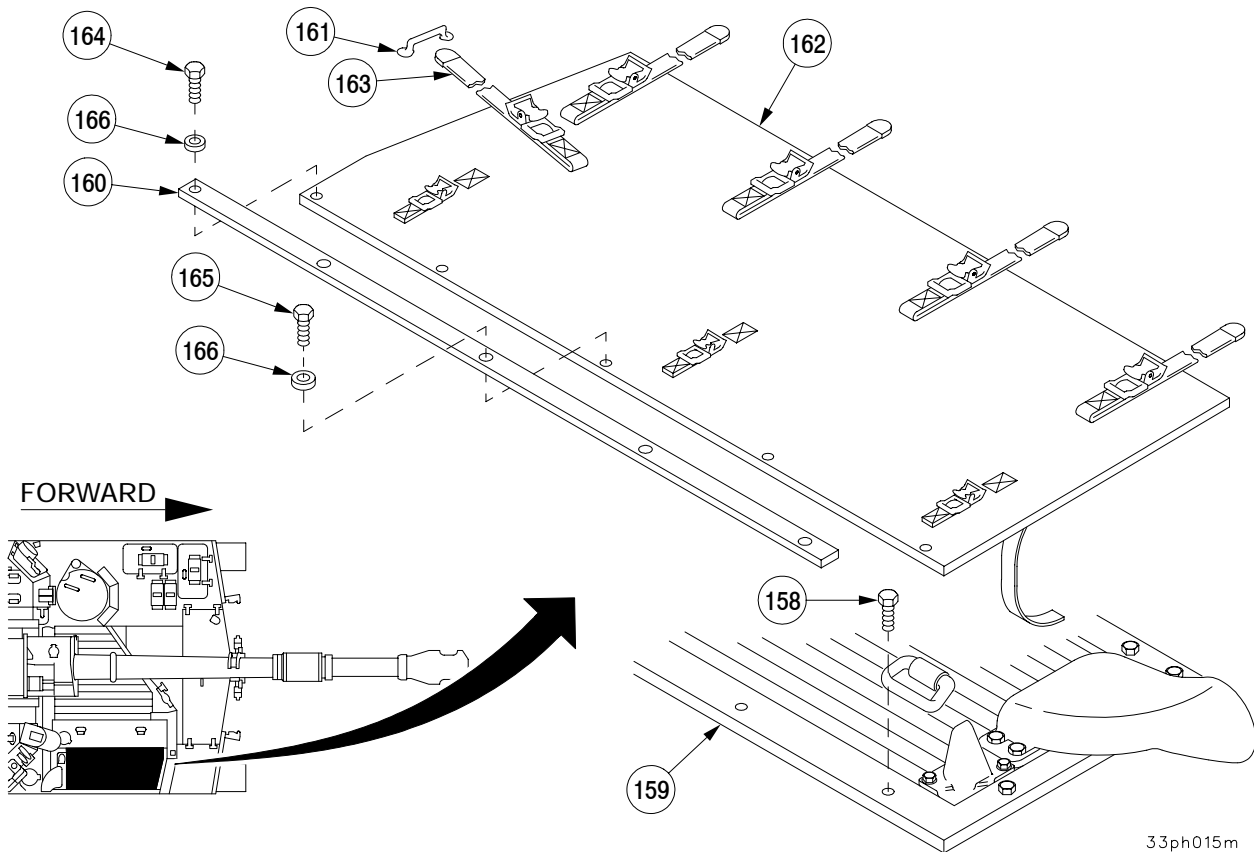

33ph015m

Section II. WINTERIZATION KIT COMPONENTS.

12-2 BLOWER MOTOR ASSEMBLY.

This task covers: a. Removal b. Disassembly c. Assembly d. Installation

INITIAL SETUP

Tools

Fuel and electrical tool kit (SC 5180-95-B08)

Equipment Conditions

Engine coolant heater assembly removed (TM 9-2350-314-20-1-2)

References

TM 9-2350-314-20-1-2

a. Removal.

- 1 Remove four screws (1) and guard assembly (2) from engine coolant heater assembly (3).
- 2 Remove nut (4), tube (5), elbow (6), and elbow (7) from engine coolant heater assembly (3).
- 3 Disconnect lead (8) from terminal strip (9) on engine coolant heater assembly (3).
- 4 Loosen four nuts (10).
- 5 Turn blower motor assembly (11) counterclockwise to clear slots and pull off end of engine coolant heater assembly (3).

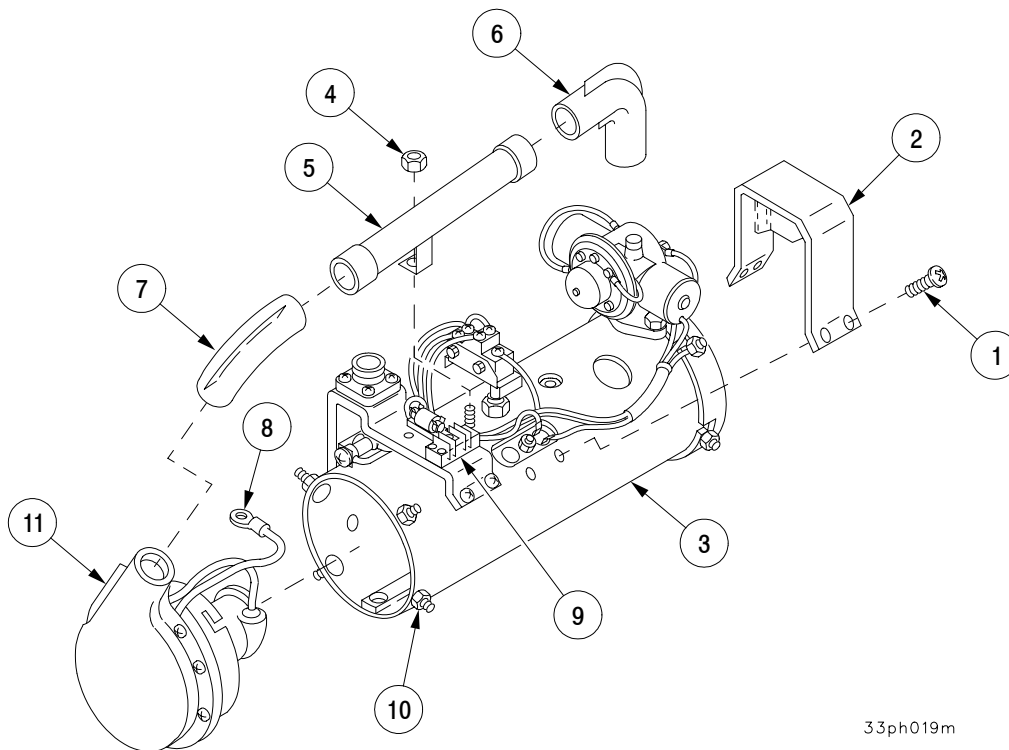

33ph019m

Section II. WINTERIZATION KIT COMPONENTS - CONTINUED

12-2 BLOWER MOTOR ASSEMBLY - CONTINUED

b. Disassembly.

- 1 Remove seven screws (12) and seven sheet nuts (13) from flange of blower motor cover (14).
- 2 Remove blower motor cover (14) and loosen setscrew (15) in hub of blower motor wheel (16). Remove blower motor wheel (16).
- 3 Remove three screws (17) securing blower motor plate (18) to blower motor (19).
- 4 Separate blower motor plate (18) from blower motor (19) and remove three grommets (20) and three spacers (21).

c. Assembly.

- 1 Install blower motor (19) to blower motor plate (18) with three grommets (20), three spacers (21), and three screws (17).
- 2 Install blower motor wheel (16) hub flush with motor shaft. Tighten setscrew (15) in hub.
- 3 Temporarily place blower motor cover (14) in position. Spin blower motor wheel (16) to make sure blower motor wheel (16) does not contact blower motor cover (14). If blower motor wheel (16) contacts blower motor cover (14), loosen setscrew (15), adjust blower motor wheel (16) on motor shaft until blower motor wheel (16) does not contact blower motor cover (14). Tighten setscrew (15).
- 4 Install blower motor cover (14) with seven screws (12) and seven sheet nuts (13).

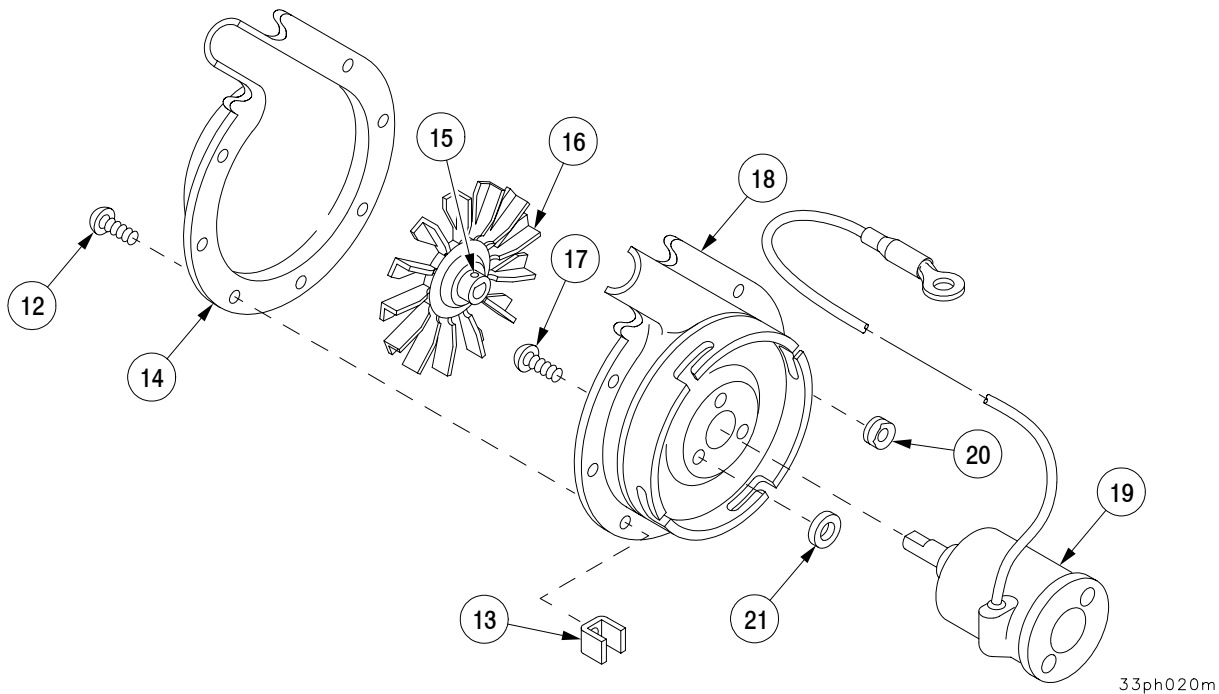

Section II. WINTERIZATION KIT COMPONENTS - CONTINUED

12-2 BLOWER MOTOR ASSEMBLY - CONTINUED

d. Installation.

- 1 Position blower motor assembly (11) on engine coolant heater assembly (3). Turn blower motor assembly (11) clockwise until secured in slots of engine coolant heater assembly (3).
- 2 Tighten four nuts (10).
- 3 Connect lead (8) to terminal strip (9) on engine coolant heater assembly (3).
- 4 Install tube (5), elbow (6), elbow (7), and nut (4) on engine coolant heater assembly (3).
- 5 Install guard assembly (2) and four screws (1) onto engine coolant heater assembly (3).

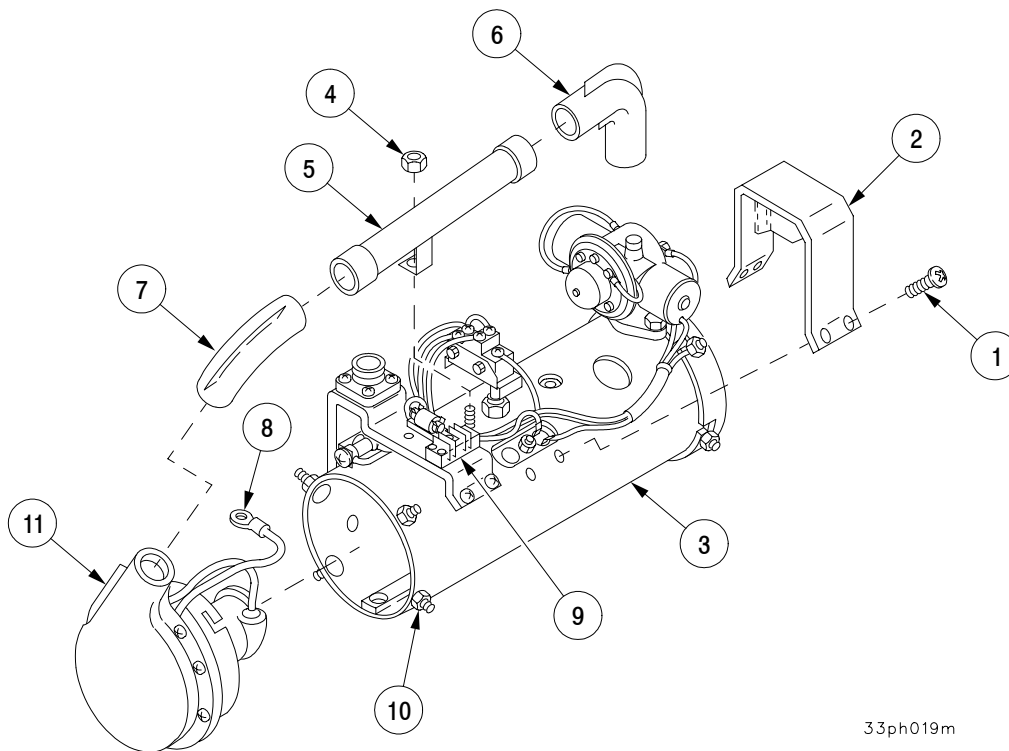

33ph019m

NOTE

FOLLOW-ON MAINTENANCE:
Install engine coolant heater assembly
(TM 9-2350-314-20-1-2)

Section II. WINTERIZATION KIT COMPONENTS - CONTINUED

12-3 ENGINE COOLANT HEATER ASSEMBLY.

This task covers: a. Disassembly b. Assembly

INITIAL SETUP

Tools

General mechanic's tool kit
(SC 5180-90-N26)
Hand riveter (item 37, Appx F)

Materials/Parts

Assembled screws (2) (item 17, Appx E)
Gasket (item 16, Appx E)
Assembled screw (item 37, Appx E)
Lockwasher (item 66, Appx E)
Preformed packing (item 29, Appx E)
Lockwasher (item 72, Appx E)
Assembled screws (4) (item 18, Appx E)

Materials/Parts - Continued

Tiedown straps (3) (item 57, Appx E)
Blind rivets (4) (item 19, Appx E)
Assembled nuts (2) (item 20, Appx E)
Gasket (item 27, Appx E)
Preformed packing (item 28, Appx E)
Compression sleeve (item 21, Appx E)

Equipment Condition

Blower motor assembly removed
(para 12-2)

a. Disassembly.

- 1 Remove four assembled screws (1) and receptacle (2) from bracket (3). Discard assembled screws.
- 2 Disconnect ground lead (4) from housing (5).
- 3 Disconnect lead (6) from restriction thermostat (7).
- 4 Disconnect lead (8) from overheat thermostat (9).
- 5 Disconnect two leads (10 and 11) from flame detector switch (12).
- 6 Remove three tiedown straps (13) from five receptacle leads (4, 6, 8, 10, and 11). Discard tiedown straps.
- 7 Remove sleeve (14) from five receptacle leads (4, 6, 8, 10, and 11).
- 8 Remove receptacle (2) from heater assembly.
- 9 Remove five screws (15) and three leads (16, 17, and 18) from flame detector switch (12).

Section II. WINTERIZATION KIT COMPONENTS - CONTINUED

12-3 ENGINE COOLANT HEATER ASSEMBLY - CONTINUED

a. Disassembly - Continued

CAUTION

Caution must be taken when removing compression sleeve from steel tube of flame detector switch. Compression sleeve will normally be seated against the probe. Failure to comply will result in equipment damage.

- 10 Loosen nut (19) and remove flame detector switch (12).
- 11 Remove compression sleeve (20) and nut (19) from flame detector switch (12). Discard compression sleeve.
- 12 Disconnect two leads (21 and 22) from connector (23) on overheat thermostat (9).
- 13 Disconnect lead (24) from terminal strip (25).
- 14 Loosen nut (26) from union (27) under fuel control valve (28).
- 15 Remove two screws (29) and control valve (28) from bracket (30) and tube (31).
- 16 Remove two screws (32) and bracket (30) from housing (5).
- 17 Disconnect lead (33) from overheat thermostat (9).

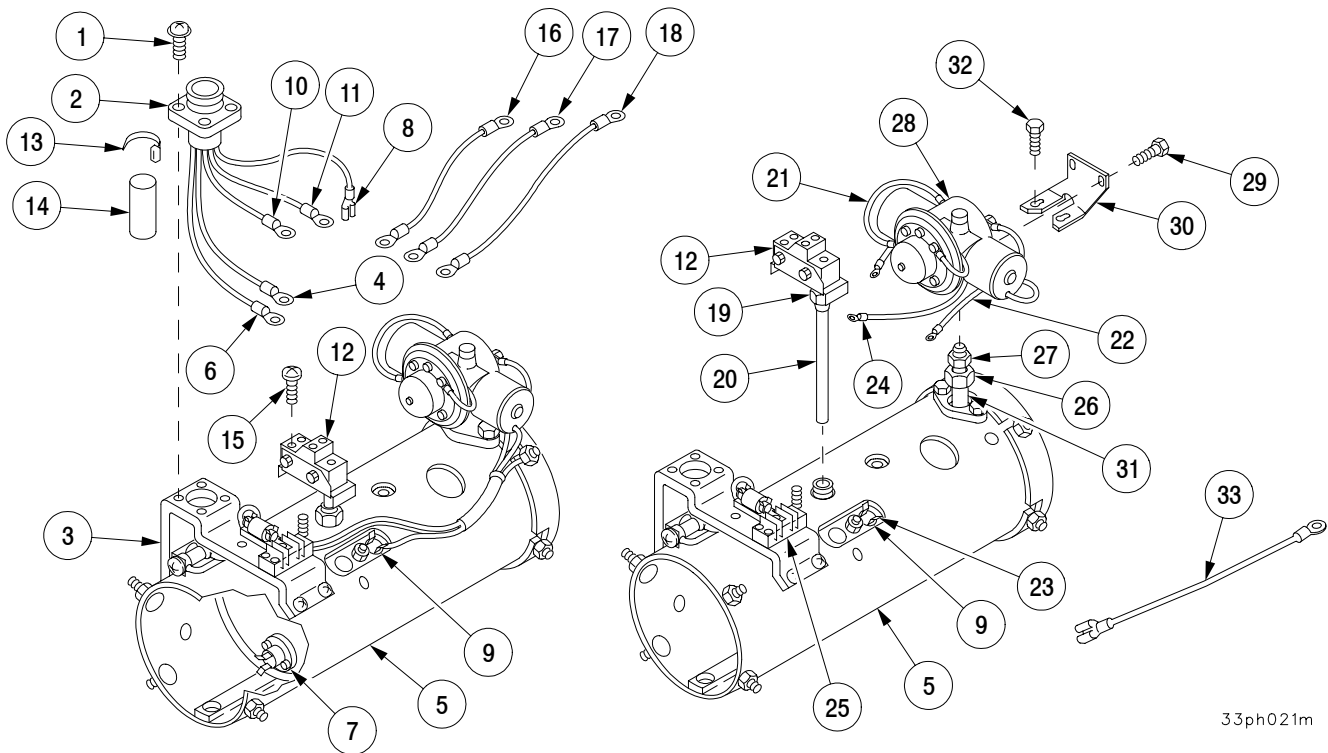

33ph021m

Section II. WINTERIZATION KIT COMPONENTS - CONTINUED

12-3 ENGINE COOLANT HEATER ASSEMBLY - CONTINUED

a. Disassembly - Continued

- 18 Remove nut (34), lockwasher (35), and retainer (36) from heat exchanger (37). Discard lockwasher.
- 19 Remove overheat thermostat (9), connector (23), flat washer (38), and preformed packing (39) from heat exchanger (37). Discard preformed packing.
- 20 Loosen four nuts (40) and remove end plate (41) from housing (5).
- 21 Remove assembled screw (42), lead (43), and lockwasher (44) from igniter (45). Discard assembled screw and lockwasher.
- 22 Remove two nuts (46) and preheat resistor (47) from igniter (45).
- 23 Remove igniter (45) and gasket (48) from burner assembly (49). Discard gasket.
- 24 Remove two screws (50) from tapping plate (51).
- 25 Leave flange (52) loose on fuel tube (31) and remove tapping plate (51).
- 26 Remove two assembled screws (53), two nuts (54), and cable (18) from resistor (47). Discard assembled screws.
- 27 Remove fuel tube (31) and resistor (47) as an assembly from burner assembly (49).

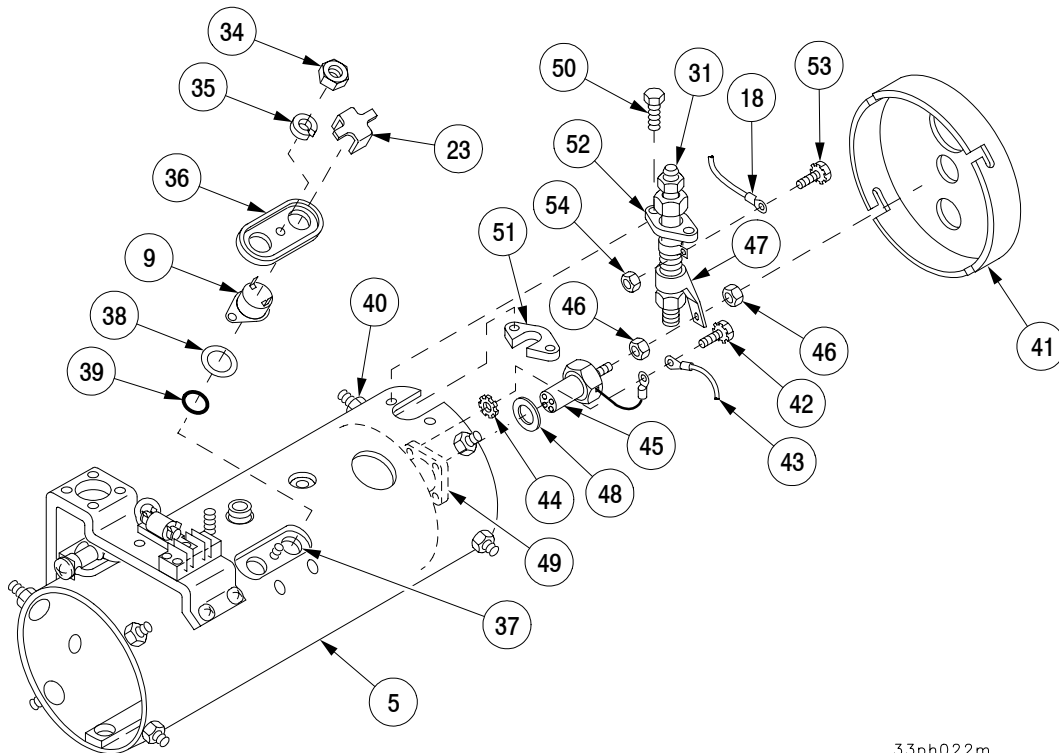

33ph022m

Section II. WINTERIZATION KIT COMPONENTS - CONTINUED

12-3 ENGINE COOLANT HEATER ASSEMBLY - CONTINUED

a. Disassembly - Continued

CAUTION

Compression sleeve is to be removed only if resistor requires replacement. Compression fitting is pressed securely to the fuel tube and will have to be cut or ground off.

NOTE

Compression sleeve must be removed before removing resistor from fuel tube.

- 28 Remove union (27), compression sleeve (55), nut (26), resistor (47), and flange (52) from fuel tube (31). Discard compression sleeve.
- 29 Remove two nuts (56), two clamps (57), and two hook bolts (58) securing burner assembly (49) to heat exchanger (37).
- 30 Remove burner assembly (49), preformed packing (59), and gasket (60) from heat exchanger (37). Discard preformed packing and gasket.

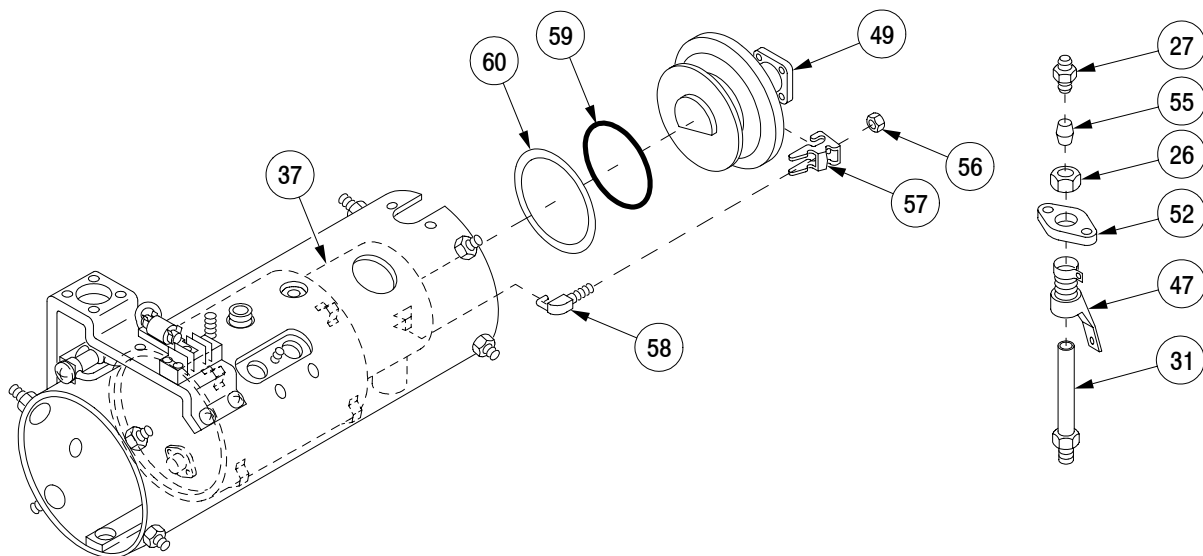

33ph023m

Section II. WINTERIZATION KIT COMPONENTS - CONTINUED

12-3 ENGINE COOLANT HEATER ASSEMBLY - CONTINUED

a. Disassembly - Continued

- 31 Remove four screws (61) and bracket (3) from housing (5).

NOTE

Note direction of arrow on diode so that it can be placed in its proper position during assembly.

- 32 Remove diode (62) from diode holder (63).
- 33 Remove screw (64), screw (65), and diode holder (63) from terminal strip (25).
- 34 Remove four screws (66), terminal strip (25), and marker strip (67) from bracket (3).
- 35 Remove nut (68) and bracket (69) with resistor motor (70) from bracket (3).
- 36 Remove nut (71), screw (72), and resistor (70) from bracket (69).
- 37 Remove two assembled nuts (73), two flat washers (74), restriction thermostat (7), and two spacers (75) from heat exchanger (37). Discard assembled nuts.
- 38 Remove three screws (76) from housing (5).
- 39 Spread housing (5) open and remove heat exchanger (37).

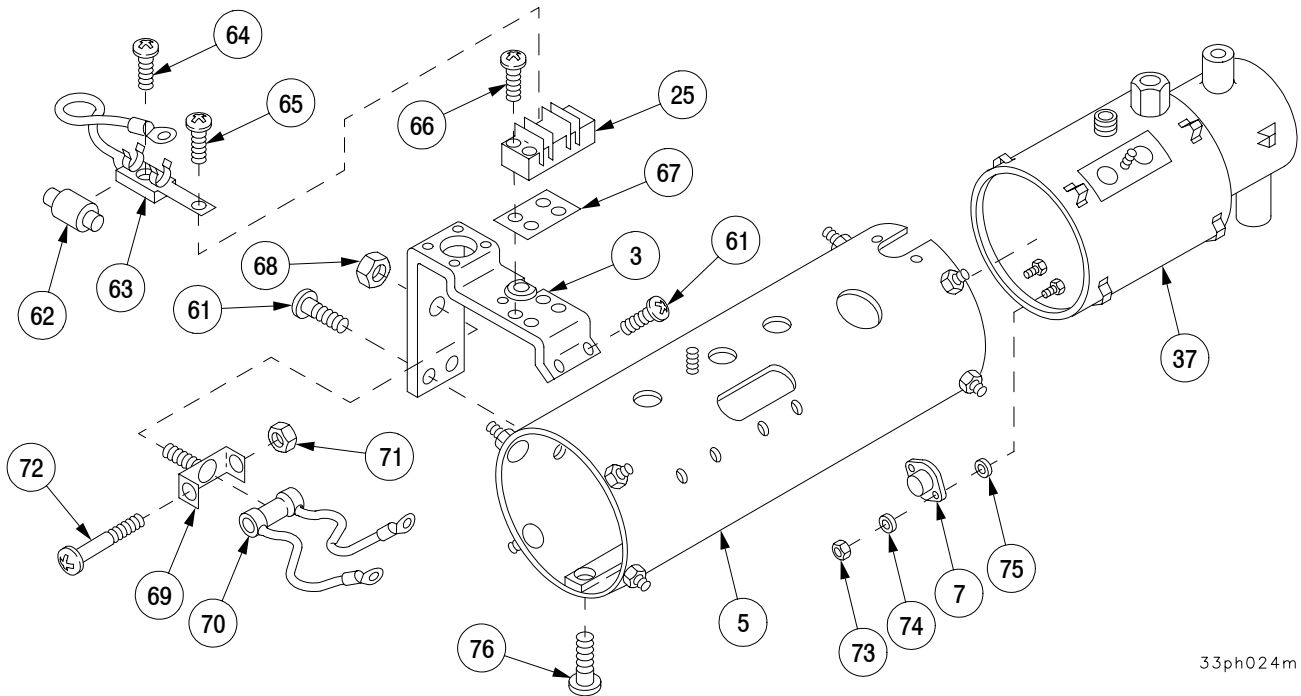

33ph024m

Section II. WINTERIZATION KIT COMPONENTS - CONTINUED

12-3 ENGINE COOLANT HEATER ASSEMBLY - CONTINUED

a. Disassembly - Continued**NOTE**

Perform step 40 only if nameplate requires replacement.

- 40 Remove four blind rivets (77) and nameplate (78) from housing (5). Discard blind rivets.
- 41 Remove two grommets (79) from housing (5).

b. Assembly.

- 1 Install two grommets (79) on housing (5).
- 2 Install nameplate (78) on housing with four new blind rivets (77), if removed.

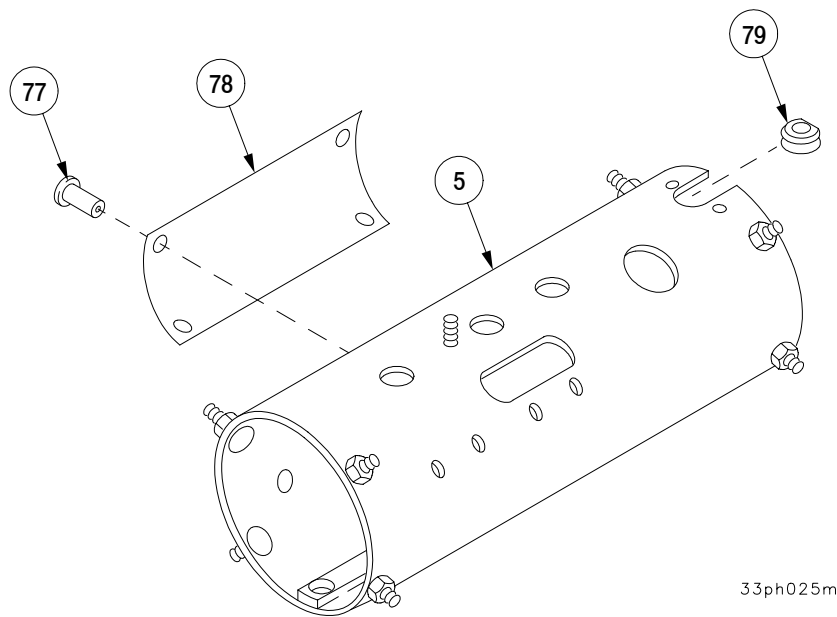

33ph025m

Section II. WINTERIZATION KIT COMPONENTS - CONTINUED

12-3 ENGINE COOLANT HEATER ASSEMBLY - CONTINUED

b. Assembly - Continued

- 3 Spread housing (5) open and install heat exchanger (37).
- 4 Install three screws (76) in housing (5).
- 5 Install two spacers (75), restriction thermostat (7), two flat washers (74), and two new assembled nuts (73) on heat exchanger (37).
- 6 Install resistor (70) on bracket (69) with screw (72) and nut (71).
- 7 Install resistor motor (70) and bracket (69) on bracket (3) with nut (68).
- 8 Install marker strip (67) and terminal strip (25) on bracket (3) with four screws (66).
- 9 Install diode holder (63) on terminal strip (25) with screw (64) and screw (65).
- 10 Install diode (62) on diode holder (63).
- 11 Install bracket (3) on housing (5) with four screws (61).

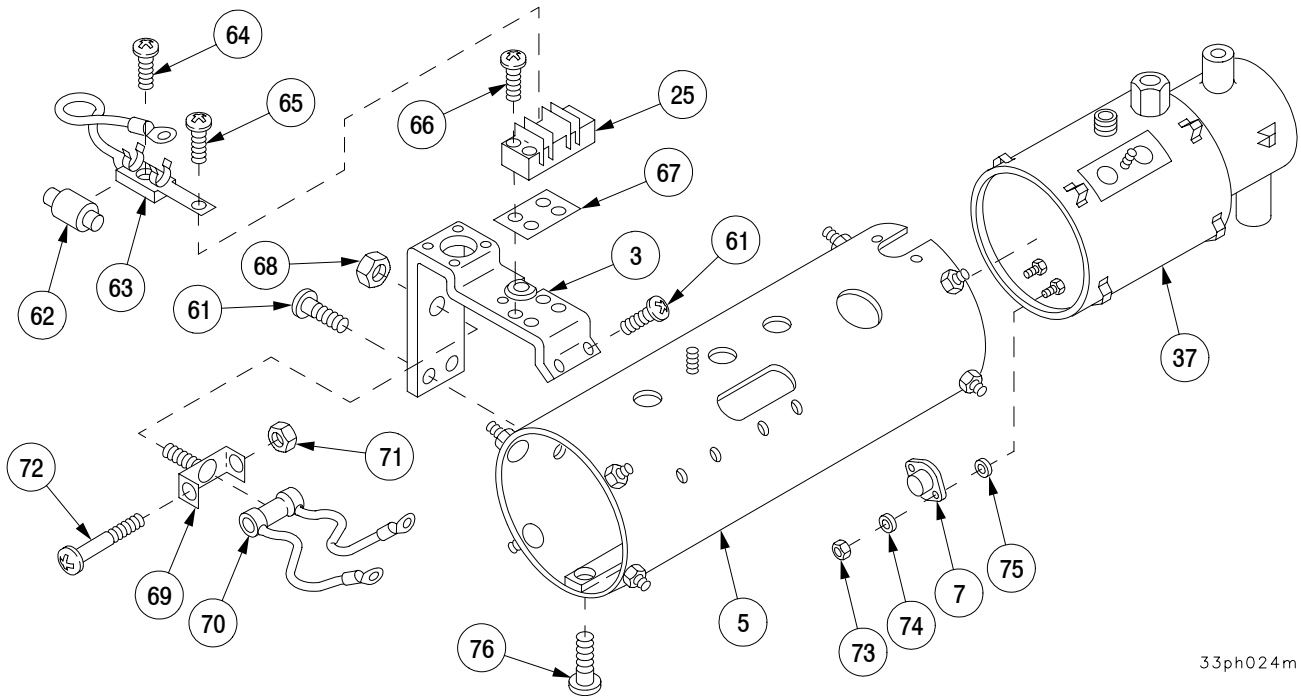

33ph024m

Section II. WINTERIZATION KIT COMPONENTS - CONTINUED

12-3 ENGINE COOLANT HEATER ASSEMBLY - CONTINUED

b. Assembly - Continued

- 12 Install burner assembly (49) in heat exchanger (37) with new gasket (60), and new preformed packing (59).
- 13 Secure burner assembly (49) to heat exchanger (37) with two clamps (57) and two nuts (56) on two hook bolts (58).
- 14 Install flange (52), resistor (47), nut (26), new compression fitting (55), and union (27) on fuel tube (31).

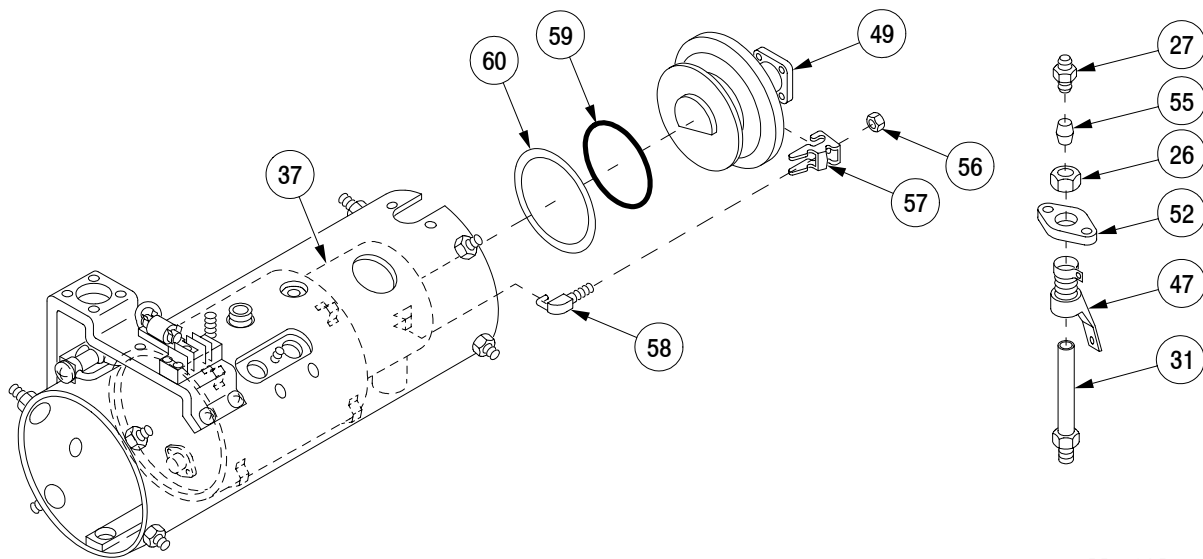

33ph023m

Section II. WINTERIZATION KIT COMPONENTS - CONTINUED

12-3 ENGINE COOLANT HEATER ASSEMBLY - CONTINUED

b. Assembly - Continued

- 15 Install fuel tube (31) and resistor (47) as an assembly on burner (49).
- 16 Install cable (18) on resistor (47) with two new assembled screws (53) and two nuts (54).
- 17 Install tapping plate (51).
- 18 Install two screws (50) onto tapping plate (51).
- 19 Install igniter (45) and new gasket (48) on burner assembly (49).
- 20 Install preheat resistor (47) on igniter (45) with two nuts (46).
- 21 Install lead (43) on igniter (45) with new assembled screw (42) and new lockwasher (44).
- 22 Install end plate (41) on housing (5) with four nuts (40).
- 23 Install new preformed packing (39), flat washer (38), connector (23), and overheat thermostat (9) on heat exchanger (37).
- 24 Install retainer (36) with new lockwasher (35), and nut (34) on heat exchanger (37).

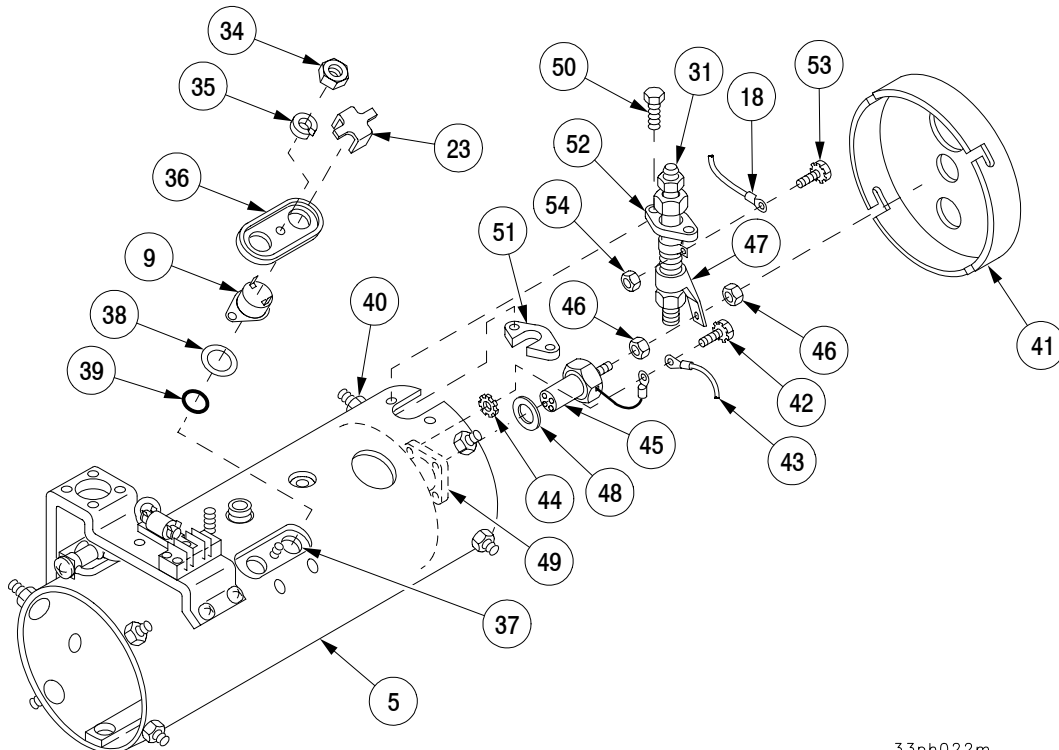

33ph022m

Section II. WINTERIZATION KIT COMPONENTS - CONTINUED

12-3 ENGINE COOLANT HEATER ASSEMBLY - CONTINUED

b. Assembly - Continued

- 25 Install lead (33) on overheat thermostat (9).
- 26 Install bracket (30) on housing (5) with two screws (32).
- 27 Install fuel control valve (28) on bracket (30) and tube (31) with two screws (29).
- 28 Install nut (26) on union (27) under fuel control valve (28).
- 29 Install lead (24) onto terminal strip (25).
- 30 Install two leads (21 and 22) on connector (23) on overheat thermostat (9).
- 31 Install nut (19) and new compression sleeve (20) on flame detector switch (12).
- 32 Install flame detector switch (12) and tighten nut (19).

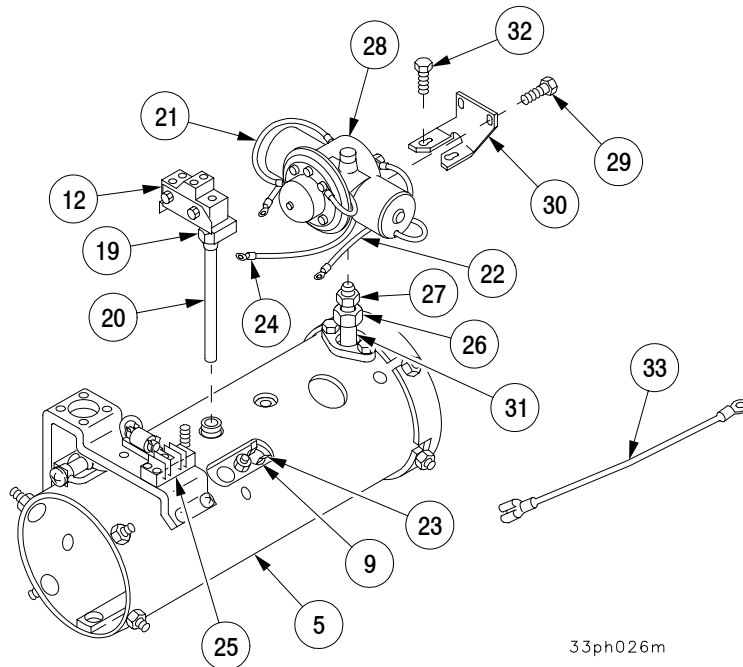

Section II. WINTERIZATION KIT COMPONENTS - CONTINUED

12-3 ENGINE COOLANT HEATER ASSEMBLY - CONTINUED

b. Assembly - Continued

- 33 Install three leads (16, 17, and 18) on flame detector switch (12) with five screws (15).
- 34 Position receptacle (2) with leads on heater assembly and install sleeve (14) over five receptacle leads (4, 6, 8, 10, and 11).
- 35 Connect leads (10 and 11) on flame detector switch (12).
- 36 Connect lead (8) to overheat thermostat (9).
- 37 Connect lead (6) to restriction thermostat (7).
- 38 Connect ground lead (4) to housing (5).
- 39 Install receptacle (2) on bracket (3) with four new assembled screws (1).
- 40 Secure five receptacle leads (4, 6, 8, 10, and 11) with three new tiedown straps (13).

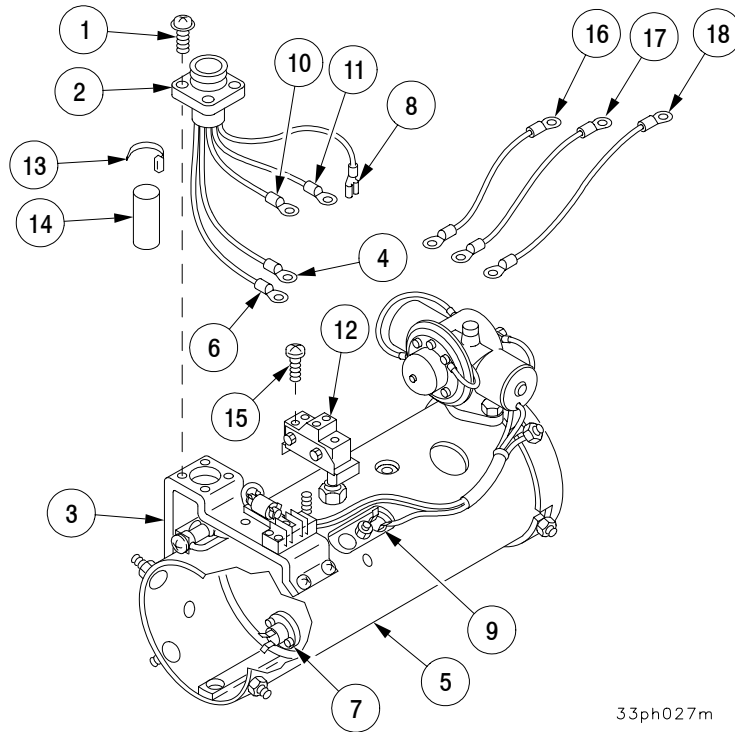

33ph027m

NOTE

FOLLOW-ON MAINTENANCE:
 Install blower motor assembly (para 12-2)
 Test engine coolant heater assembly (para 12-4)

Section II. WINTERIZATION KIT COMPONENTS - CONTINUED

12-4 ENGINE COOLANT HEATER ASSEMBLY TEST AND ADJUSTMENT.

This task covers: a. Fuel Flow Test and Adjustment b. Flame Detector Switch Adjustment

INITIAL SETUP

Tools

Fuel and electrical tool kit
 (SC 5180-95-B08)
 Suitable overflow container
 Cubic centimeter graduated laboratory cylinder
 (item 12, Appx F)

Equipment Conditions

Engine coolant heater assembly removed
 (TM 9-2350-314-20-1-2)

References

TM 9-2350-314-20-1-2

Materials/Parts

Electrical insulating varnish (item 14, Appx B)

a. Fuel Flow Test and Adjustment.

NOTE

Fuel control valve should always be tested after cleaning, and fuel flow should be tested when the heater has been repaired.

- 1 Connect the fuel control valve (1) to the fuel supply at the fuel control valve inlet port (2). Fuel supply should be off.

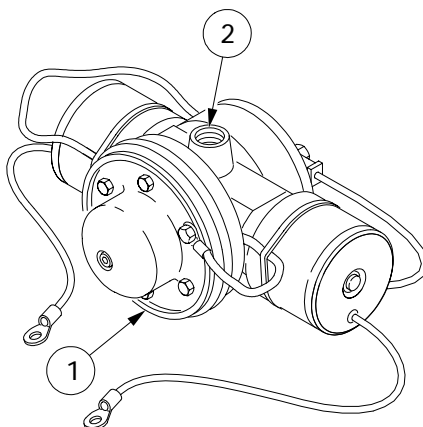

33ph028m

Section II. WINTERIZATION KIT COMPONENTS - CONTINUED

12-4 ENGINE COOLANT HEATER ASSEMBLY TEST AND ADJUSTMENT - CONTINUED

a. Fuel Flow Test and Adjustment - Continued

WARNING

A suitable container to catch overflow must be provided and precautions must be taken against the fire hazard of raw fuel to avoid possible severe injury or death.

- 2 Ground fuel control valve body (3) of fuel control valve (1) to a 24-volt power source and energize two solenoids (4 and 5) by placing two lead wires (6 and 7) in clip of positive wire connected to 24-volt source. This will open the two solenoids (4 and 5) and permit high heat fuel flow.
- 3 Turn fuel supply on and permit fuel flow into suitable overflow container to bleed fuel line and stabilize fuel flow.
- 4 After flow is stabilized, place graduated laboratory cylinder under fuel control valve outlet port (8) for exactly 1.0 minutes, then shut off fuel. Read contents of graduated laboratory cylinder at eye level. The contents must be within limits shown in Table 12-1 for high heat fuel flow. Refer to Table 12-2 for flow rate conversions not included in the chart.
- 5 Repeat steps 4 and 5 with only the shut-off solenoid (5) energized, using a 24-volt power source and restriction solenoid (4) deenergized. Fuel flow must be within limits noted for low heat fuel flow, as indicated in the fuel flow chart (Table 12-1). Refer to Fuel Flow Rate Conversion Chart (Table 12-2) for additional fuel flow rate conversions.
- 6 If flow rates are not within limits, adjust fuel control valve adjusting screw (9) clockwise to increase flow or counterclockwise to reduce flow. Adjust high heat flow first, then check low heat flow.

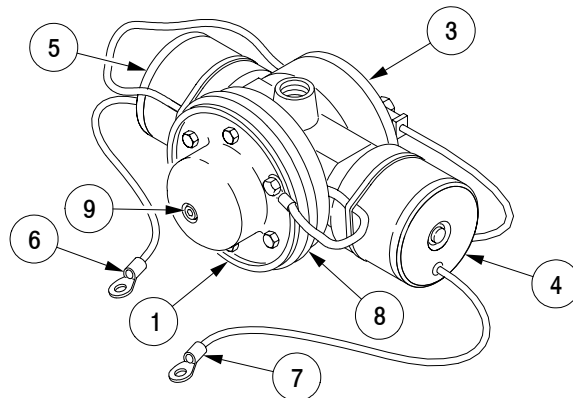

33ph029m

Section II. WINTERIZATION KIT COMPONENTS - CONTINUED

12-4 ENGINE COOLANT HEATER ASSEMBLY TEST AND ADJUSTMENT - CONTINUED

a. Fuel Flow Test and Adjustment - Continued

Table 12-1. Fuel Flow Chart.

	Fuel Rate LB/MIN	Fuel Rate in CC/MIN					
		DFA	DFI	Gasoline	JP4	CIE	Kerosene
High Heat	0.026 ± 0.004	14 ± 3	15 ± 3	16 ± 3	16 ± 3	15 ± 3	14 ± 3
Low Heat	0.015 ± 0.002	8.5 ± 2	8.5 ± 2	9 ± 2	9 ± 2	8.5 ± 2	8.5 ± 2

Table 12-2. Fuel Flow Rate Conversion

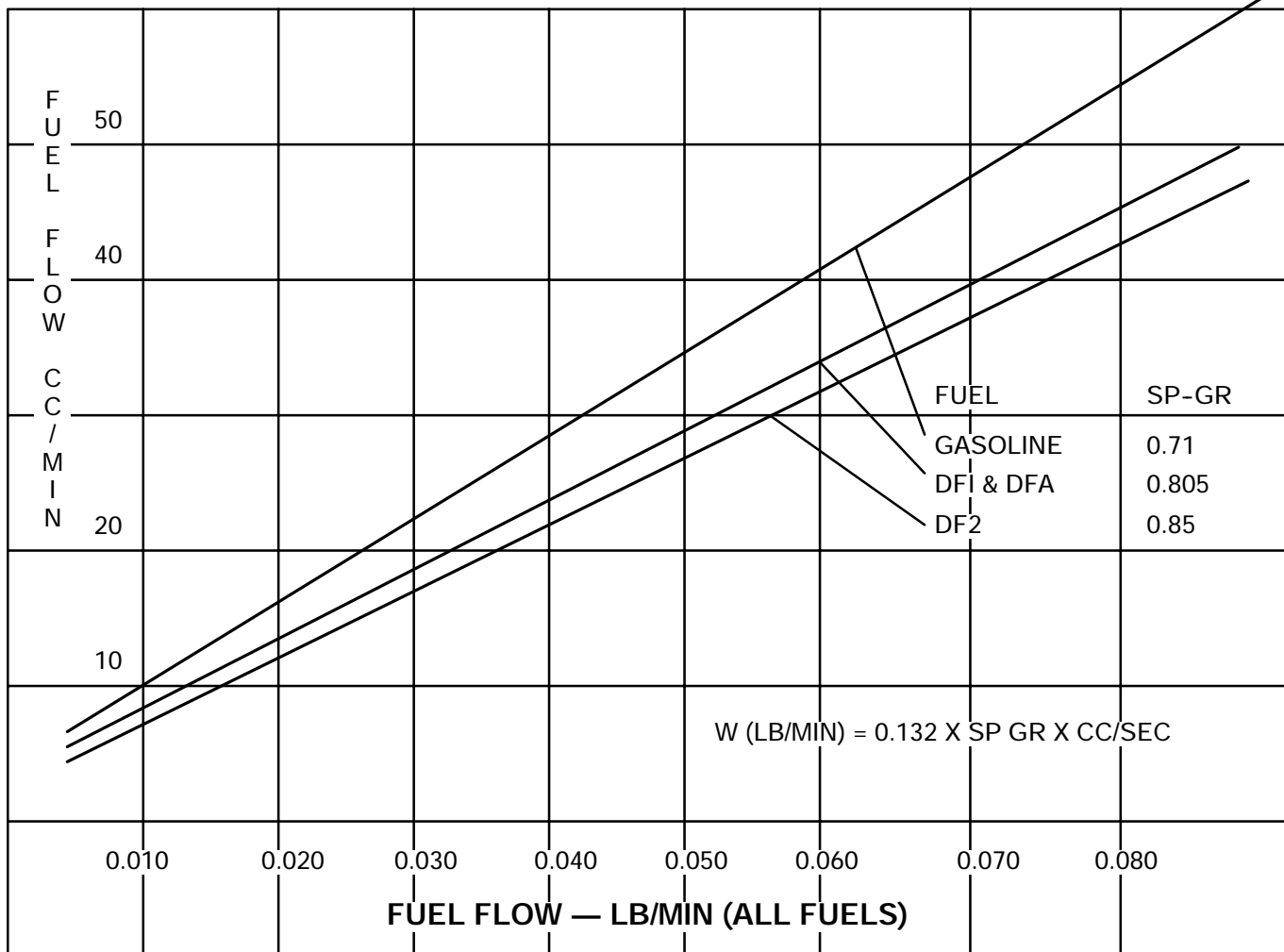

Section II. WINTERIZATION KIT COMPONENTS - CONTINUED

12-4 ENGINE COOLANT HEATER ASSEMBLY TEST AND ADJUSTMENT - CONTINUED

b. Flame Detector Switch Adjustment.

- 1 Rotate adjusting screw (1) several turns counterclockwise.
- 2 Rotate adjusting screw (1) clockwise until the microswitch (2) clicks, then turn adjusting screw (1) exactly three quarters of a turn.
- 3 Apply insulating varnish to adjusting screw (1).

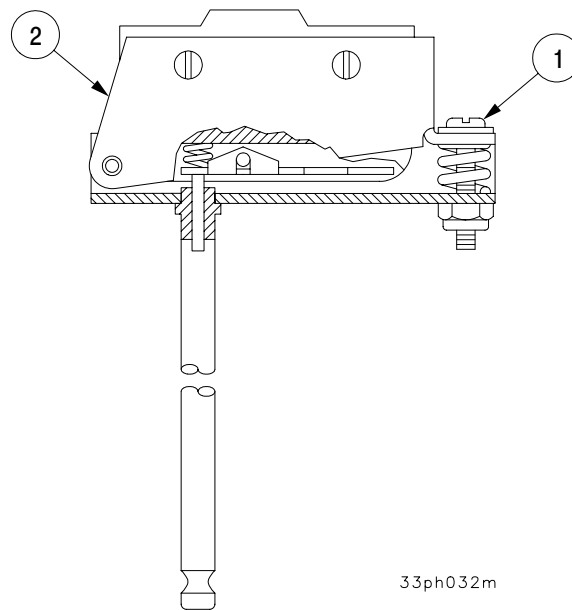

NOTE

FOLLOW-ON MAINTENANCE:
Install engine coolant heater assembly
(TM 9-2350-314-20-1-2)

Section II. WINTERIZATION KIT COMPONENTS - CONTINUED

12-5 HEATER CONTROL BOX AND BRACKET.

This task covers: a. Disassembly b. Assembly

INITIAL SETUP

Tools

General mechanic's tool kit
(SC 5180-90-N26)

Equipment Conditions

Heater control box remove
(TM 9-2350-314-20-1-2)

Materials/Parts

Lockwashers (2) (item 62, Appx E)
Lockwasher (item 63, Appx E)

References

TM 9-2350-314-20-1-2

a. Disassembly.

- 1 Remove lens (1) and lamp (2) from indicator assembly (3).
- 2 Remove nut (4) and lockwasher (5) from indicator assembly (3).
- 3 Remove nut (6) and lockwasher (7) from switch (8).
- 4 Remove nut (9) and lockwasher (10) from switch (11).
- 5 Remove two screws (12), two screws (13), switch panel (14), and panel (15) from case assembly (16).
- 6 Remove two nuts (17) from case assembly (16).
- 7 Remove two nuts (18), two lockwashers (19), two screws (20), and bracket (21) from case assembly (16). Discard lockwashers.

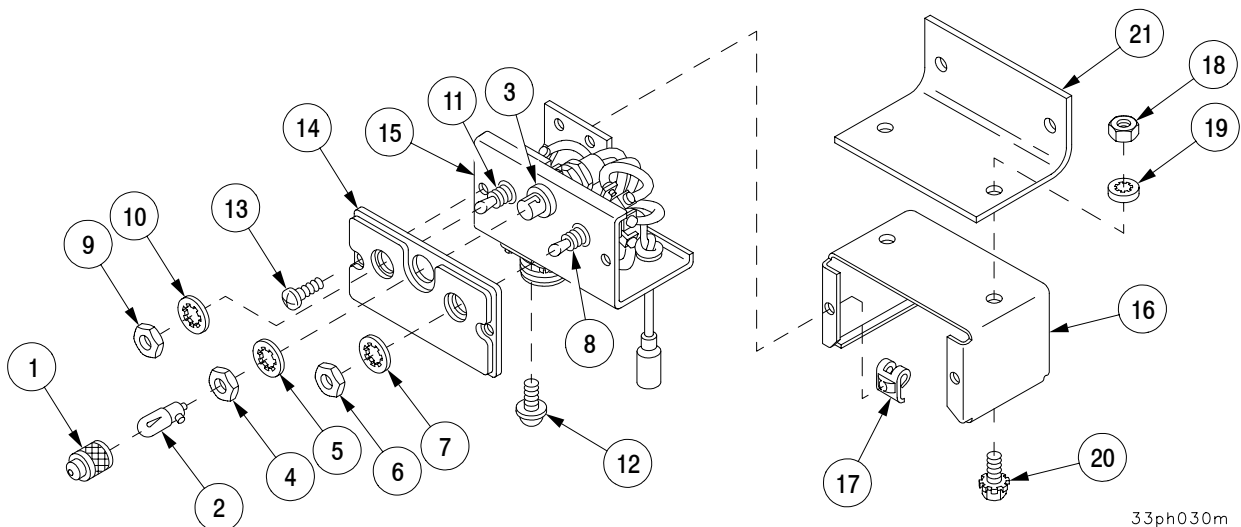

33ph030m

Section II. WINTERIZATION KIT COMPONENTS - CONTINUED

12-5 HEATER CONTROL BOX AND BRACKET - CONTINUED

a. Disassembly - Continued

NOTE

Tag all electrical connections and electrical leads prior to removal to aid installation.

- 8 Remove nut (22), lockwasher (23), lead (24), two screws (25), and circuit breaker (26) from panel (15). Discard lockwasher.
- 9 Remove three leads (24) and indicator assembly (3).
- 10 Remove lead (27).
- 11 Remove lead (28).
- 12 Disconnect five leads (29).
- 13 Remove four screws (30), receptacle assembly (31), and bracket (32) from panel (15).
- 14 Remove lead (33) and grommet (34) from panel (15).
- 15 Remove slotted washer (35) and electrical shell (36) from lead (33).
- 16 Remove switch (8) and flat washer (37) from panel (15).
- 17 Remove retaining plate (38) and jumper assembly (39) from switch (8).
- 18 Remove switch (11) and flat washer (40) from panel (15).

b. Assembly.

- 1 Install flat washer (40) on switch (11).
- 2 Install jumper assembly (39) and retaining plate (38) on switch (8).
- 3 Install flat washer (37) on switch (8).
- 4 Install electrical shell (36) and slotted washer (35) on lead (33).
- 5 Install grommet (34) and lead (33) on panel (15) and connect lead (33).
- 6 Install bracket (32) and receptacle assembly (31) on panel (15) with four screws (30).
- 7 Install five leads (29).
- 8 Install lead (28).

Section II. WINTERIZATION KIT COMPONENTS - CONTINUED

12-5 HEATER CONTROL BOX AND BRACKET - CONTINUED

b. Assembly - Continued

- 9 Install lead (27).
- 10 Install indicator assembly (3) and connect three leads (24).
- 11 Install circuit breaker (26) on panel (15) with two screws (25), lead (24), new lockwasher (23), and nut (22).

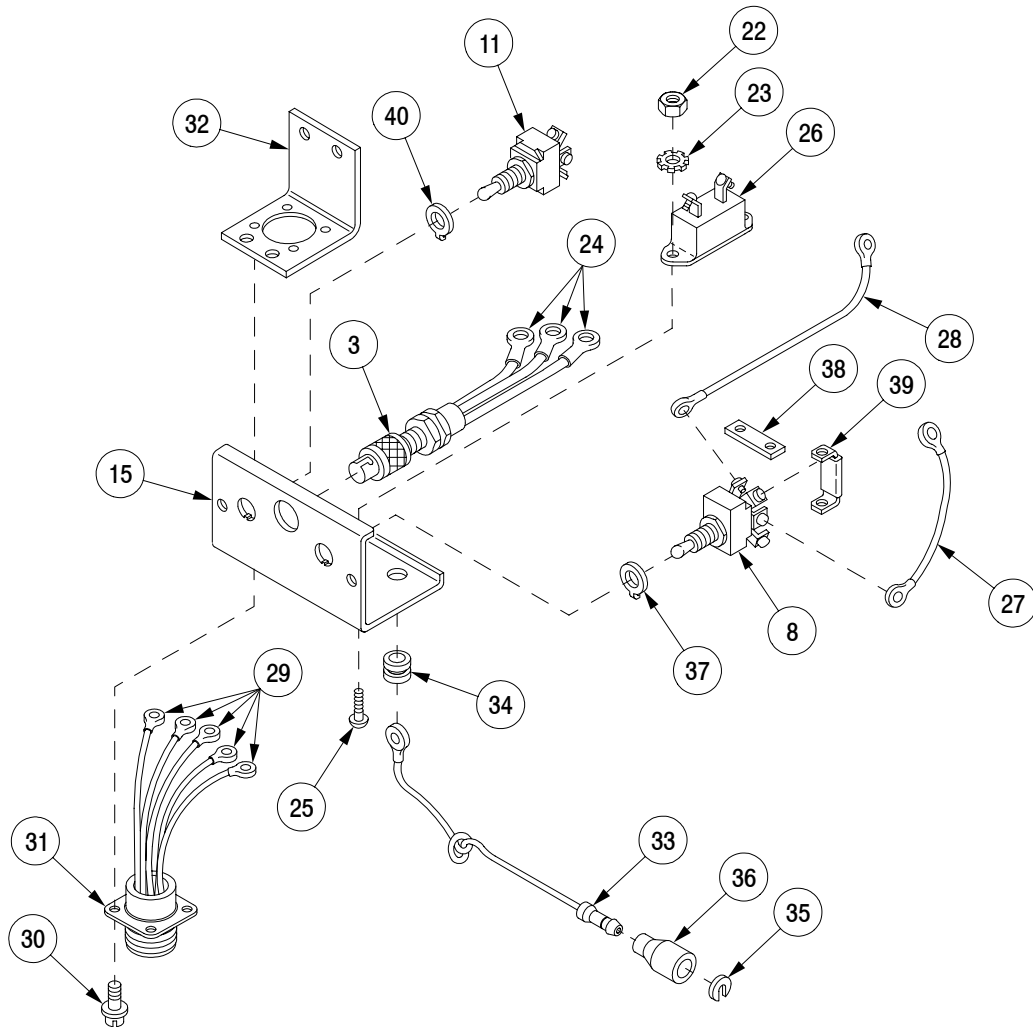

33ph031m

Section II. WINTERIZATION KIT COMPONENTS - CONTINUED

12-5 HEATER CONTROL BOX AND BRACKET - CONTINUED

b. Assembly - Continued

- 12 Install bracket (21) to case assembly (16) with two screws (20), two new lockwashers (19), and two nuts (18).
- 13 Install two nuts (17) on case assembly (16).
- 14 Install lockwasher (10), nut (9), and switch (11) in panel (15) and switch panel (14).
- 15 Install lockwasher (7), nut (6), and switch (8) in panel (15) and switch panel (14).
- 16 Install lockwasher (5), nut (4), and indicator assembly (3) in panel (15) and switch panel (14).
- 17 Install lamp (2) and lens (1) on indicator assembly (3).
- 18 Install panel (15) and switch panel (14) to case assembly (16) with two screws (13) and two screws (12).

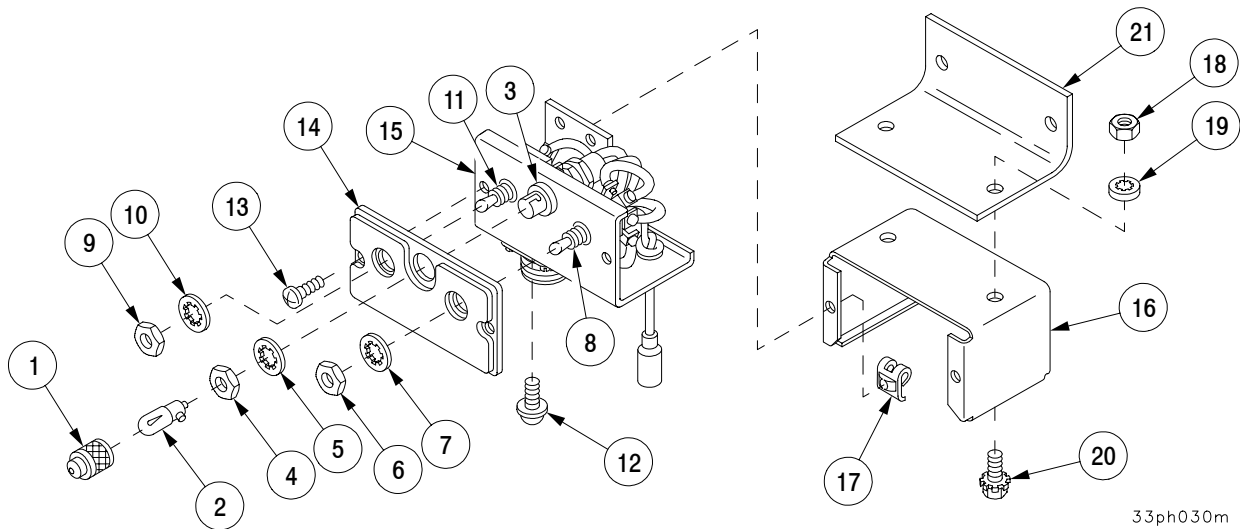

NOTE

FOLLOW-ON MAINTENANCE:

Install heater control box
(TM 9-2350-314-20-1-2)

Section III. VENTILATION KIT INSTALLATION

12-6 VENTILATION KIT.

This task covers: a. Removal b. Installation

INITIAL SETUP

Tools

General mechanic's tool kit
(SC 5180-90-N26)

References

TM 9-2350-314-20-1-2

Materials/Parts

Ventilation kit (item 7, Appx E)

WARNING

Ventilation kit is installed only during periods of extended storage or transportation. Operation of vehicle with ventilation kit installed may allow foreign material to enter the vehicle causing injury to personnel or damage to equipment.

NOTE

Two different shapes of ventilation screens are provided in the ventilation kit. The square screen does not require the use of spacers and mounts using four screws; the triangular screens require spacers and mounts using three screws.

Section III. VENTILATION KIT INSTALLATION - CONTINUED

12-6 VENTILATION KIT - CONTINUED

a. Removal.

- 1 Remove screws (1), flat washers (2), spacers (3), screen retainer (4), and screen (5).
- 2 Install hull subfloor access covers (TM 9-2350-314-20-1-2).

b. Installation.

NOTE

Hull subfloor access covers must be stored with vehicle upon removal.

- 1 Remove hull subfloor access covers (TM 9-2350-314-20-1-2).

NOTE

Be sure that hull drains are clear of debris prior to installing ventilation kit.

- 2 Install screen (5), screen retainer (4), and spacer (3) on hull with flat washers (2) and screws (1).

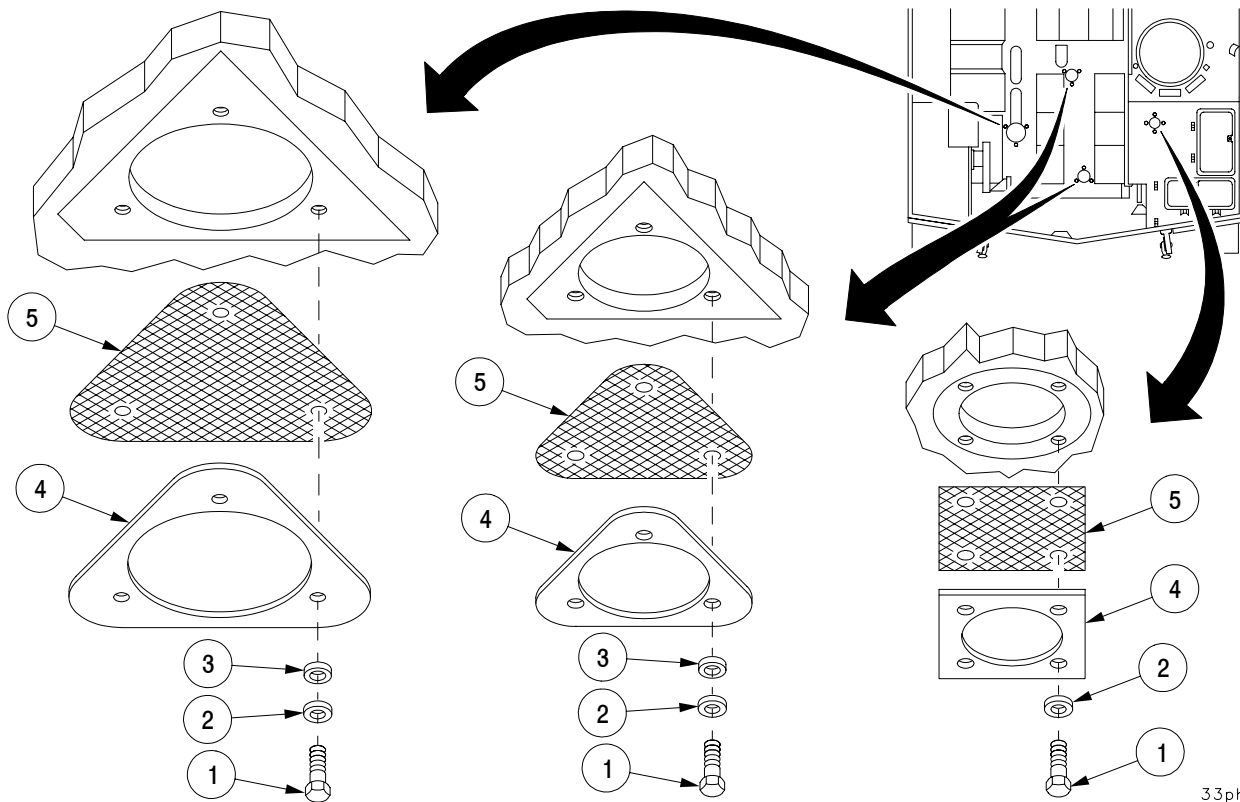

33ph033m

CHAPTER 13

TOWING ATTACHMENTS

GENERAL

This chapter illustrates and defines the direct support procedures for removal and installation of towing eyes.

CONTENTS

Page

TOWING EYE REPLACEMENT	13-2
------------------------------	------



TOWING EYE REPLACEMENT.

This task covers: a. Removal b. Installation

INITIAL SETUP

Tools

Welding shop, trailer-mounted (item 54, Appx F)
Sander disc, electric (item 38, Appx F)

Equipment Conditions

Vehicle parked on level ground
(TM 9-2350-314-10)
Towing eye bushing removed
(TM 9-2350-314-20-1-2)

References

TM 9-2350-314-10
TM 9-2350-314-20-1-2
TM 9-237

a. Removal.

WARNING

Wear chip-guarding and personal protective equipment (goggles/shield, gloves, etc.) when using grinder. Failure to heed this warning may result in severe injury to personnel.

NOTE

There are two towing eyes; they are replaced the same way.

Grind weld loose to remove towing eye (1) from front surface of vehicle (2).

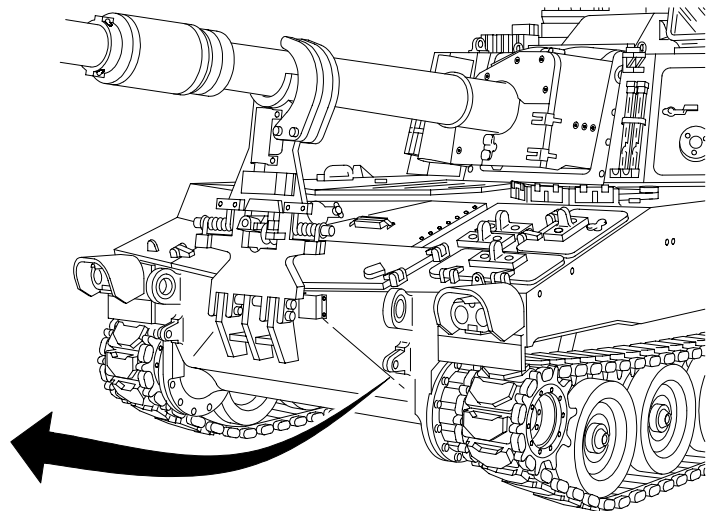
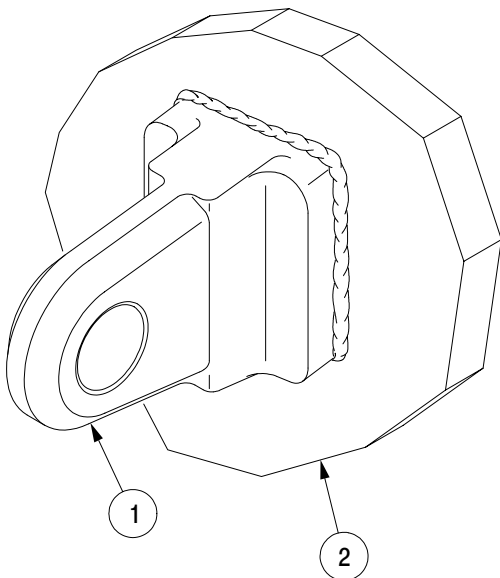

15ph002m

13-2 TOWING EYE REPLACEMENT - CONTINUED

b. Installation.

- 1 Position towing eye (1) into recess on front surface of vehicle (2).

WARNING

Unsafe welding practices can cause serious injury from fire, explosions, or harmful agents. Allow only authorized personnel to weld metals, and follow the precautions in TM 9-237. Protective clothing and goggles must be worn; adequate protective equipment must be used; a suitable fire extinguisher must be kept nearby; and the requirements of TM 9-237 must be strictly followed.

- 2 Weld towing eye (1) to front surface of vehicle (2) with aluminum armor weld type A, per MIL-STD-1946. Weld should be 3/4 in. and go completely around towing eye (1).

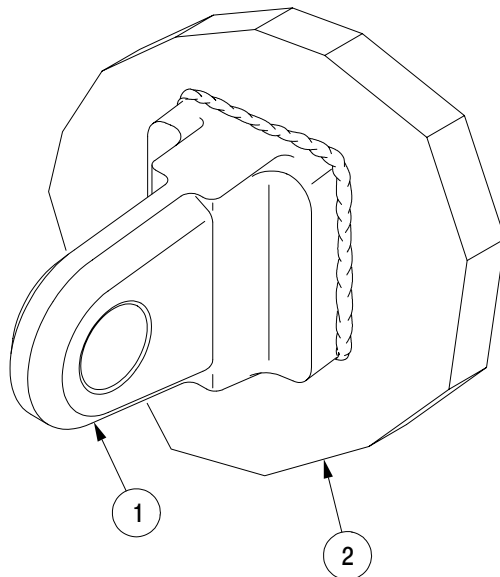

15ph002ma

NOTE

FOLLOW-ON MAINTENANCE:
Install towing eye bushing
(TM 9-2350-314-20-1-2)

APPENDIX A REFERENCES

A-1 SCOPE.

The following publications are applicable at unit, direct support and general support maintenance level to materiel covered in this technical manual. Appropriate indexes should be consulted frequently for latest applicable changes, revisions and additions.

A-2 FORMS.

Recommended Change to Publications	DA Form 2028
Recommended Change to Equipment Technical Manuals	DA Form 2028-2
Accident Report	DA Form 285
Quality Deficiency Report	SF Form 368

A-3 FIELD MANUALS.

First Aid for Soldiers	FM 21-11
NBC Equipment	FM 3-3
NBC Protection	FM 3-4
NBC Decontamination	FM 3-5

A-4 TECHNICAL BULLETINS.

Solder and Soldering	TB SIG 222
Occupational and Environmental Health: Hearing Conservation	TB MED 501
Reconditioning of Type I and Type II Reuseable Metal Containers	TB 9-289
Painting Instructions for Army Materiel	TB 43-0147

A-5 TECHNICAL MANUALS.

Storage, Shipment, Handling, and Disposal of Chemical Agents and Hazardous Chemicals	TM 3-250
Inspection, Care, and Maintenance of Anti-Friction Bearings	TM 9-214
Operator's Manual, Welding Theory, and Application	TM 9-237
Materials Used for Cleaning, Preserving, Abrading, and Cementing Ordnance Materiel; and Related Materials Including Chemicals	TM 9-247
General Maintenance Procedures for Fire Control Materiel	TM 9-254
Operator's Manual: Howitzer, Self-Propelled: 155MM, M109A6	TM 9-2350-314-10
Unit Maintenance Manual for Hull Systems and Components of Howitzer, Medium, Self-Propelled: 155mm, M109A6	TM 9-2350-314-20-1-1
.....	TM 9-2350-314-20-1-2
Unit Maintenance Manual for Cab Systems and Components of Howitzer, Medium, Self-Propelled: M109A6	TM 9-2350-314-20-2-1
.....	TM 9-2350-314-20-2-2
Unit, Direct Support, and General Support Maintenance Repair Parts and Special Tools List for Hull Associated Components of Howitzer, Medium, Self-Propelled: 155MM, M109A6	TM 9-2350-314-24P-1
Direct Support and General Support Maintenance Manual for Cab Systems and Components of Howitzer, Medium, Self-Propelled: 155mm, M109A6	TM 9-2350-314-34-2

A-5 TECHNICAL MANUALS - CONTINUED

Field and Depot Maintenance Manual for Power Train Assembly
 (Allison Model XTG-411 2A/-4). Composed of Transfer Assembly,
 Transmission Input (2520-00-894-9535 and 2520-01-282-1228);
 Transmission Assembly (2520-00-894-9533 and 2520-01-281-1224),
 Drive Assembly; Transmission Output, Vehicle Left (2520-00-894-9534);
 Drive Assembly, Transmission Output, Vehicle Right (2520-00-894-9532) . . . TM 9-2520-234-35

Organizational, Direct Support, and General Support Maintenance Manual
 (including Repair Parts and Special Tools Lists) for Combat Vehicle
 Personnel Heaters. Hupp MF 510A, Multi-Fuel, 6000 BTU, NSN
 2540-00-930-8938. Hupp MF 510B, Multi-Fuel, 6000 BTU,
 NSN 2540-01-071-0652. Stewart Warner 10560C, Multi-Fuel, 6000 BTU,
 NSN 2540-01-083-0691. Stewart Warner 10560M, Multi-Fuel, 6000 BTU,
 NSN 2540-01-071-0651. Stewart Warner 8460-C24, Multi-Fuel,
 2540-00-854-4449, ESPAR Products V7S, Diesel, 40,000 BTU,
 NSN 2540-01-114-7688 TM 9-2540-205-24&P

Direct Support and General Support Maintenance for Engine, Diesel
 with Container 7083-7391 (NSN 2815-01-335-4579) Engine, Diesel with
 Container Model 7083-7395 (NSN 2815-01-043-7092) (NSN
 2815-01-260-0211) Engine, Diesel with Container Model 7083-7396
 (NSN 2815-01-040-3120) (NSN 2815-01-260-0212) Engine, Diesel with
 Container Model 7083-7398 (NSN 2815-00-936-7695) Engine, Diesel
 with Container Model 7083-7399 (NSN 2815-00-134-4845) TM 9-2815-202-34

Direct Support, General Support and Depot Maintenance Manual (Including
 Repair Parts) for Starter, Engine, Electrical Assembly
 (NSN 2920-00-226-6545) (Delco-Remy Model 1113943)
 (Military Part No. 10911018-1), Starter, Engine, Electrical Assembly
 (2920-00-911-5637) (Delco-Remy Model 1113904)
 (Military Part No. 10911018), Starter, Engine, Electrical Assembly
 (2920-00-912-9510) (Delco-Remy Model 1113944) TM 9-2920-242-35

Direct Support and General Support Maintenance Manual (including RPSTL)
 for Starter, Engine, Electric Assembly (Leece-Neville M001072MB)
 (NSN 2920-00-267-9987) TM 9-2920-243-34

Direct Support, General Support, and Depot Maintenance (including
 Repair Parts) for Starter, Engine, Electrical Assembly
 (NSN 2920-00-999-6216) (Prestolite Model MFY6101IUT) TM 9-2920-248-35

Operator's, Organizational, Direct Support, and General Support
 Maintenance Manual Including Repair Parts List for Welding Shop, Trailer
 Mounted Model 491996 (NSN 3431-01-090-1231) TM 9-3431-265-14&P

Operator's, Organizational, Direct Support, and General Support
 Maintenance Manual for Lead-Acid Storage Batteries TM 9-6140-200-14

Procedure for Destruction of Improved Conventional Munitions to Prevent
 Enemy Use TM 43-0002-33

Painting Instructions for Field Use TM 43-0139

Destruction of Conventional Ammunition to Prevent Enemy Use TM 750-244-5-1

Procedures for Destruction of Tank-Automotive Equipment to Prevent
 Enemy Use TM 750-244-6

Cooling Systems: Tactical Vehicles TM 750-254

A-6 REGULATIONS.

Reporting of Product Quality Deficiencies Across Component Lines AR 702-7
 Accident Reporting and Records AR 385-40

A-7 MILITARY SPECIFICATIONS.

Welding Repair of Steel Castings (Other Than Armor) Metal-Arc, Manual MIL-STD-1943
 Welding, Gas Metal-Arc and Gas Tungsten-Arc, Aluminum Alloys,
 Readily Weldable for Structures, Excluding Armor MIL-STD-372

A-8 MISCELLANEOUS PUBLICATIONS.

Army Medical Department Expendable/Durable Items CTA 8-100
 Expendable Items (except Medical, Class V, Repair Parts, and
 Heraldic Items) CTA 50-970
 The Army Maintenance Management System (TAMMS), as contained
 in Maintenance Management Update DA PAM 738-750
 Sets, Kits, Outfits, and Tools Shop Equipment, Machine Shop: Field
 Maintenance Basic (NSN 3470-00-754-0708) SC 3470-95-A02
 Shop Equipment, Welding; Field Maintenance, SC 3470-95-A08
 Sets, Kits, and Outfits Shop Equipment, Automotive Maintenance and
 Repair for Field Maintenance, Basic, Less Power
 (NSN 4910-00-754-0705) SC 4910-95-A31
 Sets, Kits, Outfits, and Tools, Shop Equipment Automotive Maintenance,
 and Repair; Field Maintenance, Supplemental No. 1, Less Power
 (NSN 4910-00-754-0706) and Shop Equipment Automotive Maintenance
 and Repair: Field Maintenance, Supplemental No. 1 MAP Only
 (NSN 4910-00-919-0078) SC 4910-95-A62
 Shop Equipment, Field Maintenance, #2 Supplemental
 (NSN 4910-00-754-0707) SC 4910-95-A63
 Sets, Kits, and Outfits, Components Lists for Tool Set, Vehicle Full-Track:
 Organizational Maintenance No. 2, Less Power (NSN 4940-00-754-0743)
 and MAP Only (NSN 4940-00-919-0106) SC 4940-95-A08
 Sets, Kits, and Outfits, Components List Shop Equipment, Fuel and Electrical
 System Engine: Field Maintenance, Basic, Less Power (NSN 4910-00-754-0714)
 (T30414) and Shop Equipment, Fuel and Electrical System Engine: Field
 Maintenance, Basic, MAP Only (NSN 4910-00-919-0083) SC 4940-95-B20
 Sets, Kits, and Outfits Tool Kit, General Mechanic's Automotive (GMTK)
 (NSN 5180-00-177-7033) SC 5180-90-N26
 Sets, Kits, and Outfits, Components List Tool Kit, Electronic Equipment,
 TK-105/G (NSN 5180-00-610-8177) SC 5180-91-R07
 Sets, Kits, and Outfits, Component Lists Tool Kit, Artillery and Turret
 Mechanic's Ordnance (NSN 5180-00-357-7727) SC 5180-95-A12
 Sets, Kits, and Outfits, Components List Tool Kit, Automotive Fuel and
 Electrical System Repair (NSN 5180-00-754-0655) SC 5180-95-B08

APPENDIX B

EXPENDABLE AND DURABLE ITEMS LIST

Section I. INTRODUCTION

B-1 SCOPE.

This appendix lists expendable and durable items you will need to maintain the M109A6 hull. This listing is for informational purposes only and is not authority to requisition the listed items. These items are authorized to you by CTA 50-970, expendable items (except Medical, Class V, Repair Parts, and Heraldic Items).

B-2 EXPLANATION OF COLUMNS.

a. Column (1) - Item number. This number is assigned to the entry in the listing for referencing when required.

b. Column (2) - Level. This column identifies the lowest level of maintenance that requires the listed item.

C - Operator/Crew

O - Unit Maintenance

F - Direct Support Maintenance

H - General Support Maintenance

c. Column (3) - National Stock Number. This is the national stock number assigned to the item; use it to request or requisition the item.

d. Column (4) - Description. Indicates the federal item name and, if required, a description to identify the item. The last line for each item indicates the Commercial and Government Entity Code (CAGEC) in parentheses followed by the part number.

e. Column (5) - Unit of Measure (U/M)/Unit of Issue (U/I). This measure is expressed by a two-character alphabetical abbreviation (e.g., EA, IN, PR). If the unit of measure differs from the unit of issue as shown in the Army Master Data File (AMDF), requisition the lowest unit of issue that will satisfy your requirements.

Section II. EXPENDABLE AND DURABLE ITEMS

(1) Item Number	(2) Level	(3) National Stock Number	(4) Description	(5) (U/M)/ (U/I)
1	O	8040-00-664-4318	Adhesive, 1 PT can: (81348) MMM-A-1617	PT
2	F	8040-00-701-9546	Adhesive, 1 kit: (80244) MIL-A-46106GP1TY1	KT
3	F	8040-00-118-2695	Adhesive, Type I, 1 kit: (80244) MIL-A-46146 TY1	KT
3.1	F	8040-01-147-9957	Adhesive, 12347278 (19207)	KT
4	F	8105-00-299-8532	Bag, Plastic; 100 each: (58536) A-A-1668	BX
5	F	8115-00-190-5020	Box, Shipping; 10 each: (81348) PPP-B-636	BD
6	O	7920-00-514-2417	Brush, Acid Swabbing, 1 Gross: (81348) H-B-643	GR
7	F	5350-00-268-3116	Cloth, Abrasive, 50 YD roll: (81348) P-C-458	RO
8	F	8010-01-193-0519	Coating, Primer: (81349) MIL-P-53030	KT
9	F	7930-00-530-8067 7930-00-527-1207	Detergent, General Purpose: (80244) P-D-220TY2 1 GL can 5 GL can	GL CN
10	F	3439-00-400-1972	Flux, Soldering, 4 OZ: (81349) MIL-F-14256	BT
11	F	6515-01-150-2976 6515-01-150-2978 6515-01-150-2977	Gloves, Patient, Exam, 100 each: (89875) E-010 Size Small E-012 Size Medium E-011 Size Large	PG
12	O	9150-00-985-7246 9150-00-985-7247 9150-00-985-7248	Grease, Aircraft: (81349) MIL-G-23827 1-3/4 LB can 6-1/2 LB can 35 LB can	CN CN CN
13	O	9150-01-197-7693 9150-01-197-7690 9150-01-197-7689	Grease, Automotive: (81349) MIL-PRF-10924 14 OZ cartridge 1-3/4 LB can 6-1/2 LB can	CA CN CN
14	F	5970-00-161-7422	Insulating Varnish, Electrical, 1 GL can: (24446) Glyptal1201RED	GL
15	O	9150-00-189-6727 9150-00-186-6668	Lubricating Oil: (81349) MIL-L-2104 1 QT can 5 GL can	QT CN
16	O	9150-00-186-6681 9150-00-188-9858	Lubricating Oil: (81349) MIL-PRF-2104 1 QT can 5 GL can	QT CN
17	O	5510-00-962-7141	Lumber, 4X4X12: (81348) MM-L-736	EA

Section II. EXPENDABLE AND DURABLE ITEMS

(1) Item Number	(2) Level	(3) National Stock Number	(4) Description	(5) (U/M)/ (U/I)
18	F	8010-00-401-7056	Paint, Fire Retardant, 1 GL can: (85321) SAF707	GL
19	F	5350-00-598-5537	Paper, Abrasive: (80244) A-A-1202 TY1SZFINE	HD
20	F	8010-00-551-0128	Pigment, Iron-Blue, 2 OZ tube: (81348) TT-P-381	TU
21	C	7920-00-205-1711	Rag, Wiping, 50 LB bale: (58536) A-A-2522	BE
22	F	2910-00-078-4065	Repair Kit, Plastic, 1 kit: (19207) 10941900	EA
23	F	8040-01-108-6660	Repair Kit, Fiberglass, 1 kit: (73168) 900M-195	KT
24	O	8030-00-965-2438	Sealing Compound, 60 FT roll: (81349) MIL-S-11030	RO
25	O	8030-00-081-2333 8030-00-823-7917	Sealing Compound: (81349) MIL-S-22473 10 CC bottle (10 each) 50 CC bottle	BT BT
26	O	8030-00-081-2336	Sealing Compound, 50 CC bottle: (81349) MIL-S-22473 GRAV	BT
27	H	8030-00-220-6973	Sealing Compound, 4 OZ can: (81349) MIL-S-45180 TY3	CN
27.1	F	8030-00-163-5792	Sealing Compound (19207) 11663357 30 CC bottle	BT
28	O	3439-00-133-1108	Solder, Lead, 1 LB spool: (81348) QQ-S-5T1	SL
29	O	6850-00-281-3061 6850-00-274-5421	Solvent, Dry-cleaning: (81348) P-D-680 4 OZ can 5 GL can	CN CN
30	O	5970-00-419-4291	Tape, Insulation, 108 FT roll: (81349) MIL-I-24391	RO
31	F	7510-01-146-7767	Tape, Pressure Sensitive, 60 YD roll: (81348) PPP-T-60	RO
32	F	6810-00-682-6867	Water, Distilled: (81346) ASTM D 1193	BX
33	O	8030-00-889-3535	Tape, Antiseizing, 260 IN. spool: (81349) MIL-T-27730	EA
34	O	6850-00-177-5094	Silicone Compound 8 OZ tube: (81343) SAE AS8660	TU

APPENDIX C

ILLUSTRATED LIST OF MANUFACTURED ITEMS

C-1 SCOPE.

This appendix includes complete instructions for making items authorized to be manufactured or fabricated at DS and GS maintenance level. A part number index in alphanumeric order is provided for cross-referencing the item to be manufactured to the figure which covers fabrication criteria. All bulk materials needed for manufacture of an item are listed by part number or specification number in a tabular list on the illustration.

C-2 PART NUMBER INDEX LIST.

<u>ITEM</u>	<u>PART NUMBER</u>	<u>REFERENCE</u>
Workstand, Final Drive	MI015	Figure 1
Bracket, Fabricated, Fan Drive	MI016	Figure 2
Stand, Powerpack	—	Figure 3

C-3 MANUFACTURED ITEMS.

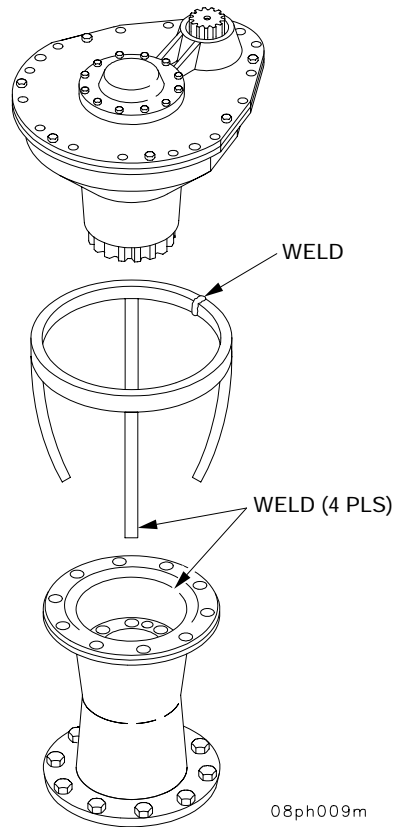

WARNING

Workstand must be secured to floor or platform before using. If not secured, workstand may tip over causing injury to personnel or damage to equipment.

Procedure:

- 1 Cut one piece of 1/8 in. steel to fit around final drive. Weld piece to form a circle as shown.
- 2 Cut four pieces of steel and weld one end to circle and the other ends to sprocket hub as shown.

MATERIALS	
DESCRIPTION	NSN/SPECIFICATION
SPROCKET, HUB	2520-00-066-0239
1/8-IN. FLAT STEEL X 2.5-IN. WIDE	SPEC ASTM-A-366

Figure 1. Workstand, Final Drive (MI015)

C-3 MANUFACTURED ITEMS - CONTINUED

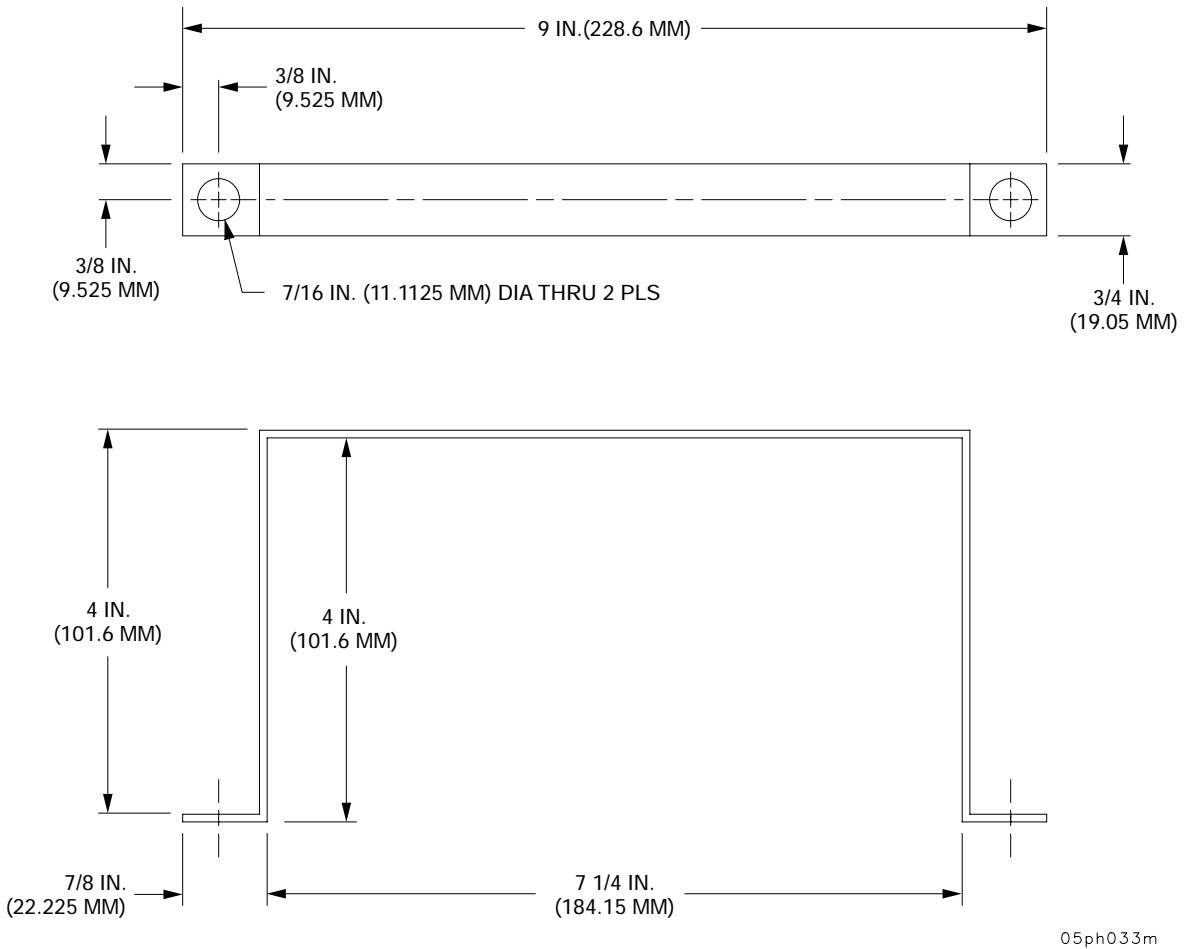

NOTE

All dimensions are shown in inches (millimeters).

Procedure:

- 1 Cut metal as shown.
- 2 Shape as shown.
- 3 Drill holes as shown.

MATERIALS	
DESCRIPTION	NSN/SPECIFICATION
3/4-IN. WIDE X 0.080-IN. THICK STEEL	SPEC ASTM-A-366

Figure 2. Bracket, Fabricated, Fan Drive (MI016)

C-3 MANUFACTURED ITEMS - CONTINUED

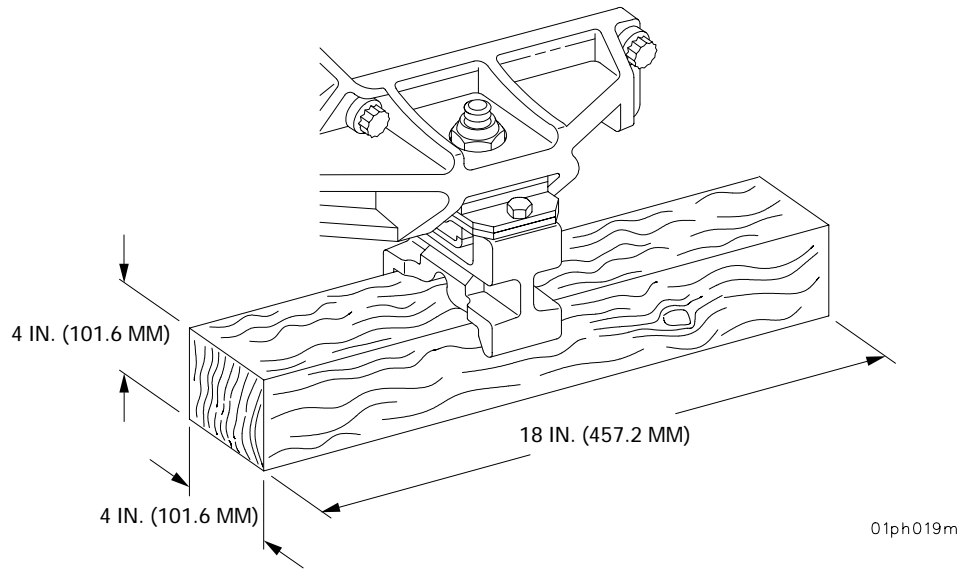

NOTE

All dimensions are shown in inches (millimeters).

Procedure:

Cut wood as shown.

MATERIALS	
DESCRIPTION	NSN/SPECIFICATION
WOOD, 4-IN. X 4-IN. X 18-IN.	MM-L-751

Figure 3. Stand, Powerpack

APPENDIX D TORQUE LIMITS

D-1 GENERAL.

This section provides general torque limits for screws used on the M109A6 vehicles. Special torque limits are indicated in the maintenance procedures for applicable components. The general torque limits given in this appendix shall be used when specific torque limits are not indicated in the maintenance procedure. These general torque limits cannot be applied to screws that retain rubber components. The rubber components will be damaged before the correct torque limit is reached. If a special torque limit is not given in the maintenance instructions, tighten the screw or nut until it touches the metal bracket, then tighten it one more turn.

D-2 TORQUE LIMITS.

Table D-1 lists dry torque limits. Dry torque limits are used on screws that do not have lubricants applied to the threads. Table D-2 lists wet torque limits. Wet torque limits are used on screws that have high-pressure lubricants applied to the threads.

D-3 HOW TO USE TORQUE TABLE.

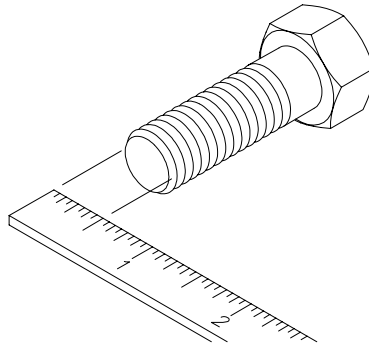

- a. Measure the diameter of the screw you are installing.

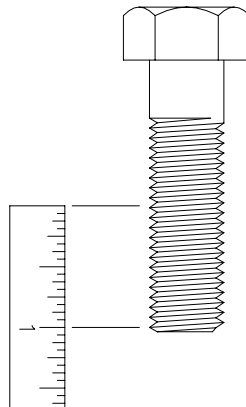

26ph008m

- b. Count the number of threads per inch or use a pitch gage.
- c. Under the heading **SIZE**, look down the left hand column until you find the diameter of the screw you are installing (there will usually be two lines beginning with the same size).
- d. In the second column under **SIZE**, find the number of threads per inch that matches the number of threads you counted in step b.

D-3 HOW TO USE TORQUE TABLE - CONTINUED

CAPSCREW HEAD MARKINGS
 Manufacturer's marks
 may vary. These are all SAE
 Grade 5 (3 line)

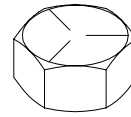
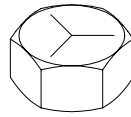
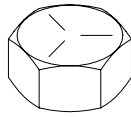

26ph007m

- e. To find the grade screw you are installing, match the markings on the head to the correct picture of CAPSCREW HEAD MARKINGS on the torque table.
- f. Look down the column under the picture you found in step e. until you find the torque limit in (lb-ft or N·m) for the diameter and threads per inch of the screw you are installing.

Table D-1. Torque Limits for Dry Fasteners

SAE CAPSCREW HEAD MARKINGS

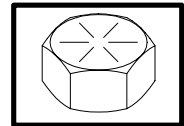
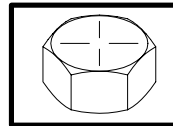
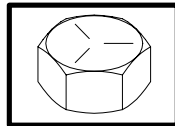
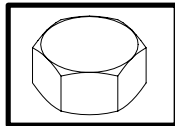

26ph006m

SIZE			TORQUE							
DIA. INS.	THREADS PER INCH	MMs	SAE GRADE No. 1 or 2		SAE GRADE No. 5		SAE GRADE No. 6 or 7		SAE GRADE No. 9	
			POUND- FEET	N·m	POUND- FEET	N·m	POUND- FEET	N·m	POUND- FEET	N·m
1/4	20	6.35	5	6.78	8.0	10.85	10	13.56	12.0	16.27
1/4	28	6.35	6	8.14	10.0	13.56	—	—	14.0	18.98
5/16	18	7.94	11	14.92	17.0	23.05	19	25.76	24.0	32.52
5/16	24	7.94	13	17.63	19.0	25.76	—	—	27.0	36.61
3/8	16	9.53	18	24.41	31.0	42.04	34	46.10	44.0	59.66
3/8	24	9.53	20	27.12	35.0	47.46	—	—	49.0	66.44
7/16	14	11.11	28	37.97	49.0	66.44	55	74.58	70.0	94.92
7/16	20	—	30	40.68	55.0	74.58	—	—	78.0	105.77
1/2	13	12.70	39	52.88	75.0	101.70	85	115.26	105.0	142.38
1/2	20	—	41	55.60	85.0	115.26	—	—	120.0	162.78
9/16	12	14.29	51	69.16	110.0	149.16	120	162.72	155.0	210.18
9/16	18	—	55	74.58	120.0	162.72	—	—	170.0	230.52
5/8	11	15.88	63	85.43	150.0	203.40	167	226.45	210.0	284.76
5/8	18	—	95	128.82	170.0	230.52	—	—	240.0	325.44
3/4	10	19.05	105	142.38	270.0	366.12	280	379.68	375.0	508.50
3/4	16	—	115	155.94	295.0	400.02	—	—	420.0	596.52
7/8	9	22.23	160	216.96	395.0	535.62	440	596.64	605.0	820.38
7/8	14	—	175	237.30	435.0	589.86	—	—	675.0	915.30
1	8	25.40	235	318.66	590.0	800.04	660	894.96	910.0	1233.96
1	14	—	250	339.00	660.0	894.96	—	—	990.0	1342.44
1-1/8	—	25.58	—	—	800.0	1064.8	—	—	1280.0	1735.7
					880.0	1193.3			1440.0	1952.8
1-1/4	—	31.75	—	—	—	—	—	—	1820.0	2467.9
									2000.0	2712.0
1-3/8	—	34.93	—	—	1460.0	1979.8	—	—	2380.0	3227.3
					1680.0	2278.1			2720.0	3688.3
1-1/2	—	38.10	—	—	1940.0	2630.6	—	—	3160.0	4285.0
					2200.0	2983.2			3560.0	4827.4

D-3 HOW TO USE TORQUE TABLE - CONTINUED

Table D-2. Torque Limits for Wet Fasteners

SAE CAPSCREW HEAD MARKINGS

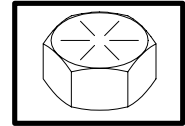
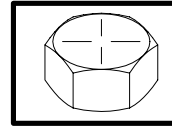
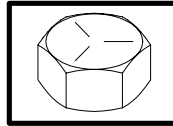
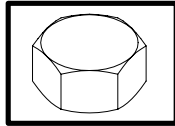

26ph006m

SIZE			TORQUE							
			SAE GRADE No. 1 or 2		SAE GRADE No. 5		SAE GRADE No. 6 or 7		SAE GRADE No. 8	
DIA. INS.	THREADS PER INCH	MMs	POUND-FEET	N-m	POUND-FEET	N-m	POUND-FEET	N-m	POUND-FEET	N-m
1/4	20	6.35	4.9	6.10	7.2	9.76	9.0	12.20	10.8	14.64
1/4	28	6.35	5.4	7.33	9.0	12.20	—	—	12.6	17.08
5/16	18	7.94	9.9	13.34	15.3	22.54	17.1	23.18	21.6	29.27
5/16	24	7.94	11.7	15.87	17.1	23.18	—	—	24.3	32.95
3/8	16	9.53	16.2	21.97	27.9	37.84	30.6	41.49	39.6	53.69
3/8	24	9.53	18.0	24.41	31.5	42.71	—	—	44.1	59.80
7/16	14	11.11	25.2	34.17	44.1	59.80	49.5	67.12	63.0	85.42
7/16	20	—	27.0	36.61	49.5	67.12	—	—	70.2	95.19
1/2	13	12.70	35.1	47.59	67.5	91.53	76.5	103.73	94.5	128.14
1/2	20	—	36.9	50.04	76.5	103.73	—	—	108.0	146.50
9/16	12	14.29	45.9	62.24	99.0	134.24	108.0	146.45	139.5	189.16
9/16	18	—	49.5	67.12	108.0	146.45	—	—	153.0	207.47
5/8	11	15.88	56.7	76.89	135.0	183.06	150.3	203.80	189.0	256.28
5/8	18	—	85.5	115.94	153.0	207.47	—	—	216.0	296.90
3/4	10	19.05	94.5	128.14	243.0	329.51	252.0	341.71	337.5	457.65
3/4	16	—	103.5	140.35	265.5	360.2	—	—	378.0	536.87
7/8	9	22.23	144.0	195.26	355.5	482.06	396.0	536.98	544.5	738.34
7/8	14	—	157.5	213.57	391.5	530.87	—	—	607.5	823.77
1	8	25.40	211.5	286.79	531.0	720.04	594.0	805.46	819.0	1110.56
1	14	—	225.0	305.10	594.0	805.46	—	—	891.0	1208.20
1-1/8	—	25.58	—	—	720.0	976.32	—	—	1152.0	1562.13
					792.0	1073.97			1296.0	1757.52
1-1/4	—	31.75	—	—	—	—	—	—	—	2221.11
										2440.80
1-3/8	—	34.93	—	—	1314.0	1781.82	—	—	2142.0	2904.57
					1512.0	2050.29			2448.0	3319.47
1-1/2	—	38.10	—	—	1746.0	2367.54	—	—	2844.0	3856.5
					1980.0	2684.88			3204.0	4344.66

D-4 TIGHTENING METAL FASTENERS.

When torquing a fastener, select a torque wrench whose range (Table D-3) fits the required torque value. A torque wrench is most accurate from 25% to 75% of its stated range. A torque wrench with a stated range of 0 to 100 will be most accurate from 25 to 75 Pound-Feet. The accuracy of readings will decrease as you approach 0 Pound-Feet or 100 Pound-Feet. The following ranges (Table D-3) are based on this principle.

D-4 TIGHTENING METAL FASTENERS - CONTINUED

Table D-3 TORQUE RANGES	
STATED RANGE	MOST EFFECTIVE RANGE
0-200 lb-in	4-13 lb-ft
0-600 lb-ft	50-450 lb-ft
0-170 lb-ft	44-131 lb-ft
15-75 lb-ft	30-60 lb-ft

D-5 FASTENER SIZE AND THREAD PATTERN.

Threaded fasteners are categorized according to diameter of the fastener shank. Thread styles are divided into broad groups, the two most common being coarse (Unified Coarse-UNC) and fine (Unified Fine-UNF). These groups are defined by the number of threads per inch on the bolt shanks. In addition, threads are categorized by thread class (Table D-4), which is a measure of the degree of fit between the threads of the bolt or screw (external threads) and the threads of the attaching nut or tapped hole (internal threads). The most common thread class for bolts and screws is Class 2.

Table D-4 THREAD CLASSES AND DESCRIPTION		
EXTERNAL	INTERNAL	FIT
1A	1B	LOOSE FIT
2A	2B	MEDIUM FIT
3A	3B	CLOSE FIT

Thread patterns are designed as follows:

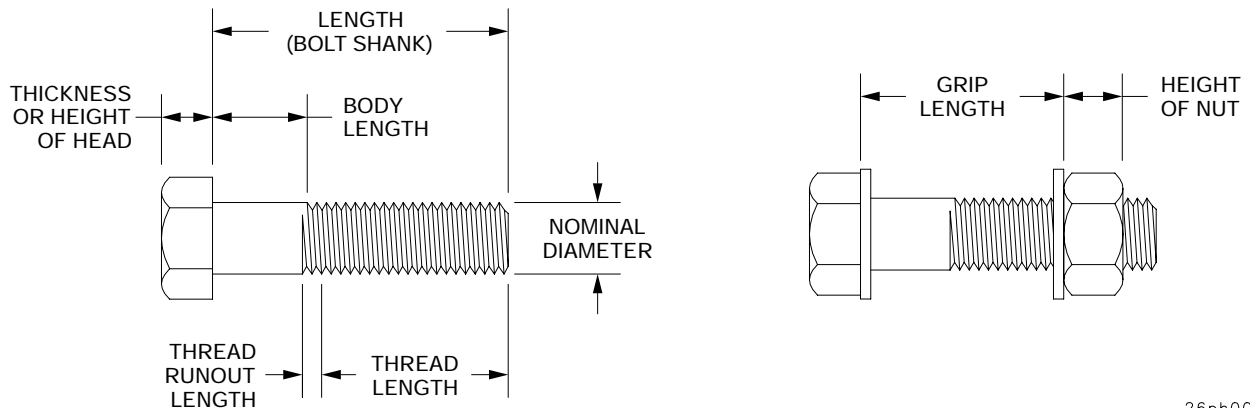
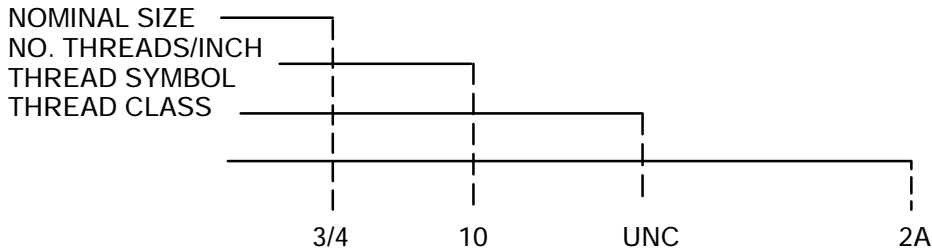

26ph005m

D-6 FASTENER GRADE.

In addition to being classified by thread type, threaded fasteners are also classified by material. The most familiar fastener classification system is the SAE grading system (Table D-5).

Table D-5 SAE Screw and Bolt Markings	
SCREWS	BOLTS
SAE GRADE 2 NO MARKING	SAE GRADE 6 4 RADIAL DASHES 90° APART
SAE GRADE 3 2 RADIAL DASHES 180° APART	SAE GRADE 7 5 RADIAL DASHES 72° APART
SAE GRADE 5 3 RADIAL DASHES 120° APART	SAE GRADE 8 6 RADIAL DASHES 60° APART

Markings On Hex Locknuts

GRADE A - No Marks

GRADE B - 3 Marks

GRADE C - 6 Marks

GRADE A - No Mark

GRADE B - Letter B

GRADE C - Letter C

GRADE A - No Notches

GRADE B - One Notch

GRADE C - Two Notches

APPENDIX E

MANDATORY REPLACEMENT PARTS LIST

Section I. INTRODUCTION

E-1 SCOPE.

This appendix is a cross-reference of item numbers to part numbers and is included for that purpose only.

E-2 EXPLANATION OF COLUMNS.

- a. Column (1) - Item Number. This number is assigned to the entry in the listing for cross-referencing to the part number.
- b. Column (2) - Part Number. Indicates the primary number used by the manufacturer (individual, company, firm, corporation, or Government activity), which controls the design and characteristics of the item by means of its engineering drawings, specification, standards, and inspection requirements to identify an item or range of items.
- c. Column (3) - Description. This column contains the nomenclature which appears on the first page of the task under the subheading "Materials/Parts".

Section II. MANDATORY REPLACEMENT PARTS LIST

(1) Item No.	(2) Part Number	(3) Description
1	10898034	Gasket
2	10898036	Gasket
3	10898038	Gasket
4	10930331	Gasket
5	10934405	Packing, Preformed
6	10952572-10	Pad, Cushioning
7	12260223	Kit, Ventilation
8	12268242	Seal, Plain
9	12289974	Gasket
10	12304190	Spacer
11	12361690-4	Gasket
12	12370812	Seal
13	21-2-5	Washer, Lock
14	30-01-1953-1212	Shielding, Gasket, Electronic
15	43W6335-40	Washer, Lock
16	475067	Gasket
17	488066	Screw, Assembled Washer
18	488558	Screw, Assembled Washer
19	488755	Rivet, Blind
20	488756	Nut, Plain, Assembled Washer
21	5 060115B	Sleeve, Compression, Tube-Hose Fitting
22	5162811	Cone, Vibration Dampener
23	5702941	Parts Kit, Track Adjuster
24	5703512	Parts Kit, Bilge Pump
25	57K0975	Kit, Repair, Fan Drive Assembly
26	57K0984	Transmission Trunnion Cap Replacement Kit
27	703349	Gasket
28	718768-22	Packing, Preformed
29	730051-1	Packing, Preformed
30	7718488	Gasket
31	7759648-1	Washer, Spring
32	7759648-2	Washer, Spring
33	7962191	Seal Assembly, Shaft, Spring Loaded
34	8712289-1	Nut, Self-Locking, Hexagon
35	8923791	Gasket
36	9166152	Washer, Lock
37	9419742	Screw, Assembled Washer
38	A52481-04	Gasket
39	DR55205	Washer, Lock
40	M83248/1-235	Packing, Preformed
41	MIL-C-5501/3R10	Cap, Dust, Protective
42	MS16562-193	Pin, Spring
43	MS16562-35	Pin, Spring
44	MS16624-1059	Snapping
45	MS16624-1075	Ring, Retaining

Section II. MANDATORY REPLACEMENT PARTS LIST

(1) Item No.	(2) Part Number	(3) Description
46	MS19070-052	Washer, Key
47	MS20470-AD5-6	Rivet
48	MS20995-C20	Lockwire
49	MS20995-C41	Lockwire
50	MS21042-5	Nut, Self-Locking
51	MS24630-34	Screw, Tapping
52	MS24665-229	Pin, Cotter
53	MS24665-629	Pin, Cotter
54	MS29513-038	Packing, Preformed
55	MS29513-154	Packing, Preformed
56	MS3367-1-9	Strap, Tiedown
57	MS3367-5-9	Strap, Tiedown, Electrical Components
58	MS35333-104	Washer, Lock
59	MS35333-106	Washer, Lock
60	MS35333-37	Washer, Lock
61	MS35333-38	Washer, Lock
62	MS35333-40	Washer, Lock
63	MS35335-30	Washer, Lock
64	MS35335-32	Washer, Lock
65	MS35335-33	Washer, Lock
66	MS35335-37	Washer, Lock
67	MS35338-100	Washer, Lock
68	MS35338-136	Washer, Lock
69	MS35338-39	Washer, Lock
70	MS35338-40	Washer, Lock
71	MS35338-41	Washer, Lock
72	MS35338-43	Washer, Lock
73	MS35338-44	Washer, Lock
74	MS35338-46	Washer, Lock
75	MS35338-47	Washer, Lock
76	MS35338-60	Washer, Lock
77	MS35338-61	Washer, Lock
78	MS35338-65	Washer, Lock
79	MS35338-66	Washer, Lock
80	MS35338-67	Washer, Lock
81	MS35338-69	Washer, Lock
82	MS35338-98	Washer, Lock
83	MS35489-42S	Grommet, Nonmettalic
84	MS35764-1291	Bolt, Self-Locking
85	MS51915-36-1	Seal, Plain Encased
86	MS5423/16-01	Seal
87	N012-01522	Parts Kit, Centrifugal Pump
88	MS35764-232	Bolt, Self-Locking

APPENDIX F TOOL IDENTIFICATION LIST

(1) ITEM NUMBER	(2) ITEM NAME	(3) NATIONAL STOCK NUMBER	(4) PART NUMBER	(5) REFERENCE
1	Adapter, screw driver	5130-00-240-5251	830-4	SC 4910-95-A31
2	Adapter, socket wrench, 1-in. M - 3/4-in. F	5120-00-227-8104	A-A-2172	TM 9-2350-314-24P1
3	Adapter, socket wrench, 3/4 M - 1/2 in. F	5120-00-144-5207	A-A-2172	SC 4910-95-A31
4	Adapter, socket wrench, 3/8 in. M - 1/2 in. F	5120-00-240-8702	B5-131	SC 4910-95-A31
5	Arbor press, hand operated	3444-00-449-7295	26A49	SC 4910-95-A31
6	Attachment, socket wrench, 3/8 dr - 5/16 in. hex bit	5120-00-683-8602	FA10B	SC 5180-95-B08
7	Bracket, fabricated, fan drive	-----	MI016	Appendix C
8	Brush, wire	7920-00-291-5815	8078883	SC 4910-95-A31
9	Caliper set micrometer (outside)	5210-00-554-7134	GGG-C-105	SC 4910-95-A63
10	Caliper, vernier	5210-00-293-2913	GGG-C-111	SC 3470-95-A31
11	Cap, vise jaw, brass	5120-00-221-1506	GGG-C-137SZ4	SC 4910-95-A31
12	Cylinder, graduated, laboratory	6640-00-092-6358	459462	TM 9-2350-314-24P1
13	Dial, indicating	5210-00-277-8840	196A	SC 3470-95-A02
14	Drain pan	4910-00-387-9592	450	SC 4910-95-A31
15	Drill, bit twist	5133-00-189-9324	10034	GSA Supply Catalog
15.1	Drill bit	5133-00-189-9326	GGG-D-751	SC 4910-95-A31
16	Drill, electric, portable	5130-00-807-9004	WD0061	SC 4910-95-A31
17	Drill set, twist	5133-00-293-0983	58	SC 4910-95-A31
18	Extension, 8 in., 3/4 in. dr	5120-00-243-7328	5661	SC 4910-95-A31
19	Fixture, bearing press	3020-01-374-0765	12370877	TM 9-2350-314-24P-1
20	Growler	6625-00-828-5810	TS965U	SC 4940-95-B20
21	Hammer	5120-00-903-8555	GGG-H-33	SC 4910-95-A62
22	Handle, ratchet, 3/4 in. dr	5120-00-249-1076	1940708	SC 4910-95-A31
23	Handle, socket wrench, 1-in. drive	5120-00-221-7988	A-A-2164	SC 4910-95-A31
24	Heater, gun type, electrical	4940-00-561-1002	500A	SC 4910-95-A31
25	Holder, screw driver bit	5120-00-065-8741	850	SC 4910-95-A31
26	Kit, terminal repair	5940-00-525-0907	213247	SC 4940-95-B20
27	Kit, probe	6625-01-102-6878	12303622	-----
28	Kit, purging	4931-00-065-1110	SC4931-95CLJ54	TM 9-2350-314-24P-1

APPENDIX F TOOL IDENTIFICATION LIST - CONTINUED

(1) ITEM NUMBER	(2) ITEM NAME	(3) NATIONAL STOCK NUMBER	(4) PART NUMBER	(5) REFERENCE
29	Pump, hand, vacuum	6640-01-446-9319	6130-0200	TM 9-2350-314-24P-1
30	Micrometer, depth	5210-00-542-4602	1JA1651H05	TM 9-2350-314-24P-1
31	Multimeter	6625-01-139-2512	T00377	SC 4910-95-A31
32	Pail, utility	7240-00-160-0455	AA-1273	TM 9-2350-314-10
33	Pliers, snapping	5120-00-789-0492	4440R	TM 9-2350-314-24P-1
34	Pliers, wire twisting	5120-00-542-4171	8491162	TM 9-2350-314-24P-1
35	Powerpack stand	-----	-----	Appendix C
36	Puller, common, mechanical	5120-00-595-9304	5630732	SC 4940-95-B20
37	Riveter, hand	5120-00-017-2849	250K	TM 9-2350-314-24P-1
38	Sander disc, electric	5130-00-596-9728	00S90	SC 3470-95-A08
39	Sling, engine lifting	4910-00-977-9398	10930560	TM 9-2350-314-24P-1
40	Sling, lifting, 8 ft	3940-00-675-5003	PD 101-96	TM 9-2350-314-24P-1
41	Sling, lifting	4910-00-473-7556	7081593	TM 9-2350-314-24P-1
42	Socket, 1-5/16 in., 3/4 in. dr	5120-00-232-5681	A-A-1394	SC 4910-95-A31
43	Socket, crowfoot	5120-00-222-7975	GGG-W-646	SC 4910-95-A31
44	Socket, wrench, face spanner, 1/2 in. dr	5120-00-034-8443	8390124	TM 9-2350-314-24P-1
45	Socket, wrench, face spanner, 1/2 in. dr	5120-01-255-8232	12268253	TM 9-2350-314-24P-1
46	Socket, socket wrench, 3-1/2 in., 1 in. dr	5130-00-076-8631	IM123	TM 9-2350-314-24P-1
47	Socket, socket wrench, 2-1/2 in., 1 in. dr	5120-00-189-7916	A-A-1392	SC 4910-95-A31
48	Socket, socket wrench, 1-3/4 in., 1 in. dr	5120-00-261-2837	A-A-1392	SC 4910-95-A31
49	Soldering gun	3439-00-542-0396	8200G3	SC 4910-95-A31
50	Threading set, screw	5180-00-422-4975	GGG-T-330	SC 4910-95-A31
50.1	Thread set	5180-00-448-2362	GGG-T-330	SC-4910-95-CL-A73
51	Tool kit, electrical contact	5180-00-876-9336	MIL-M-83521/6	SC 4940-95-B20
52	Tubing	4720-01-377-7404	12268571-1	TM 9-2350-314-24P-1
53	Vise, machinist, 4 in. jaws	5120-00-293-1439	504M2	SC 4910-95-A31
54	Welding shop, trailer-mounted	3431-01-090-1231	SC 3431-95-A04	TM 9-3431-265-14&P
55	Work stand, final drive	-----	MI015	Appendix C
56	Wrench set, spanner	5120-00-516-3863	MS8516-1	TM 9-2350-314-24P-1
57	Wrench, torque, 0-150 lb-ft, 1/2 in. dr	5120-00-247-2540	J1313	SC 4910-95-A31

APPENDIX F
TOOL IDENTIFICATION LIST - CONTINUED

(1) ITEM NUMBER	(2) ITEM NAME	(3) NATIONAL STOCK NUMBER	(4) PART NUMBER	(5) REFERENCE
58	Wrench, torque, 0-175 lb-ft, 1/2 in. dr	5120-00-640-6364	A-A-2411	SC 4910-95-A31
59	Wrench, torque, 0-600 lb-ft, 3/4 in. dr	5120-00-221-7983	A-A-2411	SC 4910-95-A31
60	Insulation	5970-00-854-6713	17-I-1728-401	TM 2350-314-24P-1

APPENDIX G

CORROSION PREVENTION AND CONTROL

G-1 SCOPE.

This appendix contains DS and GS level maintenance Corrosion Prevention and Control (CPC) information for various corrosion problems, treatments, tools, and available materials.

While corrosion is usually associated with rusting of metals, it can also include the deterioration of other materials such as rubber and plastic. Unusual cracking, softening, swelling, or breaking of these materials may be a corrosion problem.

It is important that any corrosion problem be reported. This will allow the problem to be corrected, and improvements made to prevent the problem on future items. Report identified corrosion problems on Standard Form 368, Quality Deficiency Report. Use of key words such as corrosion, rust, deteriorating, or cracking will assure that the information is identified as a CPC problem.

The form should be submitted to the address specified in DA PAM 738-750.

G-2 GENERAL.

The Corrosion Prevention and Control (CPC) program is a planned and organized effort to prevent damage to the M109A6 Howitzer during its operation. This is accomplished by the proper and timely identification, documentation, and implementation of corrective actions. As the first line of defense, the mechanic will visually check the vehicle for corrosion and identify methods of treatment.

G-3 TYPES OF CORROSION PROBLEMS.

a. Corrosion. Corrosion is the chemical disintegration of metals caused by reaction with other elements in the environment. Corrosion destroys the usefulness of the metal by producing compounds that do not possess the physical characteristics of the metal from which they were formed. Listed and described below are four stages of corrosion to be found in metals.

(1) Stage I corrosion. Discoloration or staining. This stage of corrosion appears as a thin gray, black, or reddish film on ferrous metals; as a white or gray film on aluminum, magnesium, zinc, and their alloys; and in varied colors (green, blue-green, brown, or black) on copper and copper alloys. This is the initial stage of corrosion; it does not extend beyond the surface of the metals, and it is easily removed.

(2) Stage II corrosion. Etching. When rust or corrosion is removed, the surface of the metal is slightly roughened, but holes in the surface are not identifiable.

(3) Stage III corrosion. Pitting. In this type of corrosion, holes in the surface of the metal are visible after the corrosive coating is removed from the metal.

(4) Stage IV corrosion. Scales, pitting, and powdering. Corrosion in this stage has progressed to the point where fit, wear, function, or life of the part has been affected. Powdery or scaly conditions accompanied by deep pitting and/or irregular flaking of metal is encountered in this stage of corrosion.

b. Corrosion of Painted Surfaces. This type of corrosion occurs primarily on painted steel surfaces. The paint is often cracked and the area may have a reddish brown appearance. The size and location may vary from small spots to large areas. It may occur at mating parts such as where the suspension mates to the hull or around fasteners such as nuts, bolts, or washers.

c. Corrosion of Unpainted Moving Parts. This type of corrosion occurs on moving parts such as hinges, pins, and catches where the original protective finish was removed through use or exposure to weather. It also has a reddish brown appearance.

d. Stress Corrosion Cracks. Stress corrosion cracking is a form of corrosion that can occur in high strength steel and aluminum. It is found in the form of cracks or seams in areas where no parts are joined.

e. Selective Leaching. This type of corrosion occurs on brass or bronze components found primarily in electrical connectors. This has a spongy type appearance with much of the original metal removed.

G-4 TREATMENT PROCEDURES.

WARNING

Dry-cleaning solvent (P-D-680), used to clean parts, is toxic and flammable. Wear protective goggles and gloves and use only in a well-ventilated area. Avoid contact with skin, eyes, and clothes. Do not breathe vapors. Do not use near open flame or excessive heat. Do not smoke when using solvent. Failure to do so could cause SERIOUS INJURY. If you become dizzy while using dry-cleaning solvent, get fresh air immediately, and if necessary, get medical attention. If contact with skin or clothes is made, flush thoroughly with water. If the solvent contacts your eyes, wash them with water immediately and obtain medical aid (ref. FM 21-11).

- a. General. Keep the vehicle and its individual components clean. Dirt, grease, oil, and debris may conceal a serious problem. Clean components as needed. Use dry-cleaning solvent (item 29, Appx B) on all metal surfaces. Use mild soap (item 9, Appx B) and water to clean rubber and plastic parts.

Remove existing (old) lubricant with dry-cleaning solvent (item 29, Appx B) or cleaner if possible. Corrosion or corrosion products should be carefully removed with a soft bristle brush or abrasive cloth (item 7, Appx B). Do not use stainless steel brush, steel wool or sand paper. Use care not to remove paint or protective finishes from other non-corroded parts. Thoroughly clean with solvent or cleaner.

Lubricate equipment in accordance with TM 9-2350-314-10.

Clean batteries in accordance with TM 9-6140-200-14.

- b. Painted Surfaces. Refer to TM 43-0139 and TB 43-0147 for information on painting.
- c. Unpainted Surfaces. Coat unpainted metal surfaces with oil or grease as appropriate.
- d. Stress Corrosion Cracks. The crack should be verified by probing into the metal, and not just checking cracked paint. If cracked, weld in accordance with aluminum welding MIL-STD-372 or steel welding MIL-STD-1943.
- e. Rubber and Plastic Materials. The only repair to deteriorating rubber or plastic is to replace at Unit Maintenance or a higher level of maintenance (if required).
- f. Electrical parts. Solvents such as dry-cleaning solvent should not be used to clean electrical insulation, wires, cables, or wiring harnesses because of the damage effects of solvents on materials such as fibers and rubber. To clean these items, wipe clean with a damp cloth (item 21, Appx B) and immediately dry with a clean dry cloth (item 21, Appx B). Clean contact points with fine abrasive paper (item 19, Appx B) and dust thoroughly after cleaning. If selective leaching or cracking is present on connectors, replace connectors at Unit Maintenance or a higher level of maintenance (if required).

G-5 TOOLS AND MATERIALS.

The tools and materials used by the mechanic in performing CPC on the M109A6 Howitzer are listed in Appendix B (Expendable and Durable Items List) and Appendix F (Tool Identification List).

ALPHABETICAL INDEX

A

- Accessory Control Box, 7-24, 7-40
- Air Cleaner Blower Assembly, 5-2
- Assemblies and Mount, Cooling Fan, 6-24

B

- Ball and Roller Bearings, 2-3
- Bilge Pump, 11-2
- Blower Motor Assembly, 12-19
- Body, Cab, Hood, and Hull Assemblies, 10-2

C

- Cleaning, Painting, and Lubrication, 2-6
- Common Tools and Equipment, 2-2
- Cooling Fan Assemblies and Mount, 6-24
- Cooling Fan Drive Assembly, 6-6
- Cooling System, 6-1
- Corrosion Prevention and Control, 1-3, G-1

D

- Destruction of Army Materiel to Prevent Enemy Use, 1-2
- Differences Between Models, 1-4
- Disassembly and Assembly Procedures, 2-2
- Driver's Hatch and Periscopes, 10-11
- Driver's Hatch Housing Assembly, 10-11

E

- Electrical Systems, 7-1
- Electrical Test Equipment and Electrical Testing, 2-6
- Enclosure Assembly —Crew Compartment Warning Light, 7-20
- Engine Assembly, 4-13

Engine Compartment Bulkhead Insulation and Shields, 10-2

Engine Coolant Heater Assembly, 12-22

Engine Coolant Heater Assembly Test and Adjustment, 12-33

Engine Cooling Fan Assemblies and Mount, 6-24

Equipment Characteristics, Capabilities and Features, 1-4

Equipment Data, 1-4

Equipment Description and Data, 1-4

Equipment Operation and Description, 1-4

Expendable and Durable Items List, B-1

F

Fan Cooling Assemblies and Mount, 6-24

Field Manuals, A-1

Final Drive Assembly, 4-25

Forms, A-1

Fuel System, 5-1

Fuel Tank Mounting Plate and Retaining Band, 5-26

Fuel Tank Pads and Hull-Mounted Pads, 5-24

Fuel Tanks, 5-9

G

Gear Box Assembly Breather and Seal, 6-4

General Hull Maintenance Instructions, 2-2

General Information, 1-2

Destruction of Army Materiel to Prevent Enemy Use, 1-2

Maintenance Forms, Records and Reports, 1-2

Nomenclature Cross-Reference List, 1-3

Preparation for Storage or Shipment, 1-3

Quality Assurance (QA), 1-3

Scope, 1-2

General Maintenance, 2-1

General Troubleshooting Instructions, 3-2

Generator Pulley Assembly, 7-2

ALPHABETICAL INDEX - CONTINUED

Gun Tube Travel Lock Control Box Assembly, 7-6

H

Heater Control Box and Bracket, 12-37

How to Use this Manual, iii

Hull Wiring Harness, 7-41

■ Hull Rear Door, 10-12

I

Illustrated List of Manufactured Items, C-1

Instrument or Engine Control Panels, 7-6

Introduction, 1-1

L

Location and Description of Major Components, 1-4

M

Maintenance Forms, Records and Reports, 1-2

Mandatory Replacement Parts List, E-1

Mass Ring and Flexible Coupling, 4-15

Military Specifications, A-3

Miscellaneous Publications, A-3

Mount, Cooling Fan Assemblies, 6-24

N

Nomenclature Cross-Reference List, 1-3

P

Personnel Ventilating Air Duct Fan, 7-56

Preparation for Storage or Shipment, 1-3, 4-17

Principles of Operation, 1-4

Q

Quality Assurance (QA), 1-3

Quick Guide To Troubleshooting, 3-2

R

Race Ring Locating Pin, 10-10

References, A-1

Regulations, A-3

Remote Lever (Steering), 9-2

Removal and Installation of Engine and
Transmission-Related Components, 4-2

Removing Burrs, Scratches, and Raised Metal, 2-4

Repair Parts, 2-2

Repair Parts, Special Tools, TMDE, and Support
Equipment, 2-2

General, 2-2

Replacement of Parts, 2-3

Reporting Equipment Improvement
Recommendations, 1-3

S

Screw Thread Inserts (One Piece Type), 2-4

Separation of Engine from Power Train Assembly,
4-7

Shafts, Gears, and Bearings, 2-6

Shipping and Storage Containers, Engine Parts, and
Accessories List, 4-17

Special Tools and Support Equipment, 2-2

Steering, 9-1

Suspension Assembly, 8-2

T

Tanks, Lines, Fittings, and Headers, 5-9

Technical Bulletins, A-1

Technical Manuals, A-1

Tool Identification List, F-1

ALPHABETICAL INDEX

Torque Limits, D-1
Torsion Bar Anchor and Cover Plate, Position Three,
8-2
Towing Eye Replacement, 13-2
Track Adjuster Cylinder Assembly, 8-4
Track Idlers and Brackets, 8-4
Transmission Trunnion Caps, 4-21
Transmission Trunnion Replacement Caps, 4-21
Troubleshooting, 3-1
Troubleshooting Procedures, 3-5

V

Vaneaxial Cooling Fan Assembly, 6-2
Ventilating Equipment, 7-56
Ventilation Kit, 12-41
Vibration Dampener and Adapter, 4-13
Voltage Regulator Control Box Assembly, 7-13

W

Warranty Information, 1-3
Welding, 2-6
Wheels and Tracks, 8-1
Winterization Kit Components, 12-19
Winterization Kit Installation, 12-2
Wiring Harness and Cable Repair, 7-41

By Order of the Secretary of the Army:

DENNIS J. REIMER
General, United States Army
Chief of Staff

JOEL B. HUDSON
Acting Administrative Assistant to the
Secretary of the Army
05387

DISTRIBUTION: To be distributed in accordance with DA Form 12-37-E, block 1935 requirements for TM 9-2350-314-34-1.

SOMETHING WRONG

WITH THIS PUBLICATION?



THEN...JOT DOWN THE DOPE ABOUT IT ON THIS FORM, CAREFULLY TEAR IT OUT, FOLD IT AND DROP IT IN THE MAIL.

FROM: (PRINT YOUR UNIT'S COMPLETE ADDRESS)

From Your Unit

DATE SENT

PUBLICATION NUMBER

TM 9-2350-314-34-1

PUBLICATION DATE

FEBRUARY, 1999

PUBLICATION TITLE

DIRECT SUPPORT AND GENERAL SUPPORT MAINTENANCE MANUAL FOR 155MM M109A6, SP HOWITZER

BE EXACT. . .PIN-POINT WHERE IT IS

PAGE NO

7-3

PARA-GRAPH

7-1

FIGURE NO

TABLE NO

IN THIS SPACE TELL WHAT IS WRONG AND WHAT SHOULD BE DONE ABOUT IT:

Torque value of 250-350 lb-ft (28-39 N•m) in step 7(a) should be 250-350 lb-in (28-39 N•m)

SAMPLE

TEAR ALONG PERFORATED LINE

PRINTED NAME GRADE OR TITLE AND TELEPHONE NUMBER

Your name, your title, your phone number

SIGN HERE

Your signature

SOMETHING WRONG

WITH THIS PUBLICATION?



THEN...JOT DOWN THE DOPE ABOUT IT ON THIS FORM, CAREFULLY TEAR IT OUT, FOLD IT AND DROP IT IN THE MAIL.

FROM: (PRINT YOUR UNIT'S COMPLETE ADDRESS)

DATE SENT

PUBLICATION NUMBER

TM 9-2350-314-34-1

PUBLICATION DATE

FEBRUARY, 1999

PUBLICATION TITLE

DIRECT SUPPORT AND GENERAL SUPPORT MAINTENANCE MANUAL FOR 155MM M109A6, SP HOWITZER

BE EXACT. . .PIN-POINT WHERE IT IS

PAGE NO

PARA-GRAPH

FIGURE NO

TABLE NO

IN THIS SPACE TELL WHAT IS WRONG AND WHAT SHOULD BE DONE ABOUT IT:

TEAR ALONG PERFORATED LINE

PRINTED NAME GRADE OR TITLE AND TELEPHONE NUMBER

SIGN HERE

FILL IN YOUR
UNIT'S ADDRESS



FOLD BACK

DEPARTMENT OF THE ARMY



OFFICIAL BUSINESS

NO POSTAGE
NECESSARY
IF MAILED
IN THE
UNITED STATES

BUSINESS REPLY MAIL
FIRST CLASS BRM PERMIT NO. 82 ROCK ISLAND, IL

POSTAGE WILL BE PAID BY ROCK ISLAND ARSENAL

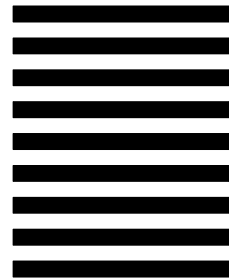

Technical Publication Information Office
TACOM-RI
1 Rock Island Arsenal
Rock Island, IL 61299-7630

TEAR ALONG PERFORATED LINE



NOTES:

- ① ELECTRICAL PATH PROVIDED VIA BOLTING GND BUS TO CURRENT SHUNT.
- ② TRAVEL LOCK ACTUATOR SWITCHES SHOWN WITH GUN TUBE IN STOWED POSITION.
- ③ VEHICLE TEST METER (STE/ICE) CONNECTION.
- ④ HEADLIGHT CIRCUIT LEGEND:
 18 - LOW BEAM SERVICE
 17 - HIGH BEAM SERVICE
 19 - B O DRIVER
 20 - B O MARKER
 91 - GND
 514 - B O HIGH BEAM (L.R.)
 515 - B O LOW BEAM (L.R.)
- ⑤ REFER TO TM9-2815-202-34.

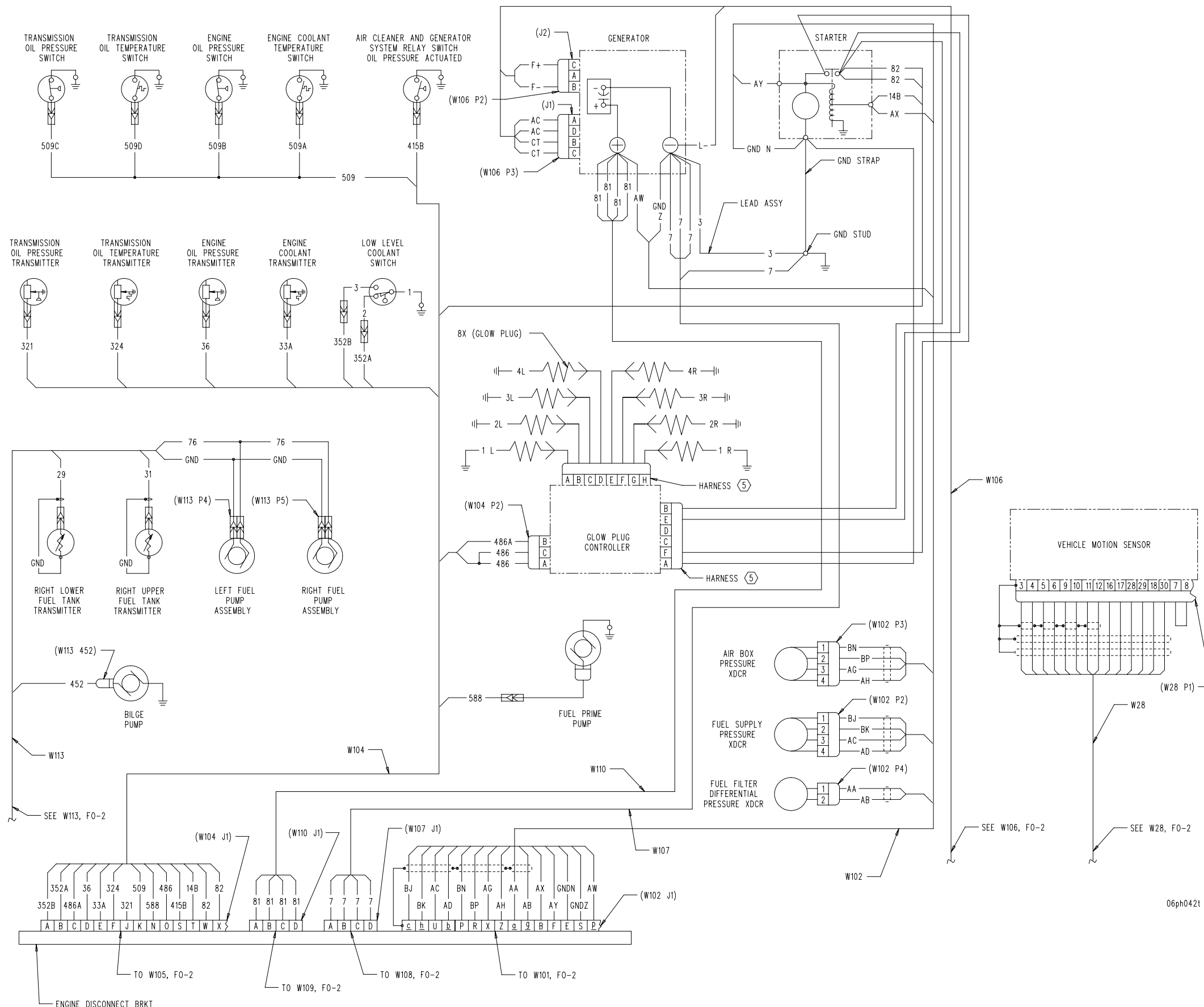

06ph042t

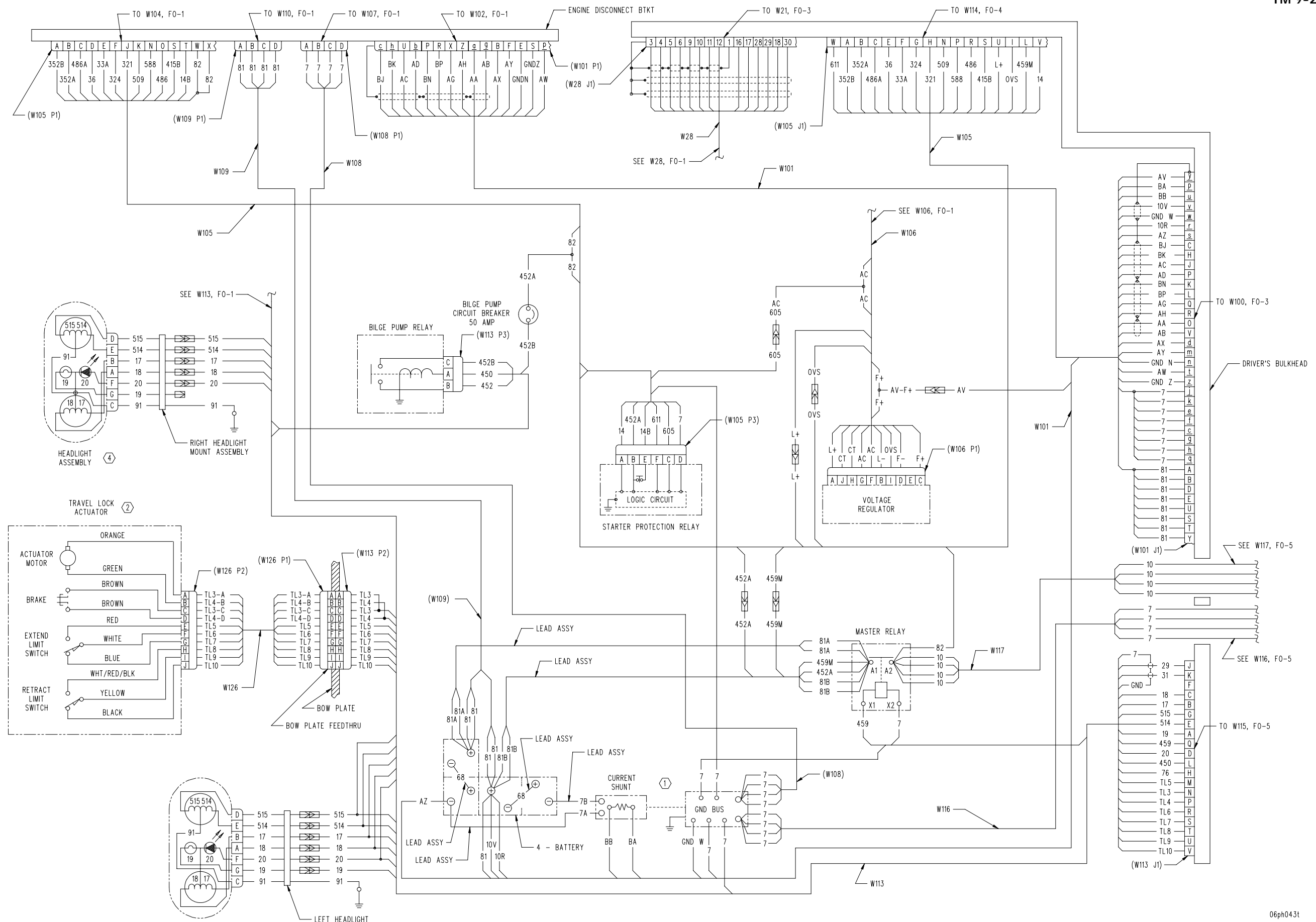

FO-2. HULL ELECTRICAL SCHEMATIC (SHEET 2 OF 6)

06ph043t

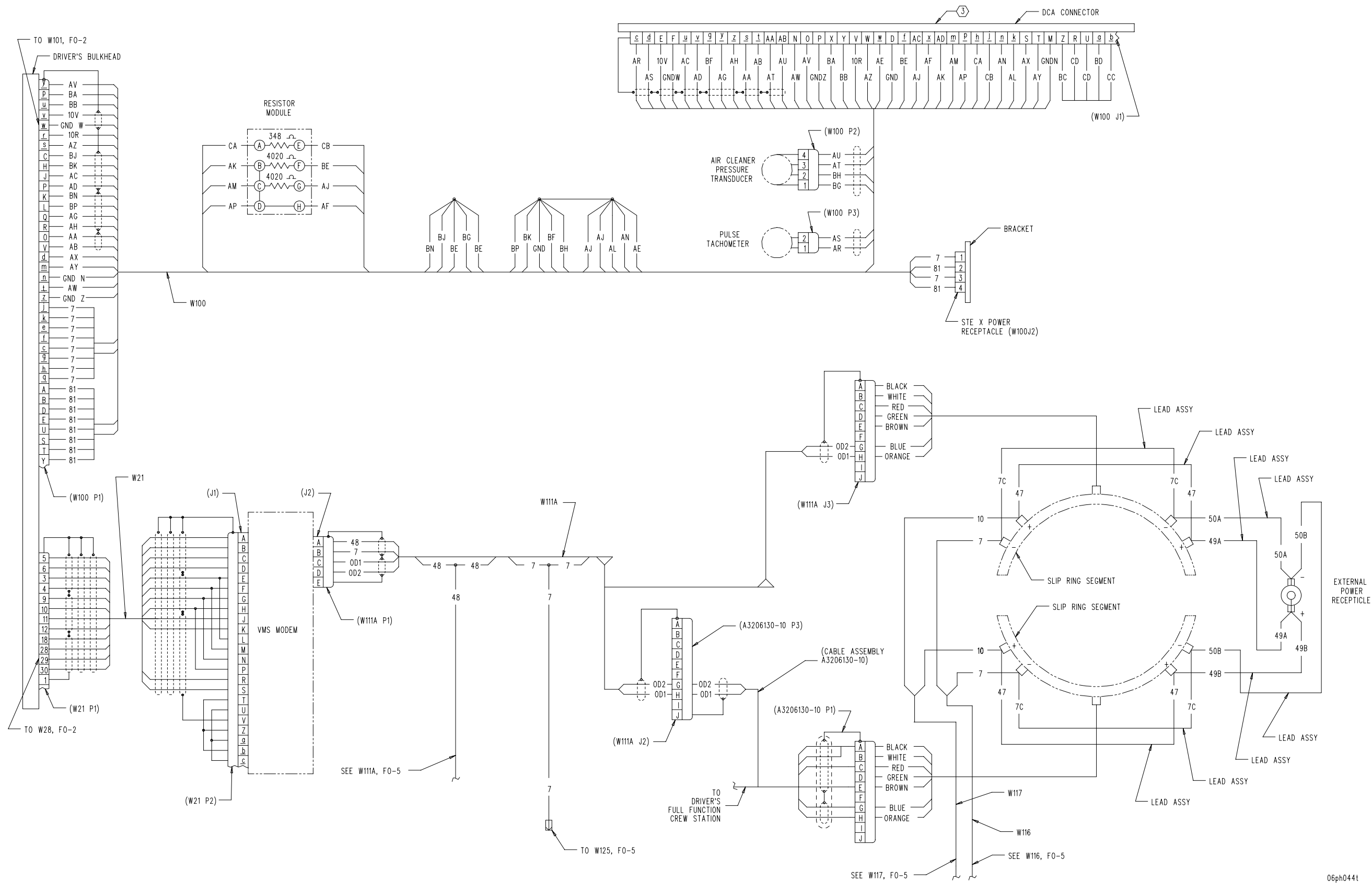

06ph044t

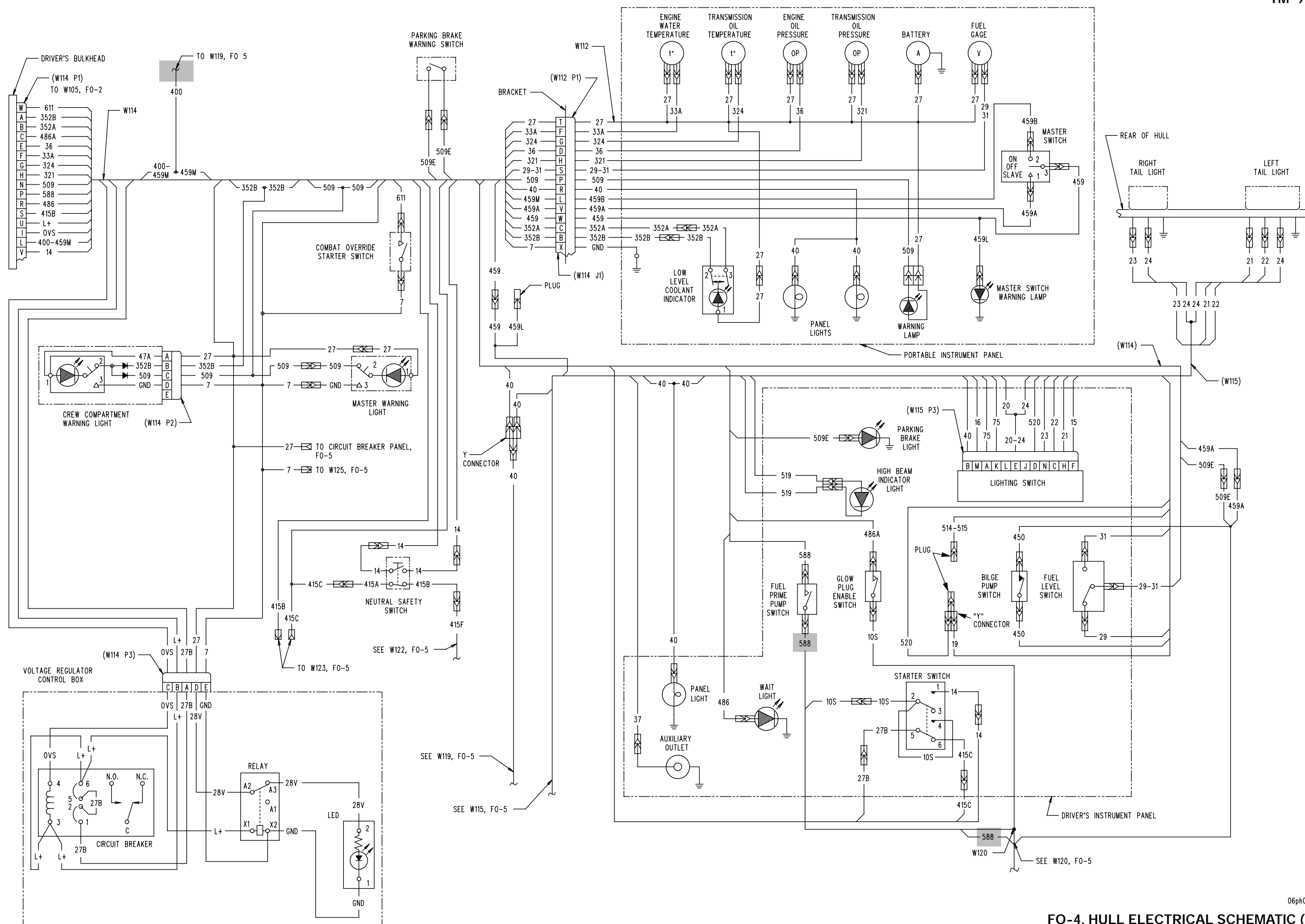

FO-4. HULL ELECTRICAL SCHEMATIC (SHEET 4 OF 6)

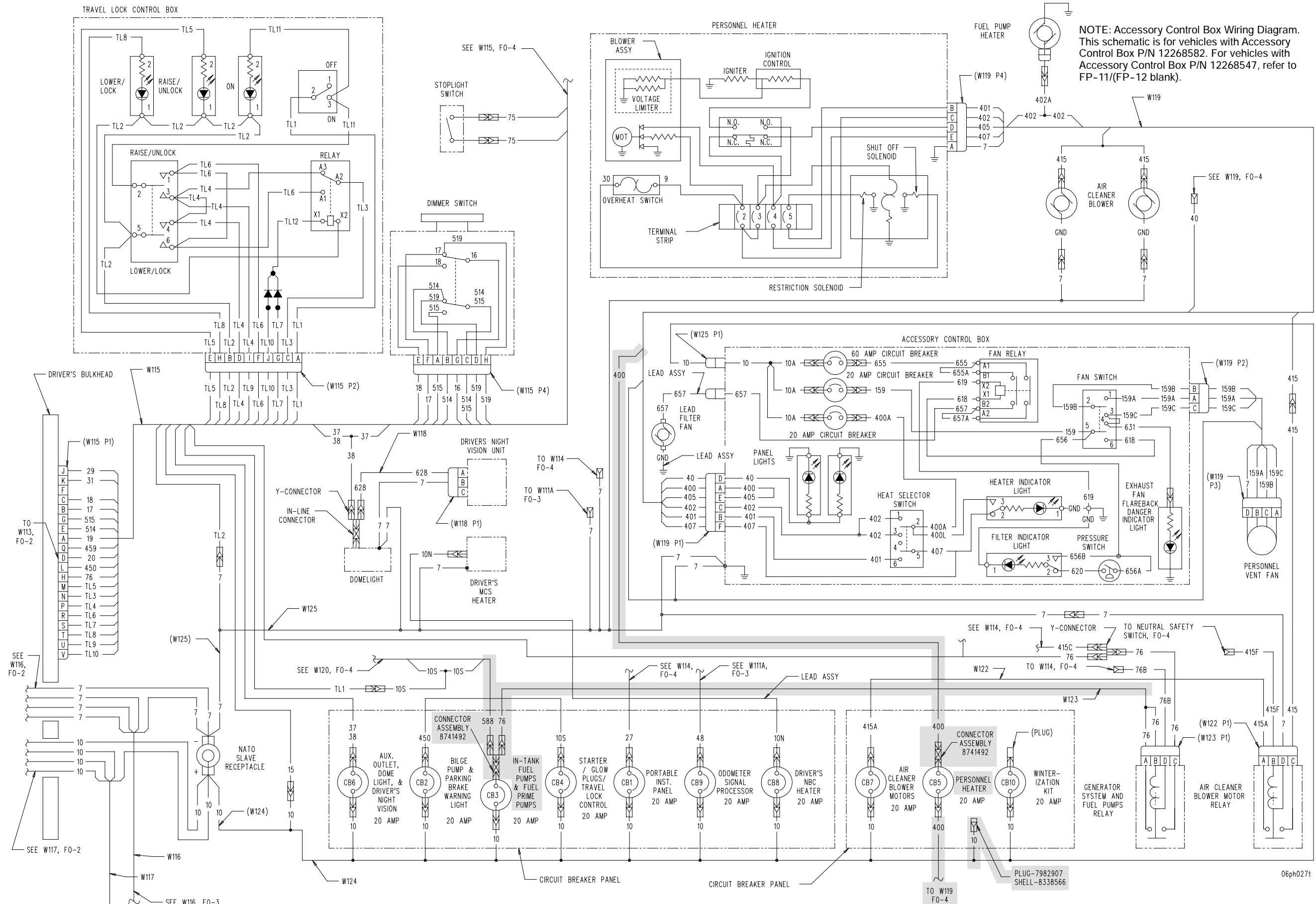

NOTE: Accessory Control Box Wiring Diagram. This schematic is for vehicles with Accessory Control Box P/N 12268582. For vehicles with Accessory Control Box P/N 12268547, refer to FP-11/(FP-12 blank).

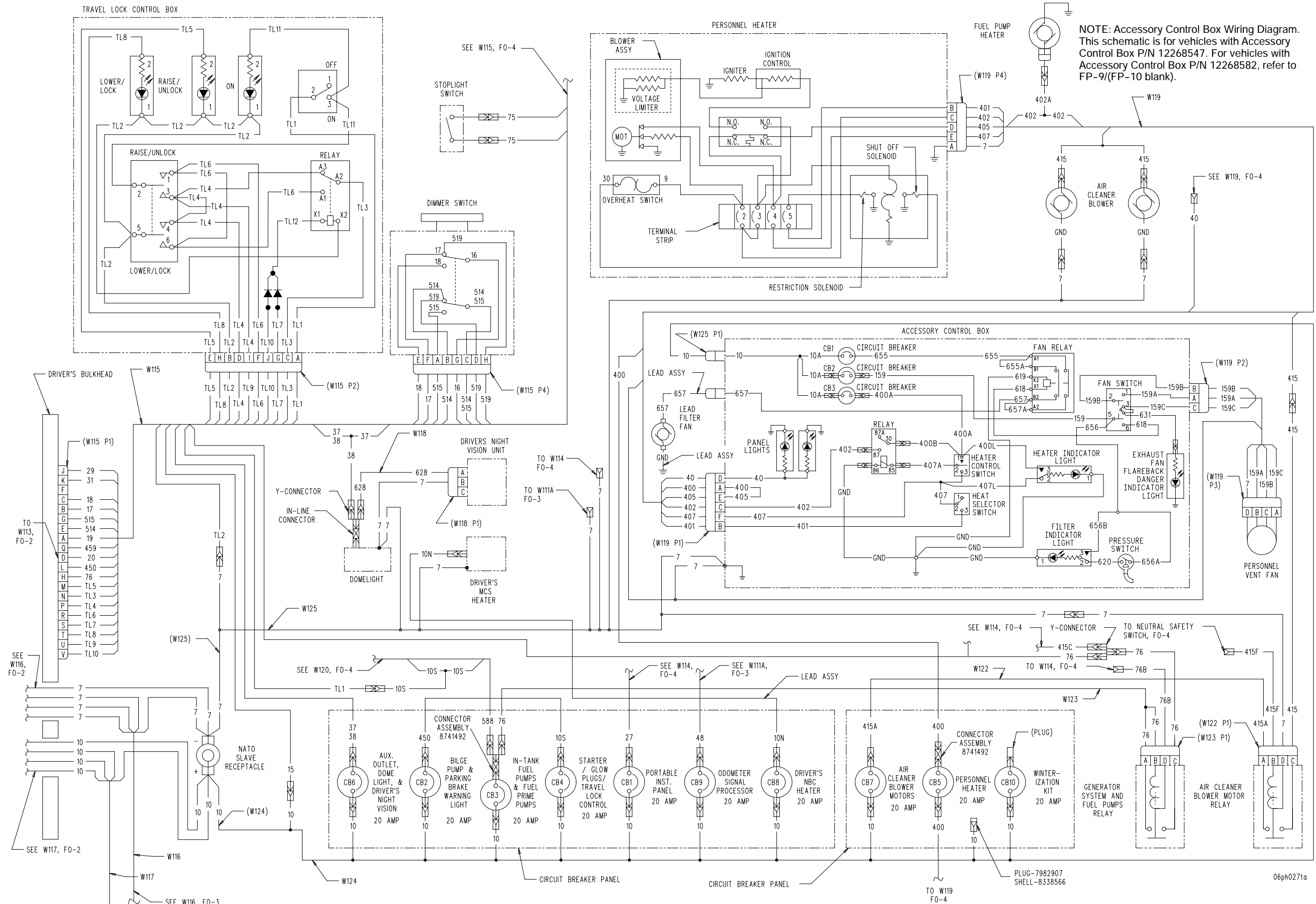

NOTE: Accessory Control Box Wiring Diagram. This schematic is for vehicles with Accessory Control Box P/N 12268547. For vehicles with Accessory Control Box P/N 12268582, refer to FP-9/(FP-10 blank).

CONVERSION TABLE

inch	decimal	mm
1/64	0.015625	0.3969
1/32	0.031250	0.7938
3/64	0.046875	1.1906
1/16	0.062500	1.5875
5/64	0.078125	1.9844
3/32	0.093750	2.3812
7/64	0.109375	2.7781
1/8	0.125000	3.1750
9/64	0.140625	3.5719
5/32	0.156250	3.9688
11/64	0.171875	4.3656
3/16	0.187500	4.7625
13/64	0.203125	5.1594
7/32	0.218750	5.5562
15/64	0.234375	5.9531
1/4	0.250000	6.3500
17/64	0.265625	6.7469
9/32	0.281250	7.1438
19/64	0.296875	7.5406
5/16	0.312500	7.9375
21/64	0.328125	8.3344
11/32	0.343750	8.7312

inch	decimal	mm
23/64	0.359375	9.1281
3/8	0.375000	9.5250
25/64	0.390625	9.9219
13/32	0.406250	10.3188
27/64	0.421875	10.7156
7/16	0.437500	11.1125
29/64	0.453125	11.5094
15/32	0.468750	11.9062
31/64	0.484375	12.3031
1/2	0.500000	12.7000
33/64	0.515625	13.0969
17/32	0.531250	13.4938
35/64	0.546875	13.8906
9/16	0.562500	14.2875
37/64	0.578125	14.6844
19/32	0.593750	15.0812
39/64	0.609375	15.4781
5/8	0.625000	15.8750
41/64	0.640625	16.2719
21/32	0.656250	16.6688
43/64	0.671875	17.0656
11/16	0.687500	17.4625

inch	decimal	mm
45/64	0.703125	17.8594
23/32	0.718750	18.2562
47/64	0.734375	18.6531
3/4	0.750000	19.0500
49/64	0.765625	19.4469
25/32	0.781250	19.8437
51/64	0.796875	20.2406
13/16	0.812500	20.6375
53/64	0.828125	21.0344
27/32	0.843750	21.4312
55/64	0.859375	21.8281
7/8	0.875000	22.2250
57/64	0.890625	22.6219
29/32	0.906250	23.0188
59/64	0.921875	23.4156
15/16	0.937500	23.8125
61/64	0.953125	24.2094
31/32	0.967500	24.6062
63/64	0.984375	25.0031
1	1.000000	25.4000

THE METRIC SYSTEM AND EQUIVALENTS

LINEAR MEASURE

1 Centimeter = 10 Millimeters = 0.01 Meters = 0.3937 Inches
 1 Meter = 100 Centimeters = 1000 Millimeters = 39.37 Inches
 1 Kilometer = 1000 Meters = 0.621 Miles

WEIGHTS

1 Gram = 0.001 Kilograms = 1000 Milligrams = 0.035 Ounces
 1 Kilogram = 1000 Grams = 2.2 Lb.
 1 Metric Ton = 1000 Kilograms = 1 Megagram = 1.1 Short Tons

LIQUID MEASURE

1 Milliliter = 0.001 Liters = 0.0338 Fluid Ounces
 1 Liter = 1000 Milliliters = 33.82 Fluid Ounces

SQUARE MEASURE

1 Sq. Centimeter = 100 Sq. Millimeters = 0.155 Sq. Inches
 1 Sq. Meter = 10,000 Sq. Centimeters = 10.76 Sq. Feet
 1 Sq. Kilometer = 1,000 Sq. Meters = 0.386 Sq. Miles

CUBIC MEASURE

1 Cu. Centimeter = 1000 Cu. Millimeters = 0.06 Cu. Inches
 1 Cu. Meter = 1,000,000 Cu. Centimeters = 35.31 Cu. Feet

TEMPERATURE

$^{\circ}\text{C} = 5/9 (^{\circ}\text{F} - 32)$
 212 $^{\circ}$ Fahrenheit is equivalent to 100 $^{\circ}$ Celsius
 90 $^{\circ}$ Fahrenheit is equivalent to 32.2 $^{\circ}$ Celsius
 32 $^{\circ}$ Fahrenheit is equivalent to 0 $^{\circ}$ Celsius
 $(9/5 \times ^{\circ}\text{C}) + 32 = ^{\circ}\text{F}$

APPROXIMATE CONVERSION FACTORS

TO CHANGE	TO	MULTIPLY BY
Inches	Centimeters	2.540
Feet	Meters	0.305
Yards	Meters	0.914
Miles	Kilometers	1.609
Square Inches	Square Centimeters	6.451
Square Feet	Square Meters	0.093
Square Yards	Square Meters	0.836
Square Miles	Square Kilometers	2.590
Acres	Square Hectometers	0.405
Cubic Feet	Cubic Meters	0.028
Cubic Yards	Cubic Meters	0.765
Fluid Ounces	Millimeters	29.573
Pints	Liters	0.473
Quarts	Liters	0.946
Gallons	Liters	3.785
Ounces	Grams	28.349
Pounds	Kilograms	0.454
Short Tons	Metric Tons	0.907
Pound-Feet	Newton-Meters	1.356
Pounds per Square Inch	Kilopascals	6.895
Miles per Gallon	Kilometers per Liter	0.425
Miles per Hour	Kilometers per Hour	1.609

TO CHANGE	TO	MULTIPLY BY
Centimeters	Inches	0.394
Meters	Feet	3.280
Meters	Yards	1.094
Kilometers	Miles	0.621
Square Centimeters	Square Inches	0.155
Square Meters	Square Feet	10.764
Square Meters	Square Yards	1.196
Square Kilometers	Square Miles	0.386
Square Hectometers	Acres	2.471
Cubic Meters	Cubic Feet	35.315
Cubic Meters	Cubic Yards	1.308
Milliliters	Fluid Ounces	0.034
Liters	Pints	2.113
Liters	Quarts	1.057
Liters	Gallons	0.264
Grams	Ounces	0.035
Kilograms	Pounds	2.205
Metric Tons	Short Tons	1.102
Newton-Meters	Pound-Feet	0.738
Kilopascals	Pounds per Square Inch	0.145
Kilometers per Liter	Miles per Gallon	2.354
Kilometers per Hour	Miles per Hour	0.621

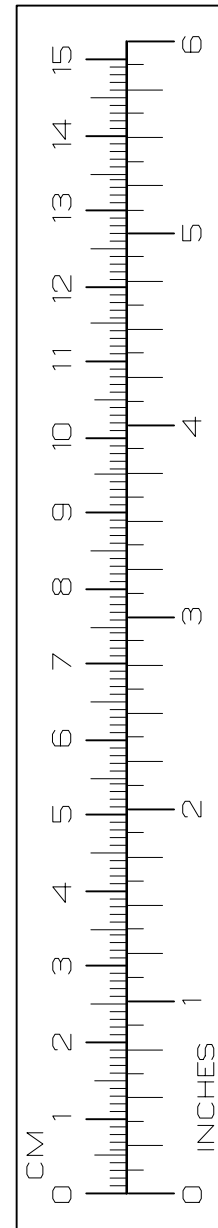

PIN: 071829